



COWELL® Implant Solution

Help your daily practice superior

Ver.32



대한민국 임플란트의 시작
코웰메디 임플란트



SINCE
1994

국산 임플란트 사용

대한민국 최고(最古) 임플란트 임상 증례

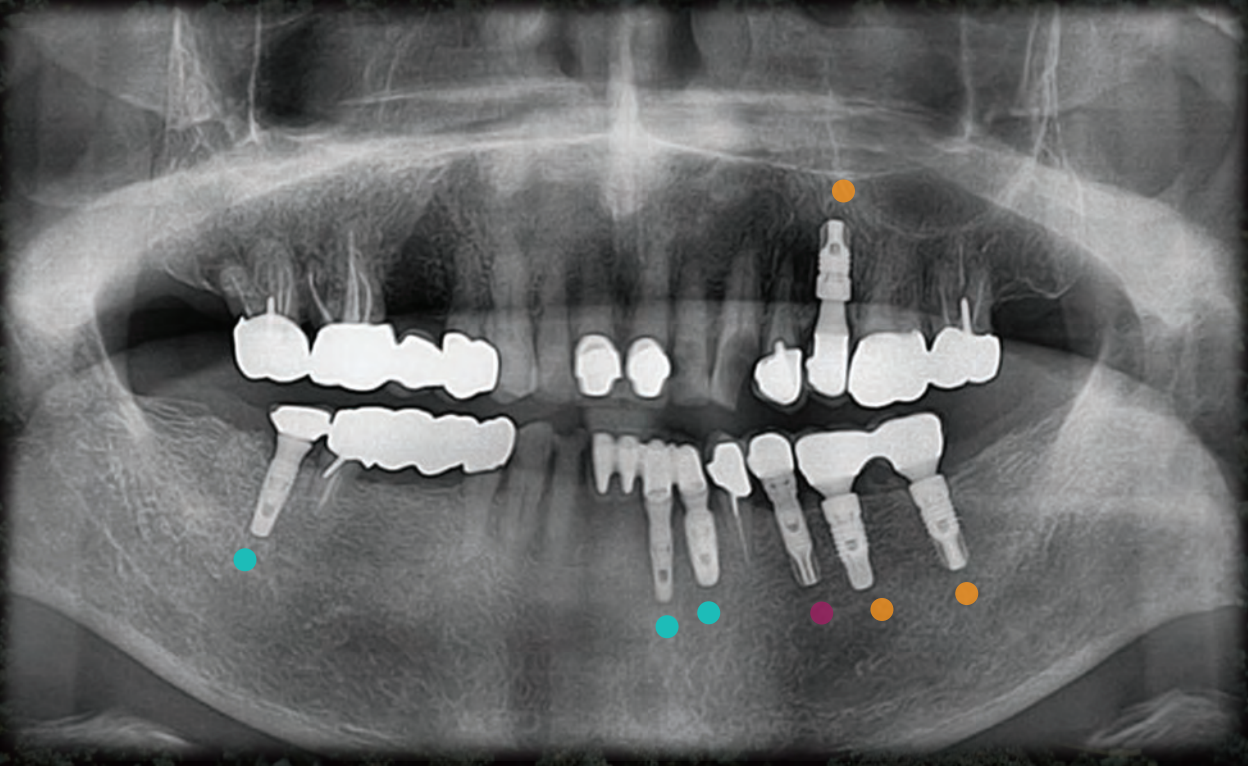

Bioplant



Atlas

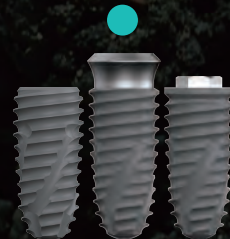

INNO

#35: BIOPLANT, 1994년 개발된 대한민국 최초의 국산 임플란트

#25, 36 & 37: ATLAS, 국내 최초로 ASD 표면이 적용된 임플란트

#32, 33 & 47: INNO, SLA-SH 표면이 적용된 5세대 임플란트

Contents

COWELLMEDI History	004
--------------------	-----

REID (Research & Education in Implant Dentistry)	006
--	-----



COWELL Implant System

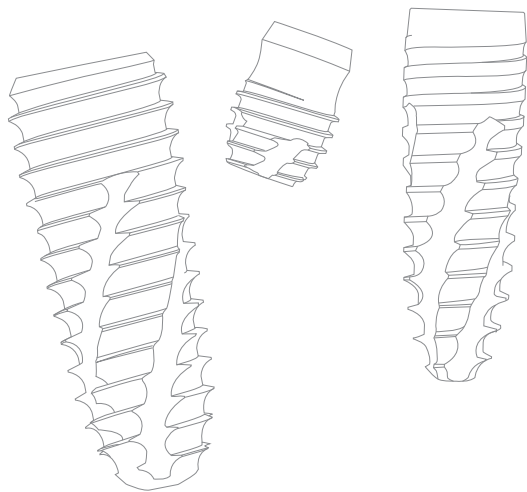

• Introduction	
Process Flow Chart	008
Package System	010
SLA-SH Surface Treatment	014

• INNO Implant System	
INNO Implant Design	024
Abutment Prosthetic Protocol	028
INNO Submerged / X / V / Short Implant	030
INNO Submerged Narrow Implant	064
INNO Internal Implant	074
INNO External Implant	090

• Mini Plus Implant System	
Mini Plus Implant	104



COWELL Digital Products

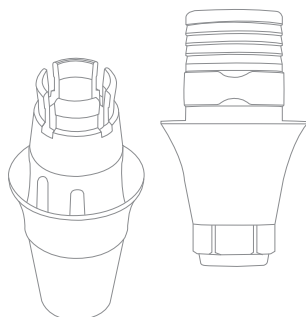

• Digital Prosthesis	
SFIT Cementless Solution(Spread-Fit)	
· Sub. SFIT Ti-Base System	111
· Sub. Multi SFIT Ti-Base System	120
· Sub-N. SFIT Ti-Base System	128
· Sub-N. Multi SFIT Ti-Base System	134

Hybrid Solution	
· Sub. Hybrid Ti-Base System	142
· Sub. Multi Hybrid Ti-Base System	148
· Sub-N. Hybrid Ti-Base System	152

Help your daily practice superior



COWELL Expert Kits

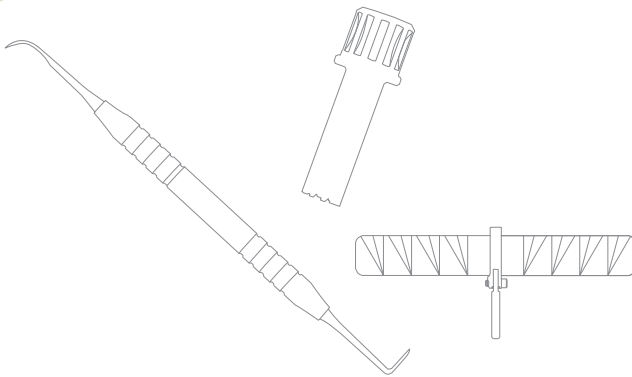

• Surgical Kits

INNO Sub. Full Surgical Kit	158
INNO Int. Full Surgical Kit	159
INNO Ext. Full Surgical Kit	160
INNO Sub. Short Surgical Kit	168
INNO Sub. Narrow Surgical Kit	170
Mini Plus Surgical Kit	172
INNO Prosthetic Planning Kit	174
INNO Prosthetic Instrument Kit	176

• Digital Guided Surgery Kits

Lodestar Plus Kit	178
Lodestar Kit	194
Lodestar Sinus Kit	206

• COWELL Expert Instrument Kits

MFS Kit (Multi-Functional Sinus Kit)	224
ESL Kit (Easy Sinus Lift Kit)	232
MFR Kit (Multi-Functional Removal Kit)	238
InnoGenic GBR Kit	242
Bone Profiler Kit	252
InnoGenic Autobone Harvester	258
COWELL BMP Trepine Kit	263
Atraumatic Extraction Kit	266
AO4 Surgical Stent	274
Volume-up Guide System	277



COWELL Regenerative Solution

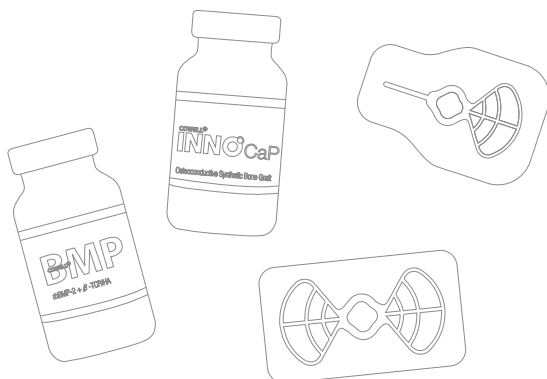

• COWELL BMP

282

• INNO-CaP

292

• InnoGraft B

295

• InnoGenic Wifi-Mesh

302

• InnoGenic PTFE-Mesh

306

COWELLMEDI HISTORY

코웰메디는 대한민국 최초 임플란트 개발을 시작으로 세계 최초로 개발된 E.rhBMP-2를 융합하여 차세대 바이오의료기기 산업을 선도하고 있습니다.

- 1994** • 1994 대한민국 최초 치과용 임플란트 개발(BioPlant, 김수홍 박사)
- 1998** • 1998 아스라히의료기기 설립
- 1999** • 1999 부산대학교 구강생물공학연구소 산학협동 연구 협약
- 2000** • 2000 ㉔코웰메디로 법인전환
- 2002** • 2002 ASD 임플란트 표면처리 개발
- 2003** • 2003 BioPlant 임플란트 시스템 미국 FDA 인증 획득
- 2004** • 2004 대한민국 최초 임플란트 개발에 대한 공로로 중소기업기술혁신대전 동탑산업훈장 수훈
- 2005** • 2005 ISO13485, KGMP 획득
- 2006** • 2006 부설 조직생물공학연구소 개소(Tissue Engineering Institute for Growth Factors)
- 2007** • 2007 rhBMP-2 코팅 임플란트 국내특허 등록
- 2008** • 2008 E.rhBMP-2 성장인자 기반 골이식재 전임상시험 완료(COWELL BMP)
- 2009** • 2009 COWELL BMP 임상시험 계획 승인(식품의약품안전처)

COWELLMEDI

[kəʊəl:medi]

Noun, singular

1. Cowellmedi is a manufacturer of dental implants, regenerative materials, instruments and The company is well known as the manufacturer that developed and launched Korea's first dental implant, called Bioplant™. As one of key players in dental healthcare industry, the company was founded in 2010, having obtained a patent in Korea and USA for its rhBMP-2 implant surface coating technology, Cowellmedi has attracted attention from the world dental community as a leading dental implant manufacturer.

- 2010** • 2010 COWELL BMP 제조품목허가 획득(식품의약품안전처)
- 2011** • 2011 rhBMP-2 코팅 임플란트 미국 특허 등록
- 2012** • 2012 INNO 임플란트 시스템 출시
- 2013** • 2013 INNO 임플란트 시스템 미국 FDA 인증 획득
- 2014** • 2014 자체 R&D 및 교육 기관 REID Global(Research & Education in Implant Dentistry) 설립
- 2015** • 2015 독자기술 임플란트 표면처리 개발(SLA-SH)
- 2016** • 2016 글로벌 임플란트 교육기관 MMS(Miami Medical Seminars)와 교육협력 체결
- 2017** • 2017 임플란트 지지 Overdenture 시스템 Sonator 출시
- 2018** • 2018 비흡수성 차폐막 Wifi-Mesh 및 PTFE-Mesh 출시
- 2019** • 2019 자사 임플란트 20년 이상의 장기임상집 출간 ("20 YEARS OF OUTCOMES, 20 YEARS OF CLINICAL EVIDENCE")
- 2020** • 2020 의료기기 단일심사프로그램 MDSAP 획득 (캐나다)
• 2020 GBR 시술기구 GBR Kit 및 시멘리스 보철 SFIT Ti-Base 시스템 출시
- 2021** • 2021 COWELL® BMP 10년 임상사례집 발간
- 2022** • 2022 코웰메디 글로벌 혁신 센터 신축 부지 확보
- 2023** • 2023 세계최초 BMP-2 서적 발간



REID Global, Research and Education in Implant Dentistry

REID Global은 Research and Education in Implant Dentistry의 약어로 2014년 코웰메디에서 설립하여 운영 중인 세계적인 치과 임플란트 임상 연구 및 교육기관입니다.

치과 임플란트 시술과 관련하여 보다 더 예측 가능하며 그 효능과 안전성이 입증된 치료술식 및 제품 개발하여 최고의 시술의 정착과 대중화에 크게 기여해 오고 있습니다.

또한 REID Global은 REID Accredited Clinician, REID Special Seminars 등의 교육 프로그램을 활용하여 심도 있는 임플란트 연수회, 세미나 및 컨퍼런스를 실시하여 우수한 치과의사, 치과의사를 가르칠 수 있는 치과의 양성에도 힘쓰고 있습니다.

체계적인 연구를 바탕으로 세계적인 강사진과 우수한 커리큘럼으로 전 세계 치과 임상 의들에게 치과 임플란트 시술 및 관련 분야에 대하여 임상 지식 및 시술을 지원하고 있습니다.

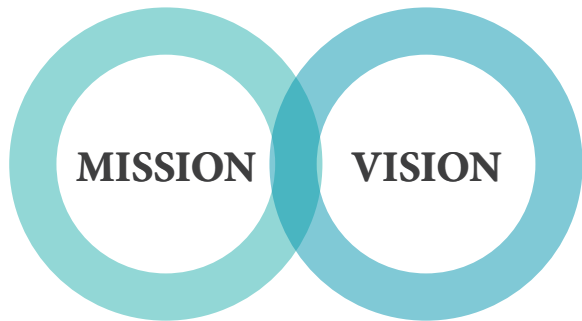

- 전 세계 치과 임상들에게 국제적으로 다학제적 치과 임플란트 교육 서비스 제공.
- 예측 가능하며 효과와 안전성이 보장된 시술법 및 제품을 제공.
- 환자의 이익을 최우선으로 포괄적인 연구를 통하여 전 세계 치과 임상들이 임플란트 시술법을 개선할 수 있도록 지원.

- 치과임플란트학 및 관련분야의 미래를 선도.
- 전 세계 회원 네트워크를 확대하여 더 많은 아이디어를 공유.
- 전 세계 모든 치과 임상이가 이용할 수 있는 교육 시스템 제공.
- 환자에게 더 많은 혜택과 편의를 줄 수 있는 시술법 개발.

Process Flow Chart

CNC 가공

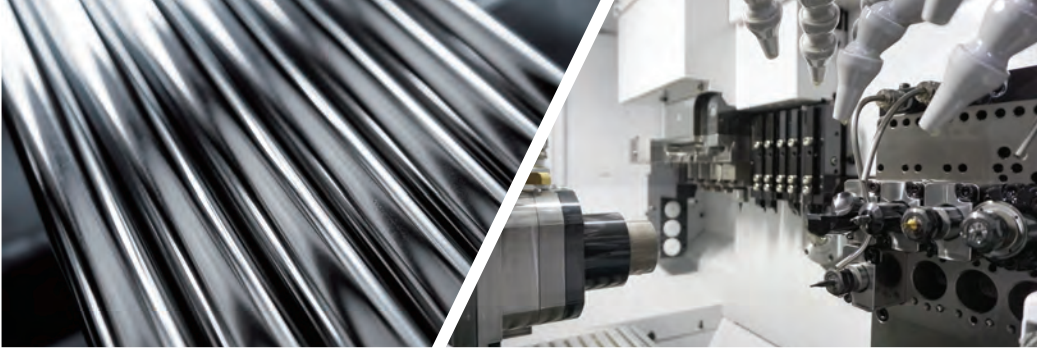

국제적으로 품질의 우수성이 검증된 티타늄 소재를 사용하여 컴퓨터 수치제어를 이용한 초정밀 기계공정으로 제품가공.



표면처리



CNC 가공 후 세척 및 검사 공정을 거친 제품을 생체친화적 재료로 Sandblasting을 실시 및 고온 강산 부식으로 표면 거칠기를 생성하여 빠른 골융합을 위한 특수 세척 공정으로 표면 에너지 활성화 구현.



검사



초정밀 계측기 등을 활용한 정확한 전수검사 및 철저한 품질 관리 시스템 가동을 통한 제품 신뢰도 강화.

세척



초음파 세척, 진공건조, 열건조소독을 거쳐 표면 잔류물이 없는 첨단 세척 시스템을 가공하고 정기 검사를 통해 우수한 세척 품질 확보.



포장 및 멸균



밀폐된 Clean Room 환경에서 위생적으로 포장된 제품을 방사성동위원소를 이용하여 Gamma 멸균 공정 시행.



보관



출하 검사 후 적합 판정을 받은 제품만 종류별로 구분되어 출하 대기.

Package System

1. Fixture type별 Color 구분과 외부 Label 표기사항

A. Fixture type별 Color 구분

Fixture type	Submerged (Sub.)	Submerged Short (Sub.)	Submerged 뽀플란트+ (Sub.)	Submerged V (Sub.)	Submerged Narrow (Sub-N.)
Package					
Connection			 Blue		 Emerald

Fixture type	Internal (Int.)	External (Ext.)	Mini Cement (1P-C.)	Mini Ball (1P-B.)
Package				
Connection	 Orange	 Green		 Pink

B. 외부 Label 표기사항

- > 멸균 포장으로 재사용 금지
- > Ampule 개봉 후 불완전 체결로 낙하에 의한 제품 손실에 유의
- > 실온의 건조한 곳에 보관하고 개봉 시 감염에 유의
- > 유효기간이 지난 제품은 폐기

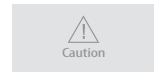
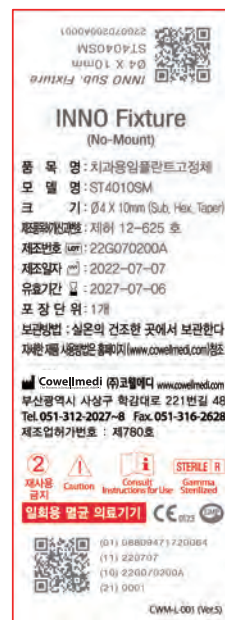

Package System

2. Fixture 사용자 설명서

COWELLMEDI IMPLANT SYSTEM 사용자 설명서

[품목명] 치과용임플란트고정체

[형 명] 해당형명기재

[등 급] 3등급

[제조업자 상호 및 주소]

부산광역시 사상구 학감대로 221번길 48 (주)코웰메디

Tel. (051) 314 - 2028 / Fax. (051) 314 - 2026

[제조업허가번호] 의료기기 제조업 제 780호

[품목 허가번호] 별도표기

[제조년월일] 제조 후 기재

[제조번호] 제조 후 기재

[유효기간] 제조일로부터 5년

[포장단위] 개 또는 세트

[사용목적]

환자의 저작기능 회복을 위해 사용하는 인공치아와 같은 보철물을 지지하기 위해 삽입되는 임플란트

[사용방법]

1. 사용 전 준비사항

1) 시술계획 및 환자진단과 선택 :

성공적인 임플란트 시술을 위하여 환자마다 의학적, 치의학적 관점에서 충분한 평가가 이루어져야 하고 임상적, 방사선적 분석 및 모델의 분석이 필수적이다. 치아 결손부위 골의 질과 양 및 골병변이 있는지 판단하여 고정체의 폭과 길이를 선택하여 해당 제품을 결정한다.

사용전에 제품에 이물질이나 불순물, 오염 여부와 포장의 손상으로 인한 멸균유지 실패 및 유효기간 확인을 한다.

2) 수술 준비사항 :

환자 구강내, 외를 소독제로 소독하고 수술기구를 멸균한다.

2. 사용방법

(1) 프리-마운트(Pre-Mount)용

▶ 술전에 필요한 경우에는 치면세마 및 구강청결 시술과 예방적 항생제 투여를 한다.

▶ 식립 절차는 수술부위와 구강내외에 소독하고 국소마취를 한다.

▶ 발거된 부위의 치조용선을 따라 절개하여 점막판막을 거상함으로써 악골을 노출시킨다.

▶ 노출된 악골의 식립하려는 부위에 고정체의 폭 및 길이에 맞는 드릴을 선정하여 지정된 시퀀스대로 드릴링을 실시한 후 고정체를 식립한다.

이 때 드릴링의 최대속도는 1,200rpm 이하이며 드릴링 시 식염수를 뿌려주어 뼈의 과사를 방지한다. 고정체는 골질에 따라 15~50N.cm의 토크(Torque)로 식립한다. 이 때 식립감이 무리가 있을 경우 카운트싱크(Countersink) 및 탭 드릴(Tap Drill)로 고정체의 식립이 용이하도록 골폭을 넓혀준다.

▶ 식립 후에 고정체를 커버 스크류(Cover Screw)로 5N.cm의 힘으로 체결하고 절개면을 봉합한다.

(2) 노-마운트(No-Mount) 용

▶ 술전에 필요한 경우에는 치면세마 및 구강청결 시술과 예방적 항생제 투여를 한다.

▶ 식립 절차는 수술부위와 구강내외에 소독하고 국소마취를 한다.

▶ 발거된 부위의 치조용선을 따라 절개하여 점막판막을 거상함으로써 악골을 노출시킨다.

▶ 노출된 악골의 식립하려는 부위에 고정체의 폭 및 길이에 맞는 드릴을 선정하여 지정된 시퀀스대로 드릴링을 실시한 후 고정체를 식립한다.

이 때 드릴링의 최대 속도는 1,200rpm이하이며 드릴링 시 식염수를 뿌려주어 뼈의 과사를 방지한다.

▶ 멸균된 앰플(Ampule)의 뚜껑을 제거하고 Hand-Piece에 No-Mount용 드라이버(Driver)를 체결 하고 고정체를 연결시킨 후 구강 내 식립부위에 넣고 식립한다.

▶ 골질에 따라 15~50N.cm의 토크(Torque)로 고정체를 식립한다. 이 때 식립감이 무리가 있을 경우 카운트싱크(Countersink) 및 탭 드릴(Tap Drill)로 고정체의 식립이 용이하도록 골폭을 넓혀 주며, 식립 속도는 25~30rpm 이하로 한다.

▶ 식립 후에 고정체를 커버 스크류(Cover Screw)로 10N.cm의 힘으로 체결하고 절개면을 봉합한다.

2) 2차수술

(1) 골융합이 완료된 후 식립된 고정체 상부의 치운을 절개하여 덮개 나사를 제거하고, 힐링 어버트먼트(Healing Abutment)를 체결 하고 보철을 위한 치은 치료 및 형성에 들어간다.

(2) 통상적인 보철을 만드는 방법으로 제작하여 수술을 완료한다.

3. 주의사항

1) 부작용

골질이 고정체에 직접 결합하지 않고 연조직으로 결합이 되면 제거 하여야 한다.

2) 금기사항

전신적인 병력으로 외과적 처치를 하기 어려운 경우와 급성 골수염이 있는 경우에는 시술을 금기한다.

3) 경고사항

(1) 초기 고정을 얻지 못하거나 치유기간 중에 고정체에 고착력이 부하되면 골 결합이 안될 수 있다.

(2) 과도한 토크(Torque)로 식립 시 뼈의 과사를 초래할 수 있으며 시술 실패의 원인이 될 수 있으니 골폭을 충분히 확보시켜 시술 한다.

(3) 합병증이 유발될 수 있는 환자에게는 시술자가 충분한 검토 후 시술한다.

(4) No-Mount용의 경우 앰플(Ampule) 개봉 후 No-Mount 용 드라이버(Driver)를 체결 시 완전한 체결이 되지 않고 구강내로 이동 시 No-Mount 용 드라이버가 고정체와 분리되어 낙하로 인한 고정체의 손실이 발생할 수 있으니 완전히 체결하여 이동한다.

(5) 이노 쇼트 고정체(INNo Short Fixture)의 경우 골 식립부의 길이가 6.0mm. 직경 5.0mm 이상인 고정체는 구치부에 한해 사용하며, 사용시 단독으로 사용하지 않는다.

(6) 치유기간

상악은 골질에 따라 6개월에서 8개월의 치유기간을 가져야 하고 하악은 골질에 따라 3개월에서 5개월의 치유기간을 가져야 한다. 치유기간 중에는 고정체에 저작압 등의 압력이 가해지지 않아야 한다. 골재생술이 동반된 경우에는 5개월 이상의 치유기간을 가져야 한다 (멸균제품임).

시술자가 충분한 골융합이 확보되었다고 판단이 되면 보철제작을 위한 단계에 들어간다.

4. 권고사항 [이노 쇼트 고정체(INNO Short Fixture) 사용 시]

1) 보철 시술 시 다른 임플란트와 연결하여 사용한다.

2) 충분한 치유기간 후 보철을 실시한다.

5. 사용 후 보관 및 관리방법

일회용으로 포장지를 개봉하면 재사용하지 않으며 실은 건조한 곳에서 보관한다.

*** 본제품은 일회용 의료기기임**

6. 멸균방법

감마멸균으로 ISO11137 기준에 따른다.

Cowellmedi (주)코웰메디 Cowellmedi Co., Ltd.

부산광역시 사상구 학감대로 221번길 48

Tel. 051-312-2027~8 Fax. 051-316-2628

http://www.cowellmedi.com

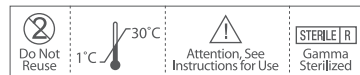

3. Fixture 포장 개봉 및 제품 추출 순서



Ampule 추출



1 상단 점선 부위를 눌러 개봉한 후 멸균된 상태의 Blister 추출



2 Blister 뒷면의 습포지를 제거한 후 Ampule을 시술자의 손바닥이나 수술보에 올려 놓음

Fixture 분리



1 Ampule을 양손으로 잡고 45°비틀어 Middle을 분리, 이 때 Fixture가 떨어지지 않도록 주의



2 No-Mount의 경우 Fixture Driver로 체결하고 Pre-Mount는 Mount Driver로 체결

Cover Screw 분리

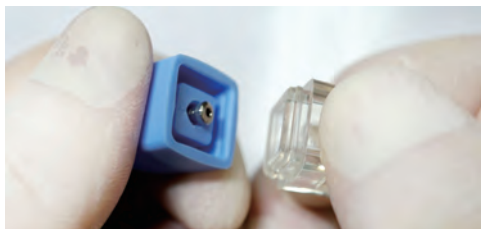

1 Ampule 상단의 Upper part 분리



2 Hex Driver를 이용하여 Cover Screw를 Fixture에 체결 (환자가 삼키지 않도록 주의)

4. Abutment 포장 및 외부 Label 표기사항



5. Kit 포장 및 외부 Label 표기사항



SLA-SH, Cell-to-cell Communication을 완성하다

Made with the longest experience in Korea

균일한 미세 표면
Geometry 및 BIC 최대화로 골융합 가속화



Surface Treatment: SLA-SH Cell to cell communication을 완성하다

- > 특수 기술을 이용하여 장기간 유지되는 표면으로 원내에서 UV 및 Plasma 등의 별도 공정 불필요.
- > BMP Coating 임플란트 시술에 최적화.
- > 여타의 임플란트 표면과 달리 산화알루미늄을 사용하지 않고 생체친화적 재료로 Sandblasting된 인체친화적 표면.
- > 120Ncm의 강한 힘에도 표면이 무너지지 않는 강력한 표면 Stability.
- > 골과 임플란트 접촉 면적 최대화(BIC, Bone to Implant Contact).

1. 정밀한 산부식 처리로 균일한 Macropore와 Micropore를 형성함으로 골 유착의 가속화 실현

A. SLA-SH가 적용된 INNO 임플란트의 표면 3,000, 5,000, 100,000배 및 200,000배 확대

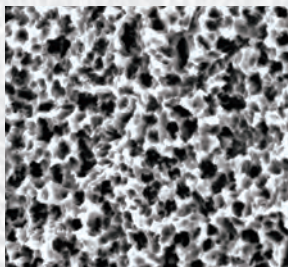

Macro, Micro-Fit / 3,000X

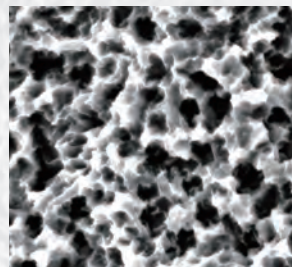

Macro, Micro-Fit / 5,000X

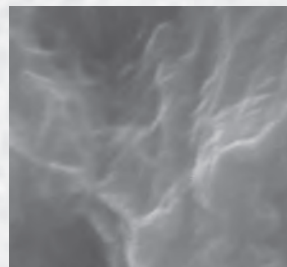

Nano-Fit(Roughness) / 100,000X

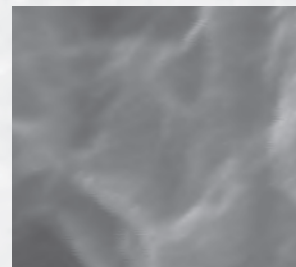

Nano-Fit(Roughness) / 200,000X

B. 현재 판매 중인 유사 표면처리 적용 임플란트 표면 비교

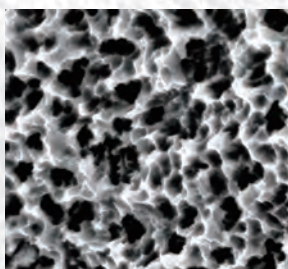

Cowellmedi / 80Ncm / 5,000X

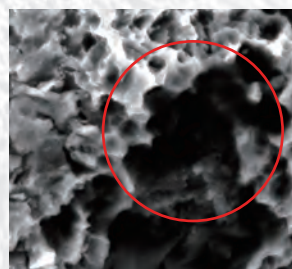

Company A / 80Ncm / 5,000X

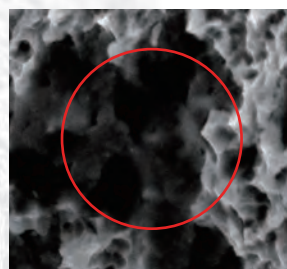

Company B / 80Ncm / 5,000X

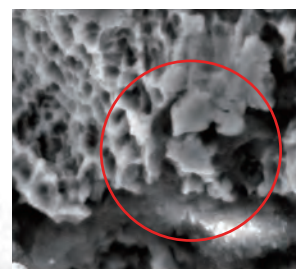

Company C / 80Ncm / 5,000X

Company	Torque(Ncm)	Macro, Micro-fit Extinction Size	Result
Cowellmedi	40N	N/D	Micro-fit Survival
	80N	N/D	Micro-fit Survival
Company A	40N	N/D	Micro-fit Survival
	80N	6.5 ~ 33.3 μ m	Micro-fit Extinction
Company B	40N	9.7 ~ 39.7 μ m	Micro-fit Extinction
	80N	10.8 ~ 39.4 μ m	Micro-fit Extinction
Company C	40N	N/D	Micro-fit Survival
	80N	9.5 ~ 64.3 μ m	Micro-fit Extinction

> SLA-SH는 Macro, Micro, Nano-fit이 견고하며, 과식립 토크에도 Macro, Micro, Nano-fit은 우수한 생존을 가집니다.

2. SSEM 3D 이미지를 활용한 표면 거칠기 평가

A. SLA-SH 적용된 INNO 임플란트의 표면

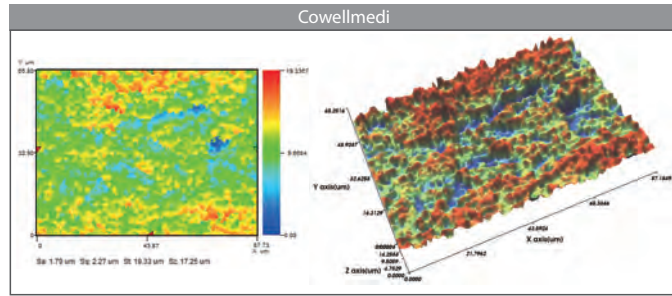
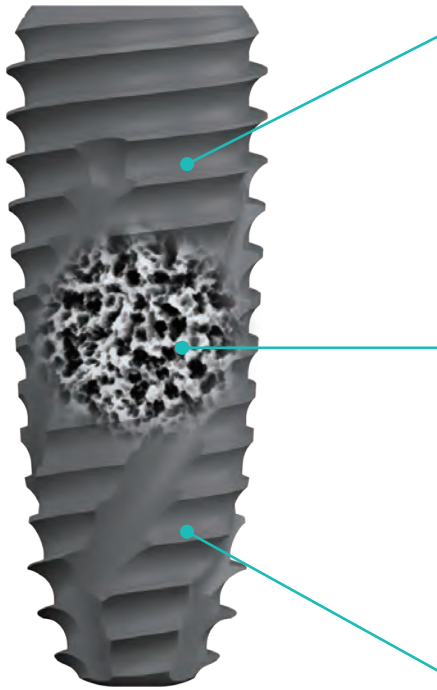

Sa : 1.79 μm Sq : 2.27 μm St : 19.33 μm Sz : 17.25 μm

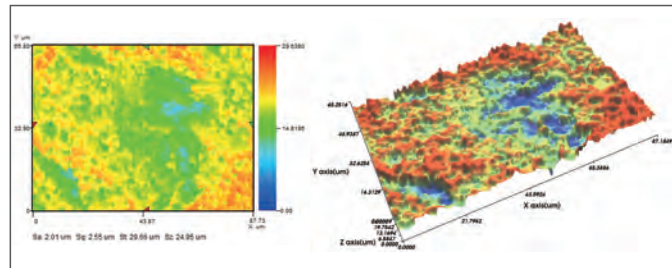

Sa : 2.01 μm Sq : 2.55 μm St : 29.66 μm Sz : 24.95 μm

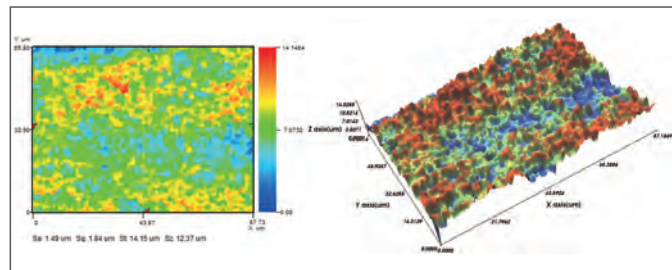

Sa : 1.49 μm Sq : 1.84 μm St : 14.15 μm Sz : 12.37 μm

B. 현재 시판 중인 다른 SLA 처리 임플란트의 표면적 증가 비교

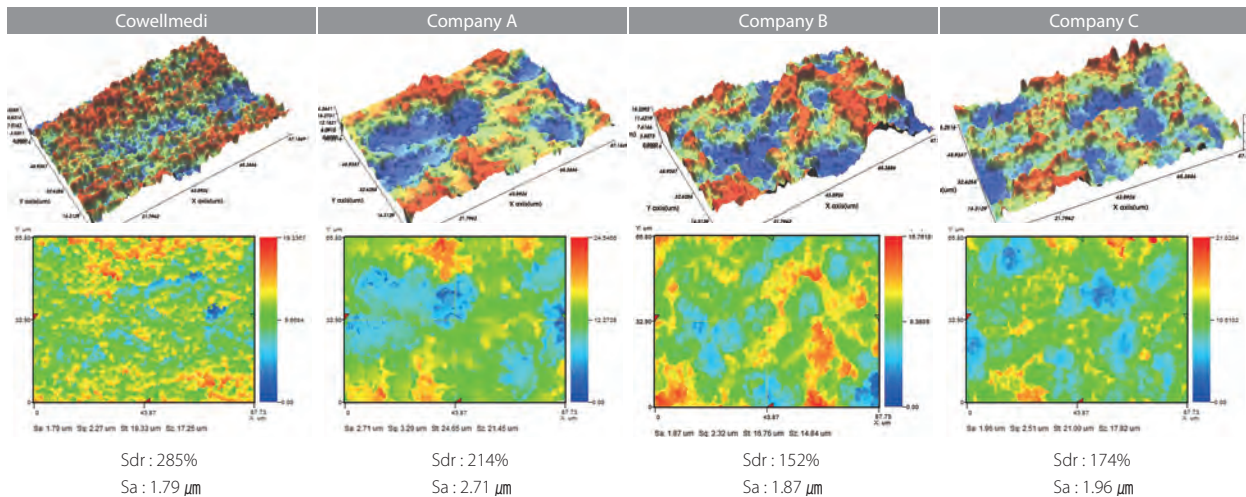

*Sdr : Surface area increase rate

> SLA-SH의 Micro-fit은 타사 대비 우수한 표면적증가를 보유하고 있으며, 골유착에 중요한 요소인 적정 거칠기와 표면적을 확대 하였습니다.

3. 친수성 표면으로 표면 활성 증가

A. 생리식염수와 현재 판매 중인 유사 표면처리 적용 임플란트 표면의 접촉각 측정 결과

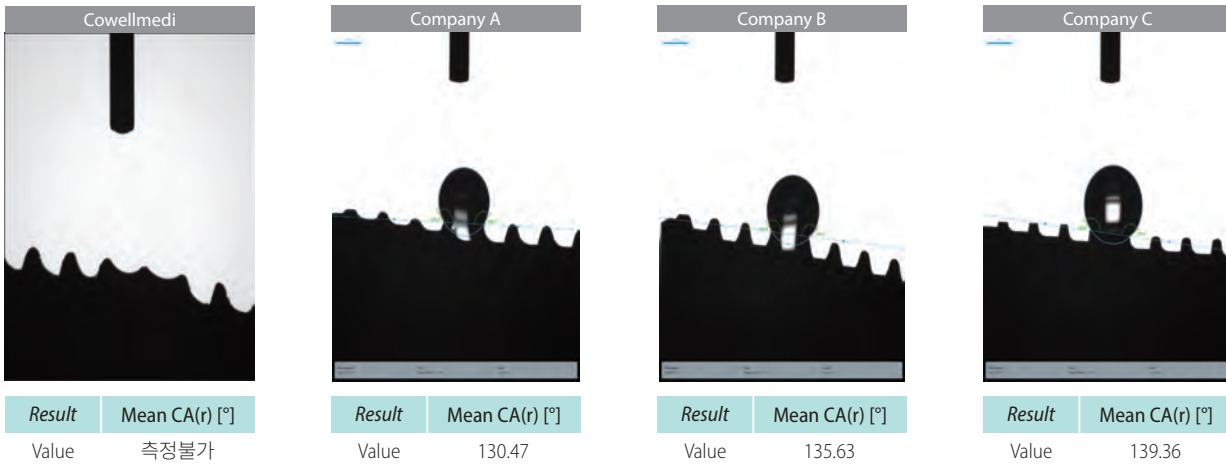

> SLA 처리 후 친수성 처리를 거쳐 표면 에너지가 증가하여 골세포의 부착이 더욱 유리해져 빠른 골융합을 가능하게 함.



실제 임상에서의 혈액의 침투가 촉진되는 모세관 현상

빠른 혈액 침투

B. 표면 거칠기와 표면 친수성의 연관성

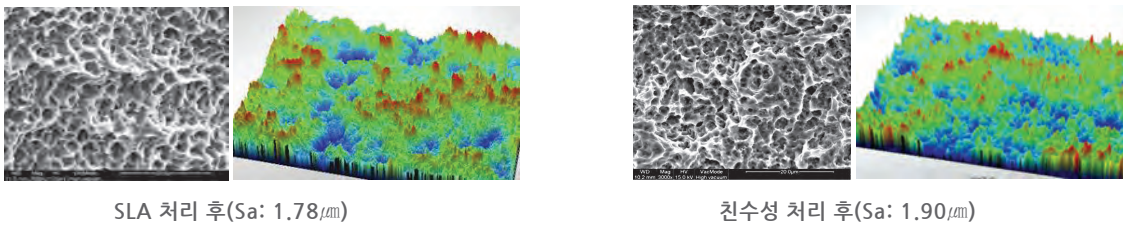

> 친수성 처리 후 표면 거칠기나 미세 형상의 차이가 거의 나타나지 않으며 표면 친수성의 차이는 친수성 처리에 의한 표면 에너지와 같은 물리화학적 성질이 작용한다는 것을 알 수 있음.

C. Physicochemical alteration of surface by hydrophilic activation treatment

Name	Start BE	Peak BE	End BE
C1s	290	284.6	280.5
O1s	535.3	530.42	525.6
Ti2p	468.1	458.78	450.4

SLA 처리 후

Name	Start BE	Peak BE	End BE
C1s	290.46	284.6	284.6
O1s	538.8	533.73	529.3
Ti2p	468.2	456.76	453.4

친수성 처리 후

> 친수성 처리 후에는 C1s, O1s, Ti2p의 에너지가 부위별로 증가되어 표면 친수성 향상.

> 특수 공법을 사용하여 표면의 친수성을 장기간 유지하여 원내에서 별도 공정이 필요 없음.

4. 조직형태 계측학적 분석(BIC, BAPO)

A. 대조군(Company), 실험군(INNO) 간 골접촉도(Bone to Implant Contact; BIC) 비교

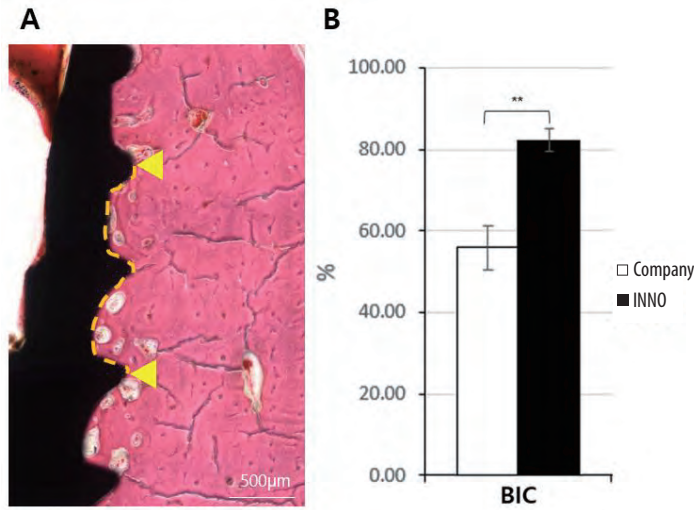

> (A) BIC 분석 대표 이미지, (B) 8주차 BIC 비교 그래프.

> Data are expressed as mean ± standard error. **p<0.01 vs Company.

B. 대조군(Company), 실험군(INNO) 간 골면적(Bone Area Fraction Occupancy; BAPO) 비교

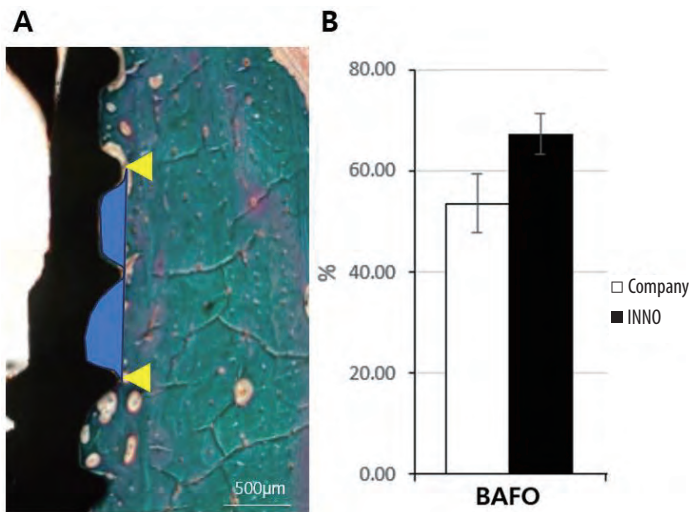

> (A) BAPO 분석 대표 이미지, (B) 8주차 BAPO 비교 그래프.

> Data are expressed as mean ± standard error.

> 골 접촉도(Bone to implant contact; BIC)는 나사 중간 부위 좌우 각각 2개 나사선 길이에 대해 나사선과 골조직이 접촉하고 있는 길이를 %로 계산하여 평균값을 비교분석하였음. 8주차에서 대조군(55.9±13.37%)에 비해 실험군(82.25±6.96%)에서 유의적으로(p<0.01) BIC가 높게 확인됨(A). 골 면적(Bone Area Fraction Occupancy; BAFO)은 나사 중간 부위 좌우 각각 2개 나사선 사이의 전체 면적에 대해 신생골 조직이 차지하고 있는 골 면적 비율을 %로 계산하여 평균값을 비교분석하였음. 8주차에서 유의성은 관찰되지 않았으나 대조군(53.61±14.34%)에 비해 실험군(67.34±10.01%)에서 BAFO가 높은 경향이 확인됨(B)

*출처 : 엔알피코리아



대한민국 임플란트의 시작

코웰메디 임플란트

INNO Implant

- 30년이 넘는 장기 데이터로 제품 개발
- 수십 년간의 연구를 바탕으로 개발된 표면처리
- 다양한 증례에 최적화된 우수한 디자인



[1994] Bioplant

대한민국 최초
국산 임플란트
(김수홍 박사)

[2002] Axis

약한 골질에 특화된
썩기형 임플란트

[2004] 동탑산업훈장

국산 최초 임플란트
개발의 공로로 훈장 수훈
(김수홍 박사)

[2010] COWELL BMP

세계 최초 E.Coli 유래
rhBMP-2 기반
골이식재 출시

발치와 즉시 식립, 상악동 등
다양한 증례에 최적화된 디자인,
특수표면처리로 표면 젖음성
극대화

[2012] INNO Implant

Spread Fit SFIT
Cementless Solution
공식 런칭

[2020] SFIT



세계최초
rhBMP-2 서적 발간

[2023] rhBMP-2 서적

COWELL IMPLANT SYSTEM

Help your daily practice superior



INNO Submerged

즉시 임플란트 식립, 즉시 부하, 식립 깊이 조절 및 상악동을 포함한 다양한 증례에 사용될 수 있도록 개발된 코웰메디의 Flagship 임플란트



INNO Submerged Narrow

전치부의 좁은 Alveolar ridge에 사용되며 Double tapered thread가 Wedge action을 통해 더 높은 Primary stability 제공함

COWELL®
IMPLANT
SYSTEM

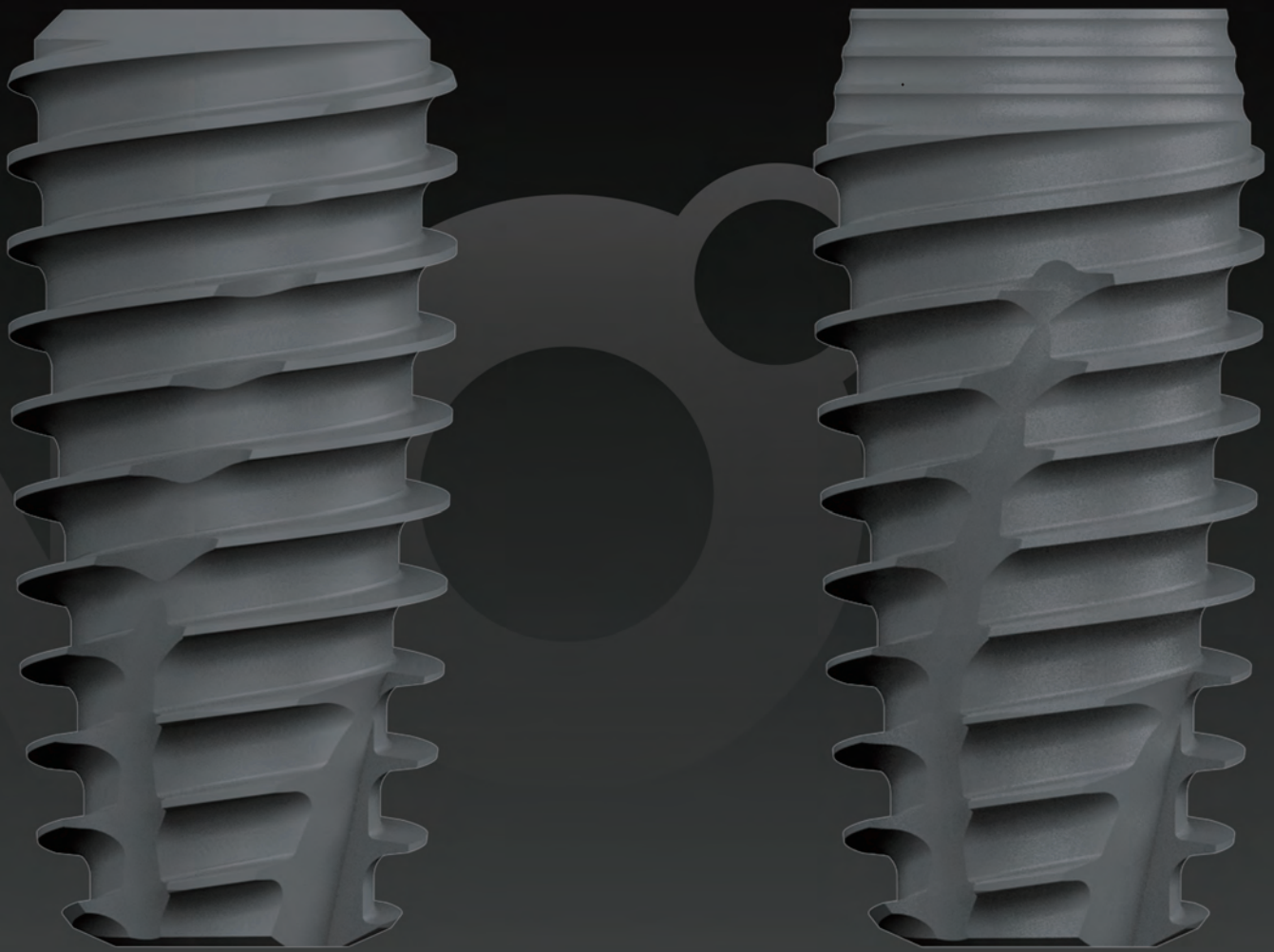

INNO 뼈플란트+ / V

독창적인 Trapezoid Buttress thread와 넓고 깊은 Body Thread로
모든 골질에서 우수한 초기 고정력과 안정성을 제공하며,
즉시 식립 및 다양한 임상 케이스에 최적화된 코웰메디의 혁신적 임플란트

COWELL IMPLANT SYSTEM

Help your daily practice superior



INNO Submerged Short

하악 구치부 등에 심한 골흡수가 있는
증례를 수복하기 위해 고안되었으며
넓고 깊은 상단 Thread는 피지골의 압박을 방지함

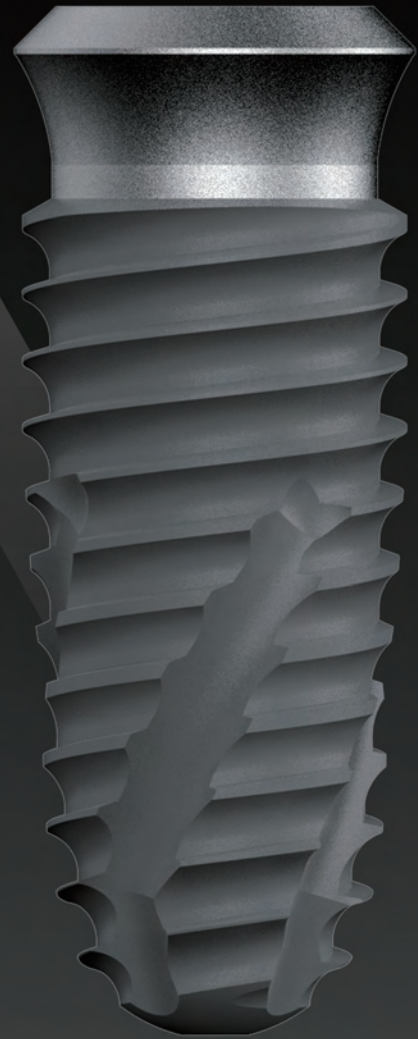

INNO Internal

Tissue level 임플란트 시술을 위한 임플란트로
4개의 나선 원형의 날카로운 Cutting edge는
Self-tapping의 효율성 극대화하고 Bone chip을
Cutting edge의 Pocket에 수용하여 빠른 골융착을 도움

COWELL®
IMPLANT
SYSTEM



INNO External

가장 고전적인 연결부를 가진 임플란트로 개방형 Thread가 있는 Platform neck은 골과 임플란트 경계면에서 골막의 안정적인 생착을 유도함



Mini Plus

하악 전치부 및 무치악 등에 매우 좁은 Ridge를 위한 반영구적 또는 임시 수복용 임플란트

INNO Implant Design

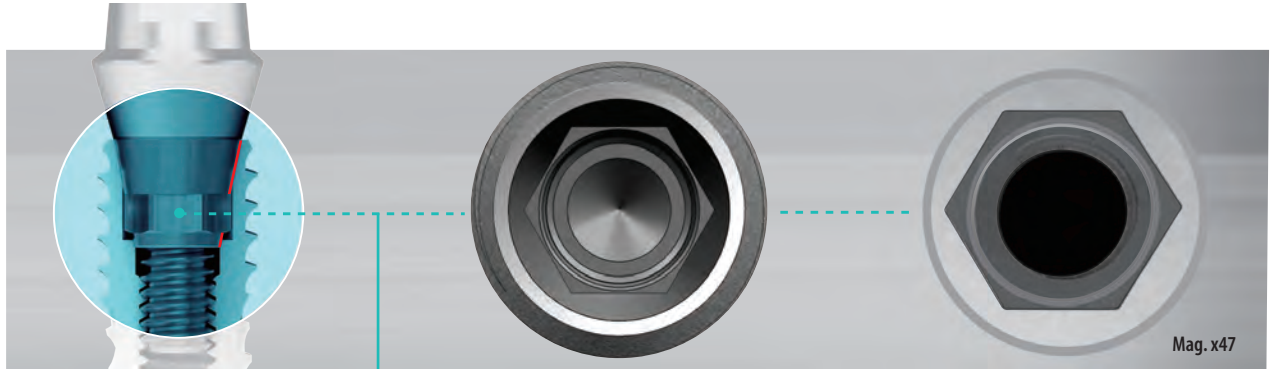

Tapered Hex Connection with Double Contacts

- > Fixture와 상부 구조물의 완벽한 결합으로 이상적인 cold welding을 발생시키며 미세 침하 방지
- > Micromovement 최소화 및 Stress 분산
- > Stand hex type으로 타사 제품과 우수한 호환성

Wide and Deep Upper Threads

- > Cortical bone의 Compressive necrosis 방지
- > Countersink drill의 필요성 최소화
- > 두께 강화로 기계적 강도 강화

Double Tapered Threads

- > 발치와나 골질이 약한 부위에서도 초기 고정력 확보
- > Drill홀에 Fixture 절반 길이가 삽입된 상태로 안착되어 2~4회전만으로 식립 완성
- > 반 바퀴 추가 회전으로도 Wedge action으로 더 높은 초기 고정력 획득

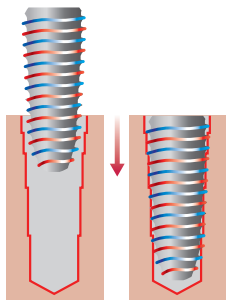

기진입량 5mm 이상과 Double thread로 인하여 식립 시간 단축

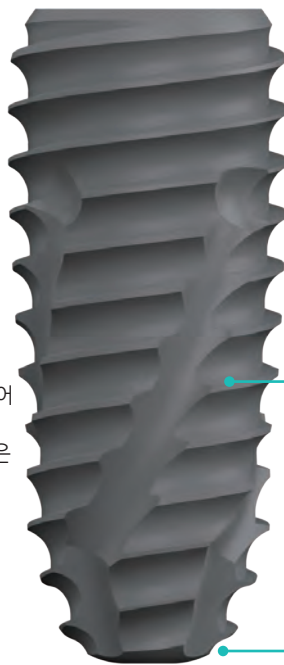

Platform Neck

- > Bone과 Implant의 경계면에 골막의 안정적 생착
- > Implant 주위 염증 방지

Open Threads

- > 추가 Drilling 없이도 더 깊이 매식 가능

4 Spiral Round Cutting Edges

- > Sharp edge로 Self tapping 효율성 극대화
- > 이상적인 Cutting edge pocket 공간으로 Bone chip 수용

Concave Apex Threads with Sharp Cutting Edges

- > Drill 하단부 초기 고정 획득
- > Schneiderian membrane 천공을 방지하며 거상에 유리한 구조



※ 골질 D2 test block의 5.0 및 5.5mm 깊이의 Hole에 Ø4.5x10mm의 각기 다른 4가지 Fixture(각 4개)를 식립했을 때 발생하는 평균 Torque force의 비교

Classification	INNO	A	B	C
Depth 5.0mm	26.2 Ncm	29.2 Ncm	26.8 Ncm	28.4 Ncm
Depth 5.5mm	44.0 Ncm	38.0 Ncm	34.4 Ncm	38.5 Ncm

INNO X Implant Design

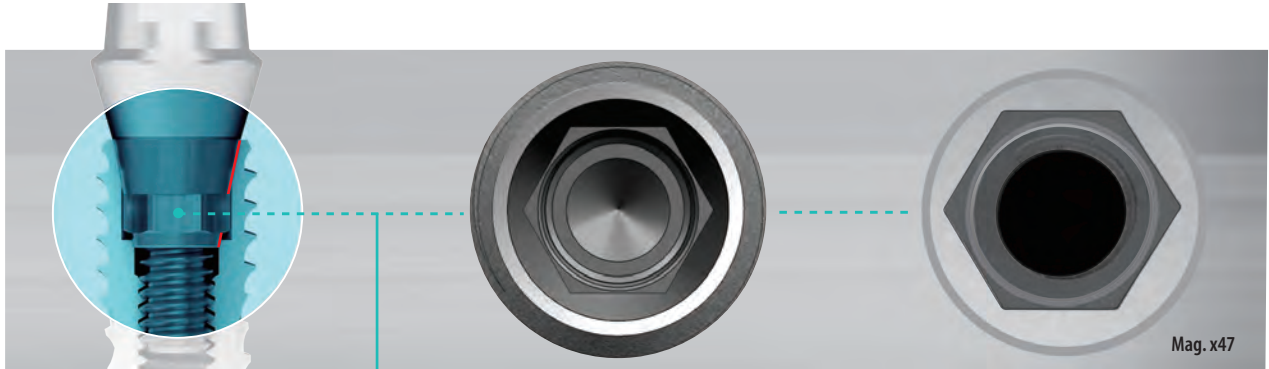

Tapered Hex Connection with Double Contacts

- > Fixture와 상부 구조물의 완벽한 결합으로 이상적인 cold welding을 발생시키며 미세 침하 방지
- > Micromovement 최소화 및 Stress 분산
- > Stand hex type으로 타사 제품과 우수한 호환성

Wide and Deep Upper Threads

- > Cortical bone의 Compressive necrosis 방지
- > Countersink drill의 필요성 최소화
- > 두께 강화로 기계적 강도 강화

Double Tapered Threads

- > 발치와나 골질이 약한 부위에서도 초기 고정력 확보
- > Drill홀에 Fixture 절반 길이가 삽입된 상태로 안착되어 2~4회전만으로 식립 완성
- > 반 바퀴 추가 회전으로도 Wedge action으로 더 높은 초기 고정력 획득

2 Spiral Round Cutting Edges

- > Sharp edge로 Self tapping 효율성 극대화
- > 이상적인 Cutting edge pocket 공간으로 Bone chip 수용

Platform Neck

- > Bone과 Implant의 경계면에 골막의 안정적 생착
- > Implant 주위 염증 방지
- > Crestal Bone에 가해지는 Stress를 줄여 Crestal Bone loss 최소화

Open Threads

- > 추가 Drilling 없이도 더 깊이 매식 가능

Wide & Deep Body Thread

- > 깊고 넓은(0.9Pitch) Thread로 인하여 골-임플란트 계면의 기능적 표면적을 증가시켜 저밀도 분이나 교합부하가 높은 부위에서 일차적 안정성 향상

2 Flat Cutting Edge

- > 잇몸뼈 압력을 최소화 하며 Self Tapping 능력 향상

Flat Apex Thread

- > 드릴 하단부 초기고정 획득
- > 발치와 즉시 식립에 유리
- > 인접본 응력분포 유리



- > 2 Spiral Round Cutting Edges
- > 2 Flat Cutting Edge

Trapezoid Buttress thread

- > 응력분산에 가장 유리한 기본 사다리꼴 모양의 Thread에 리버스 버트리스 구조가 접목 되어 D1~D4 어떠한 골질에서도 초기고정력을 얻을 수있는 코웰메디만의 독창적인 디자인. 이 디자인은 Compressive Force로 인한 본압박을 최소화하며 응력분산도 매우 유리

INNO V Implant Design

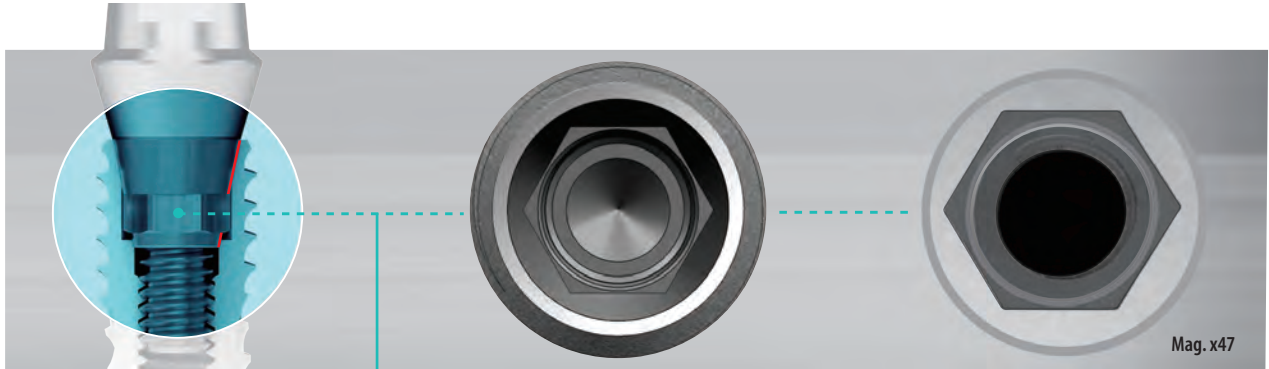

Tapered Hex Connection with Double Contacts

- > Fixture와 상부 구조물의 완벽한 결합으로 이상적인 cold welding을 발생시키며 미세 침하 방지
- > Micromovement 최소화 및 Stress 분산
- > Stand hex type으로 타사 제품과 우수한 호환성

Wide and Deep Upper Threads

- > Cortical bone의 Compressive necrosis 방지
- > Countersink drill의 필요성 최소화
- > 두께 강화로 기계적 강도 강화

Double Tapered Threads

- > 발치와나 골질이 약한 부위에서도 초기 고정력 확보
- > Drill홀에 Fixture 절반 길이가 삽입된 상태로 안착되어 2~4회전만으로 식립 완성
- > 반 바퀴 추가 회전으로도 Wedge action으로 더 높은 초기 고정력 획득

2 Spiral Round Cutting Edges

- > Sharp edge로 Self tapping 효율성 극대화
- > 이상적인 Cutting edge pocket 공간으로 Bone chip 수용



- > 2 Spiral Round Cutting Edges
- > 2 Flat Cutting Edge

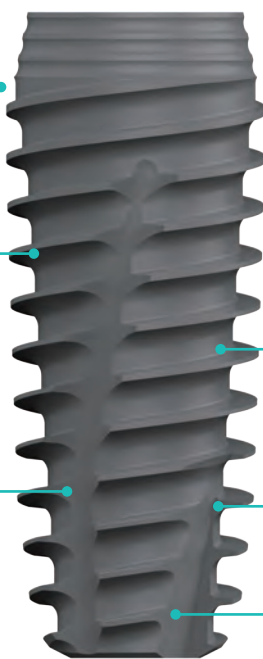

Platform Neck

- > Bone과 Implant의 경계면에 골막의 안정적 생착
- > Implant 주위 염증 방지
- > 3개의 Groove로 인한 Platform switching 효과로 Crestal Bone에 가해지는 Stress를 줄여 Crestal Bone loss 최소화

Open Threads

- > 추가 Drilling 없이도 더 깊이 매식 가능

Wide & Deep Body Thread

- > 깊고 넓은(0.9Pitch) Thread로 인하여 골-임플란트 계면의 기능적 표면적을 증가시켜 저밀도 분이나 교합부하가 높은 부위에서 일차적 안정성 향상

2 Flat Cutting Edge

- > 잇몸뼈 압력을 최소화 하며 Self Tapping 능력 향상

Flat Apex Thread

- > 드릴 하단부 초기고정 획득
- > 발치와 즉시 식립에 유리
- > 인접본 응력분포 유리

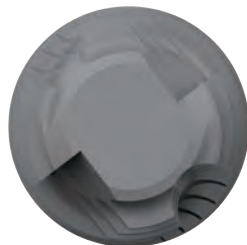

Trapezoid Buttress thread

- > 응력분산에 가장 유리한 기본 사다리꼴 모양의 Thread에 리버스 버트리스 구조가 접목 되어 D1~D4 어떠한 골질에서도 초기고정력을 얻을 수 있는 코웬메디만의 독창적인 디자인. 이 디자인은 Compressive Force로 인한 본압박을 최소화하며 응력분산도 매우 유리

임플란트 즉시 식립, 식립 즉시 부하, 식립 깊이 조절 및 상악동, 발치와 등 다양한 임상증례에 유리한 INNO Implant System

Fixture type	Submerged (Sub.)	Submerged Short (Sub.)	Submerged Narrow (Sub-N.)	Internal (Int.)	External (Ext.)
Fixture Design	<p>INNO INNO X INNO V</p>				
Connection	<p>SUB. HEXAGON SYSTEM</p>		<p>SUB-N. HEXAGON SYSTEM</p>	<p>INT. OCTAGON SYSTEM</p>	<p>EXT. HEXAGON SYSTEM</p>

간편하고 안전한 Surgical Kit

Sub. / Sub. Short / Sub-N. / Int. / Ext. 각 Type별 전용 Surgical Kit 구비

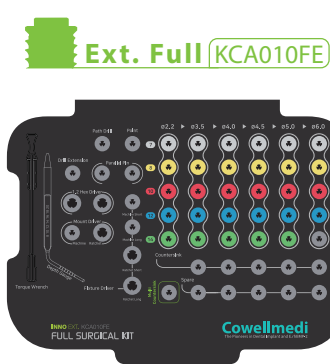
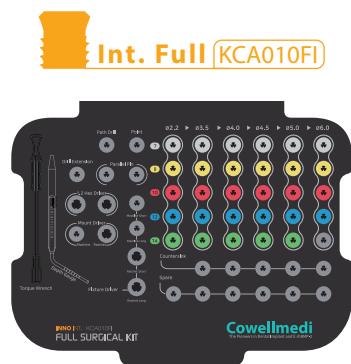
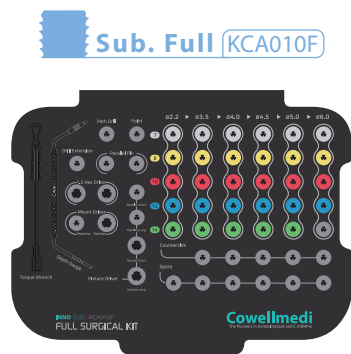

All in One Drill: Initial Drill과 Final Drill를 이용한 간단한 Drilling sequence

일반 골질에서 3회의 Drilling으로 Fixture 식립 완료(Ø3.5~4.5 fixture 식립 시)

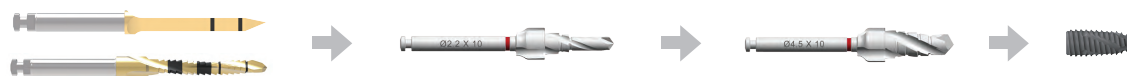

Abutment Prosthetic Protocol

> 디지털 임플란트 보철은 COWELL DIGITAL PRODUCTS 페이지에서 참고하세요.

1. Fixture Level Impression 보철 제작

* 2 Piece Screw Retained Abutment

Submerged: Temporary, Meta G UCLA, Plastic UCLA

Submerged Narrow: Temporary

Internal: Meta G UCLA

External: Temporary, Meta G UCLA, Plastic UCLA

* 2 Piece Screw-Cement Retained / Cement Retained Abutment

Submerged: Cemented, Angulated, Beauty-up, Milling

Submerged Narrow: Cemented, Angulated

Internal: Cemented, Angulated

External: Cemented, Angulated

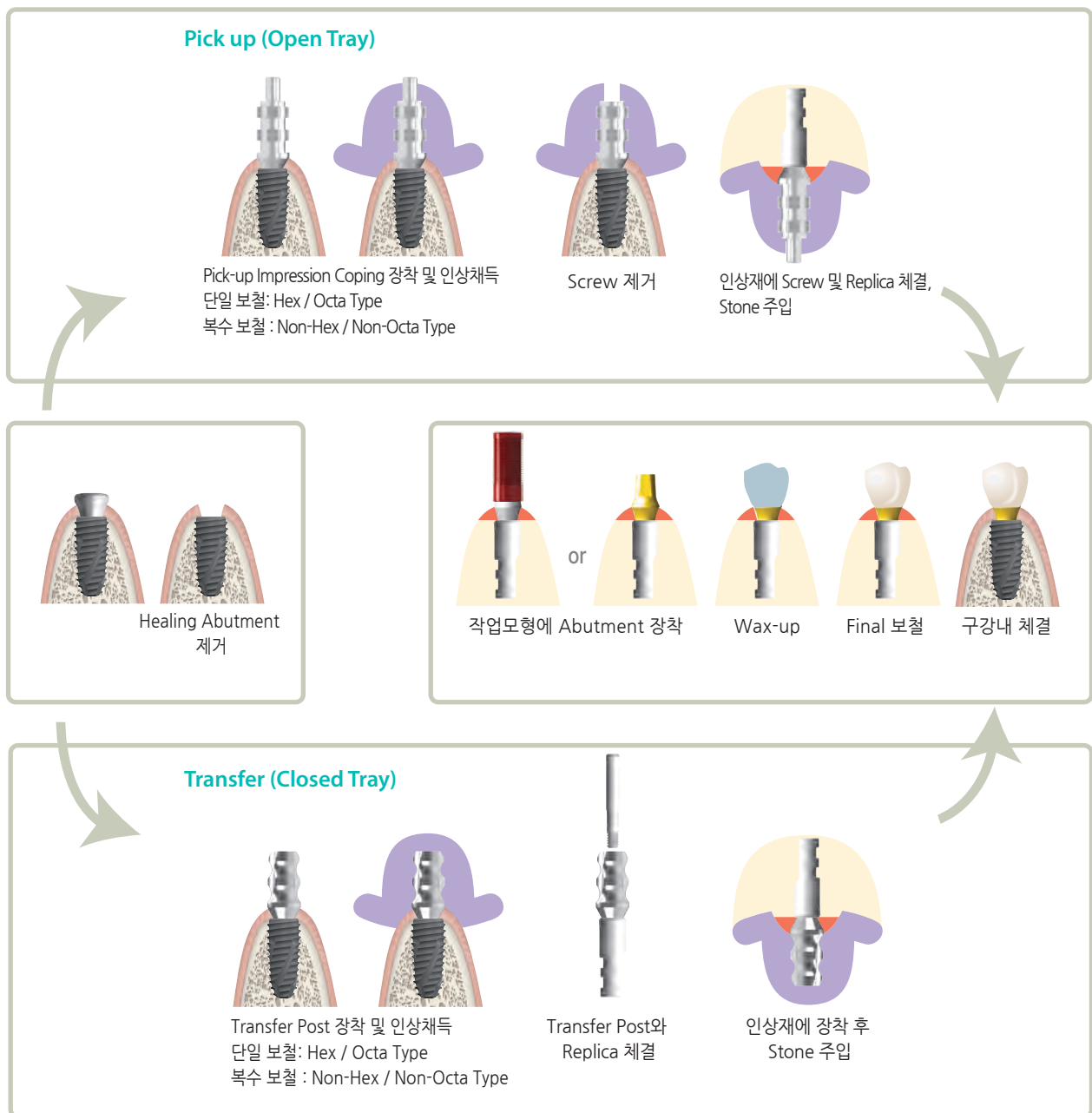

2. Abutment Level Impression 보철 제작

* 2 Piece 및 1 Piece Screw Retained Abutment

Submerged : Multi S, Multi A

* 1 Piece Cemented Retained Abutment

Submerged : Absolute, Straight

Submerged Narrow : Straight

Internal : Solid, Shoulder

External : Shoulder

* 2 Piece 및 1 Piece Attachment Retained Abutment

Submerged : Sonator S, Sonator A, Ball

Internal : Ball

External : Ball

Indirect Impression (Abutment Modification 없이 인상 채득)



















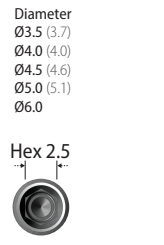

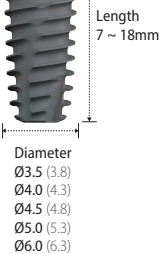

Direct Impression(Abutment Modification 후 인상 채득)

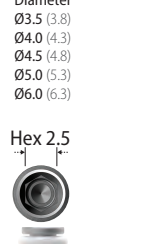

INNO SUBMERGED IMPLANT (Sub.)

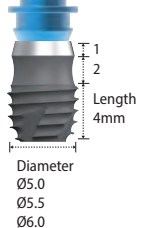
System Flow

Fixture	Abutment							
 <p>Hex 2.5 Length 7 ~ 18mm</p>	Prosthetic Procedure I	 Cemented Abutment	 Angulated Abutment	 Beauty-up Abutment	 Milling Abutment	 Temporary Abutment	 Meta G UCLA Abutment	 Plastic UCLA Abutment
 <p>Diameter Ø3.5 (3.7) Ø4.0 (4.0) Ø4.5 (4.6) Ø5.0 (5.1) Ø6.0 Hex 2.5</p>	Prosthetic Procedure II	 Multi S Abutment	 Multi A Abutment	 Multi Titanium Cylinder				
 <p>Hex 2.5 Length 7 ~ 18mm</p>	Prosthetic Procedure III	 Absolute Abutment						
 <p>Hex 2.5 Length 7 ~ 18mm</p>	Prosthetic Procedure IV	 Straight Abutment						
 <p>Diameter Ø3.5 (3.8) Ø4.0 (4.3) Ø4.5 (4.8) Ø5.0 (5.3) Ø6.0 (6.3) Hex 2.5</p>	Prosthetic Procedure V	 Sonator S Abutment	 Sonator A Abutment					
 <p>Hex 2.5 Length 4mm</p>	Prosthetic Procedure VI	 Ball Abutment						

Impression

Fixture Level Impression

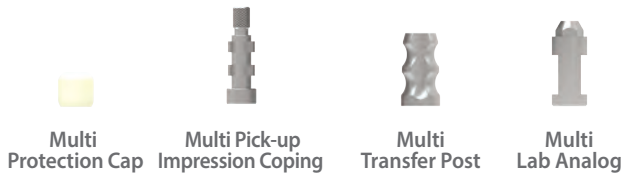

Abutment Level Impression

Direct Impression



INNO Submerged Implant



Submerged Fixture
Surface Treatment: **SLA-SH**

- > Interchangeable with hexagonal morse tapered fixture
- > Internal hex connection (Taper 11°/ Hex 2.5)

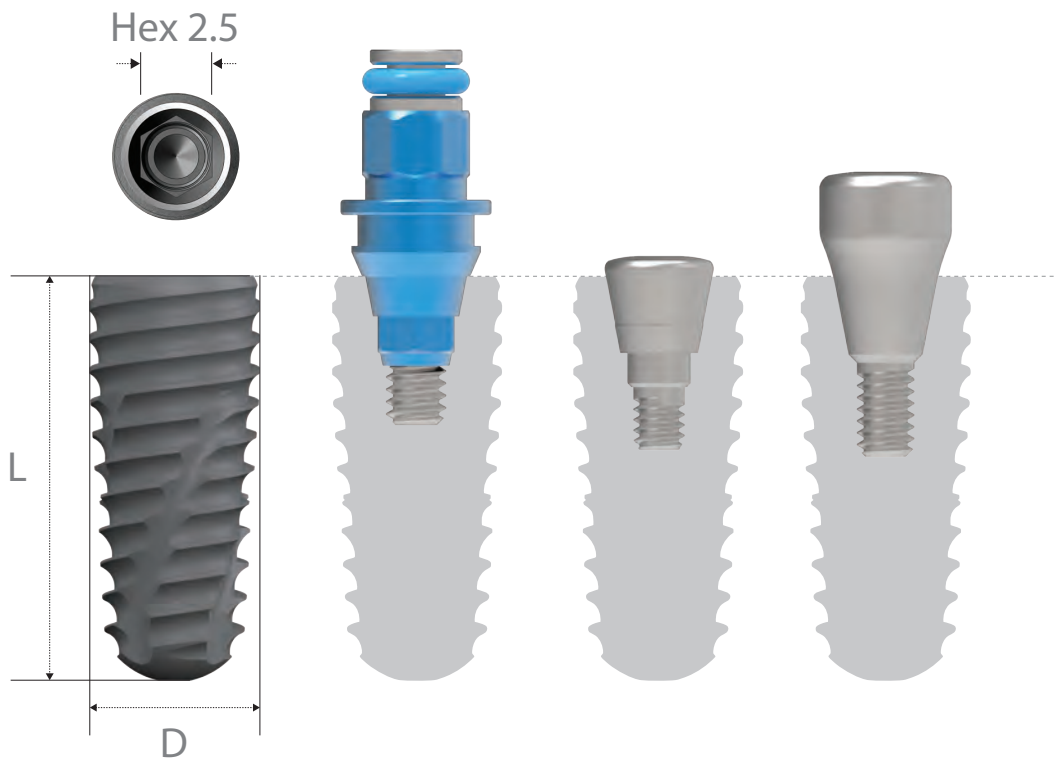

INNO Fixture Code

S	T	40	10	S	M	* Ex.)
Type Submerged	body Taper	Diameter Ø 4.0	Length 10 mm	Surface Treatment SLA	Mount No-Mount	SLA No-Mount ST4010SM

S	T	40	10	S		* Ex.)
Type Submerged	body Taper	Diameter Ø 4.0	Length 10 mm	Surface Treatment SLA	Mount Pre-Mount	SLA Pre-Mount ST4010S

No-Mount > 포장단위 : 1 Fixture + 1 Cover Screw

Diameter (실직경) **Ø3.5 (Ø3.7)**

Length

7	-
8	ST3508SM
10	ST3510SM
12	ST3512SM
14	ST3514SM

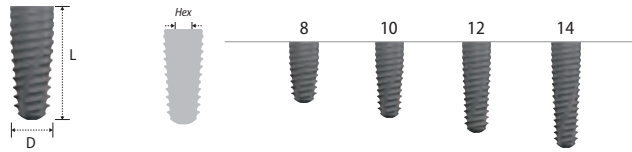

Diameter (실직경) **Ø4.0 (Ø4.2)**

Length

7	ST4007SM
8	ST4008SM
10	ST4010SM
12	ST4012SM
14	ST4014SM
16	ST4016SM
18	ST4018SM

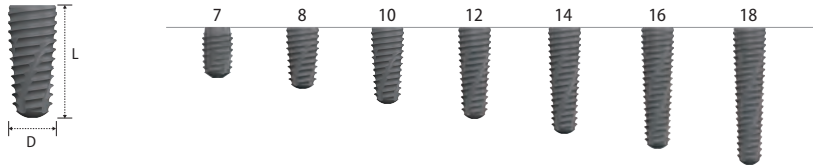

Diameter (실직경) **Ø4.5 (Ø4.6)**

Length

7	ST4507SM
8	ST4508SM
10	ST4510SM
12	ST4512SM
14	ST4514SM
16	ST4516SM
18	ST4518SM

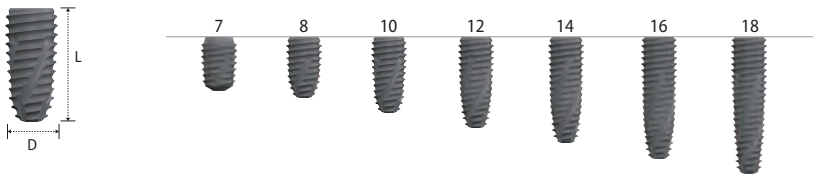

Diameter (실직경) **Ø5.0 (Ø5.1)**

Length

7	ST5007SM
8	ST5008SM
10	ST5010SM
12	ST5012SM
14	ST5014SM

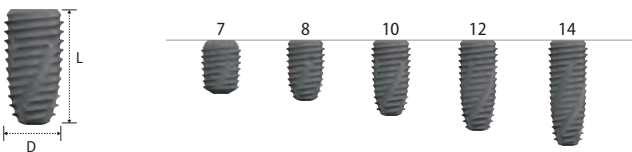

Diameter **Ø6.0**

Length (실제 길이)

7	ST6007SM
8 (7.5)	ST6008SM
10 (9.5)	ST6010SM
12 (11.5)	ST6012SM
14	-

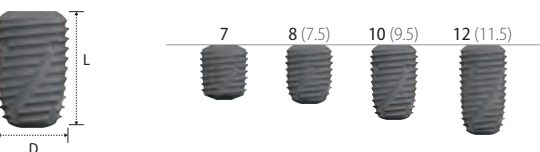

Pre-Mount > 포장단위 : 1 Fixture + 1 Cover Screw 1 + 1 Mount

Diameter (실직경) **Ø3.5 (Ø3.7)**

Length

7	-
8	ST3508S
10	ST3510S
12	ST3512S
14	ST3514S

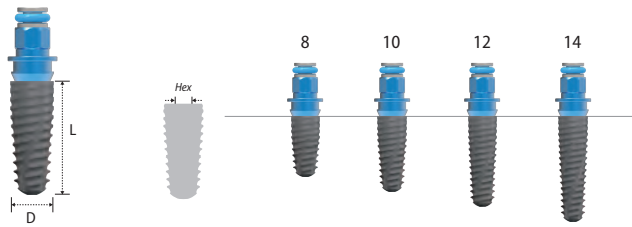

Diameter (실직경) **Ø4.0 (Ø4.2)**

Length

7	ST4007S
8	ST4008S
10	ST4010S
12	ST4012S
14	ST4014S
16	ST4016S
18	ST4018S

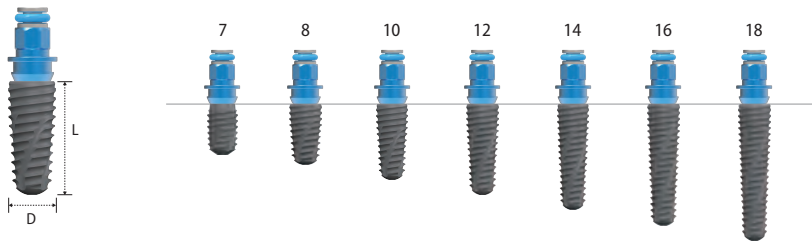

Diameter (실직경) **Ø4.5 (Ø4.6)**

Length

7	ST4507S
8	ST4508S
10	ST4510S
12	ST4512S
14	ST4514S
16	ST4516S
18	ST4518S

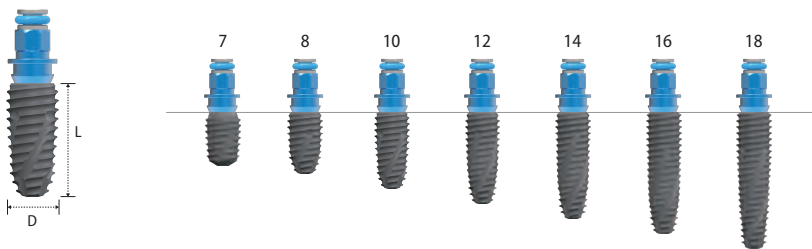

Diameter (실직경) **Ø5.0 (Ø5.1)**

Length

7	ST5007S
8	ST5008S
10	ST5010S
12	ST5012S
14	ST5014S

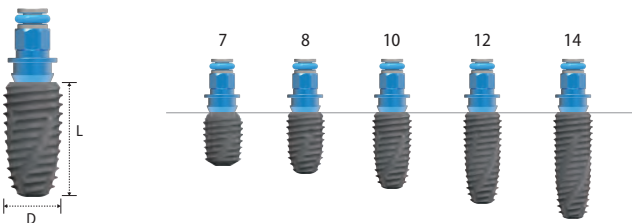

Diameter **Ø6.0**

Length (실제 길이)

7	ST6007S
8 (7.5)	ST6008S
10 (9.5)	ST6010S
12 (11.5)	ST6012S
14	-

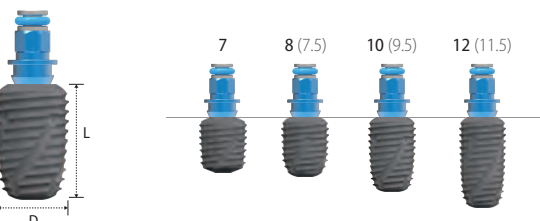

INNO X Implant



Submerged Fixture
Surface Treatment: **SLA-SH**

- > Interchangeable with hexagonal morse tapered fixture
- > Internal hex connection (Taper 11°/ Hex 2.5)
- > 2 spiral round cutting edge & 2 Flat cutting edge

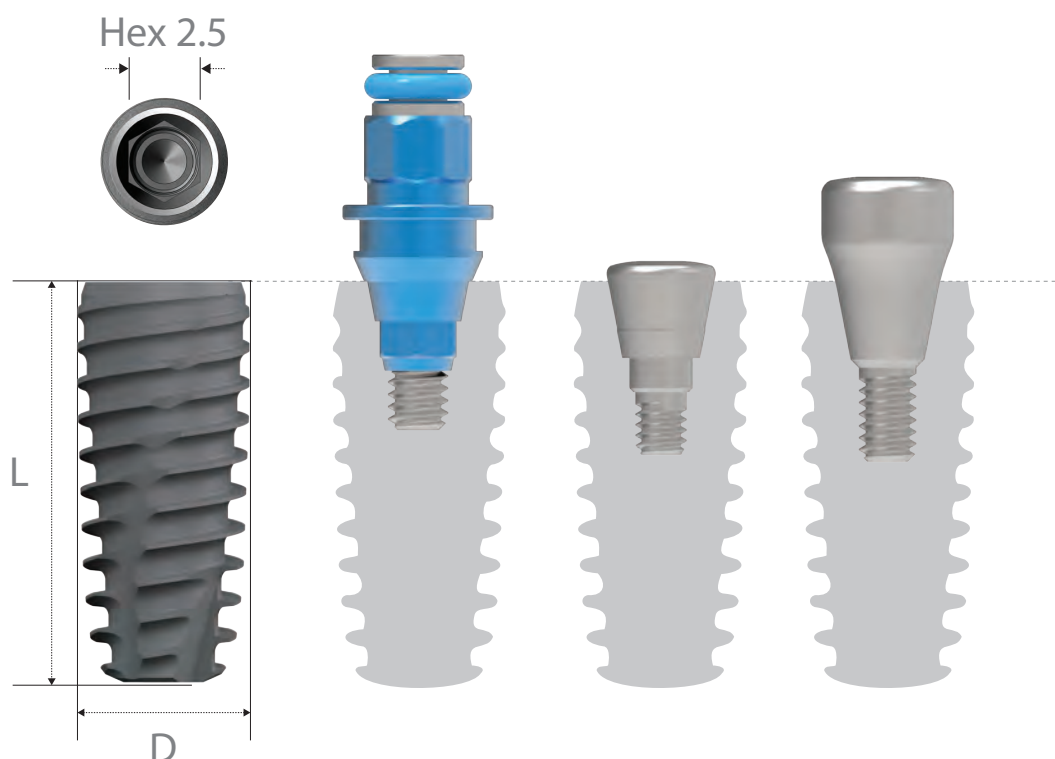

INNO Fixture Code

S	2	T	40	10	S	M	*Ex.)
Type Submerged	Type X	body Taper	Diameter Ø4.0	Length 10mm	Surface Treatment SLA	Mount No-Mount	SLA No-Mount S2T4010SM

S	2	T	40	10	S		*Ex.)
Type Submerged	Type X	body Taper	Diameter Ø4.0	Length 10mm	Surface Treatment SLA	Mount Pre-Mount	SLA Pre-Mount S2T4010S

No-Mount > 포장단위 : 1 Fixture + 1 Cover Screw

Diameter (실직경) **Ø3.5 (Ø3.8)**

Length

7	-
8	S2T3508SM
10	S2T3510SM
12	S2T3512SM
14	S2T3514SM

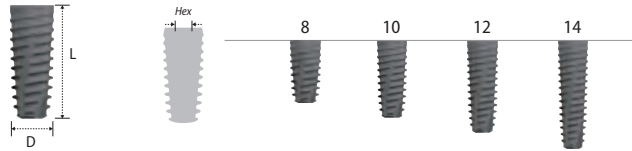

Diameter (실직경) **Ø4.0 (Ø4.3)**

Length

7	S2T4007SM
8	S2T4008SM
10	S2T4010SM
12	S2T4012SM
14	S2T4014SM
16	S2T4016SM
18	S2T4018SM

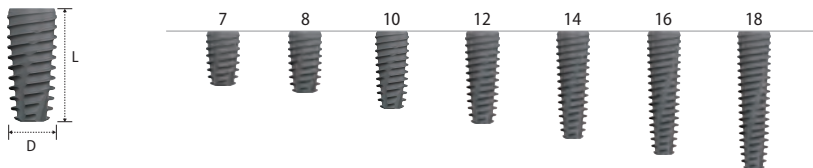

Diameter (실직경) **Ø4.5 (Ø4.8)**

Length

7	S2T4507SM
8	S2T4508SM
10	S2T4510SM
12	S2T4512SM
14	S2T4514SM
16	S2T4516SM
18	S2T4518SM

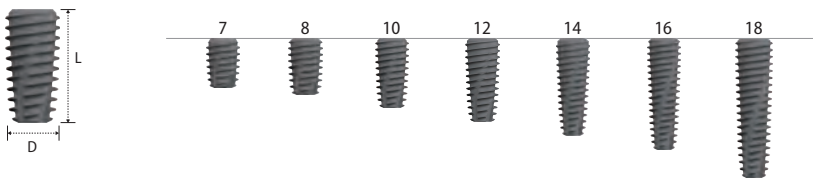

Diameter (실직경) **Ø5.0 (Ø5.3)**

Length

7	S2T5007SM
8	S2T5008SM
10	S2T5010SM
12	S2T5012SM
14	S2T5014SM

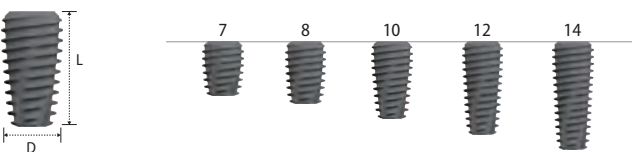

Diameter (실직경) **Ø6.0 (Ø6.3)**

Length (실제 길이)

7	S2T6007SM
8 (7.5)	S2T6008SM
10 (9.5)	S2T6010SM
12 (11.5)	S2T6012SM
14	-

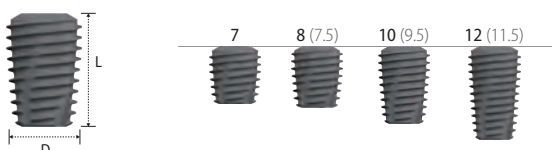

Pre-Mount > 포장단위 : 1 Fixture + 1 Cover Screw 1 + 1 Mount

Diameter (실직경) **Ø3.5 (Ø3.8)**

Length

7	-
8	S2T3508S
10	S2T3510S
12	S2T3512S
14	S2T3514S

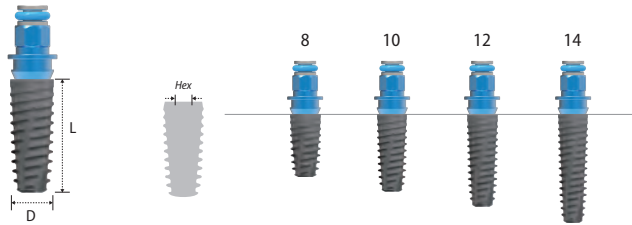

Diameter (실직경) **Ø4.0 (Ø4.3)**

Length

7	S2T4007S
8	S2T4008S
10	S2T4010S
12	S2T4012S
14	S2T4014S
16	S2T4016S
18	S2T4018S

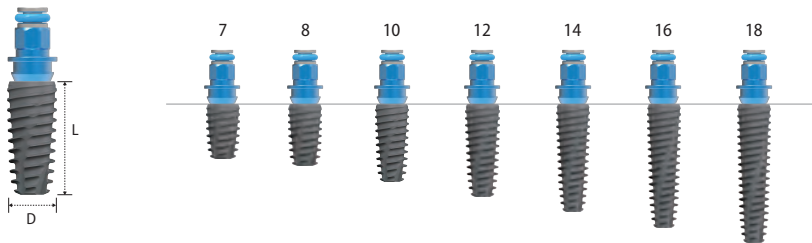

Diameter (실직경) **Ø4.5 (Ø4.8)**

Length

7	S2T4507S
8	S2T4508S
10	S2T4510S
12	S2T4512S
14	S2T4514S
16	S2T4516S
18	S2T4518S

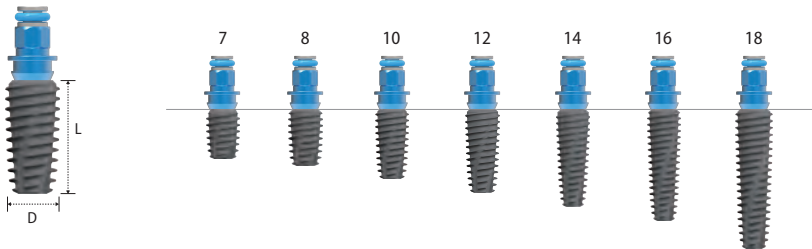

Diameter (실직경) **Ø5.0 (Ø5.3)**

Length

7	S2T5007S
8	S2T5008S
10	S2T5010S
12	S2T5012S
14	S2T5014S

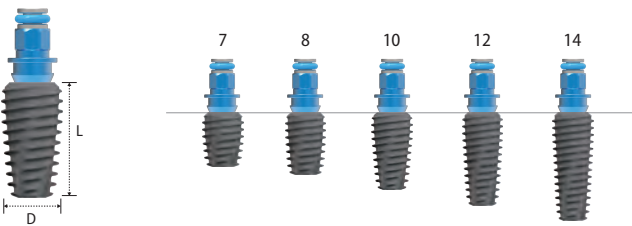

Diameter (실직경) **Ø6.0 (Ø6.3)**

Length (실제 길이)

7	S2T6007S
8 (7.5)	S2T6008S
10 (9.5)	S2T6010S
12 (11.5)	S2T6012S
14	-

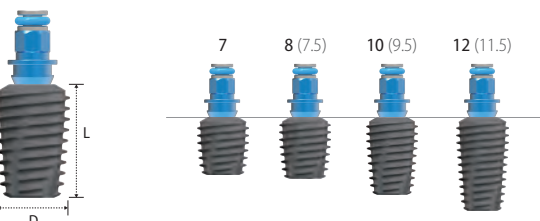

INNO V Implant



Submerged Fixture
Surface Treatment: **SLA-SH**

- > Interchangeable with hexagonal morse tapered fixture
- > Internal hex connection (Taper 11°/ Hex 2.5)
- > 2 spiral round cutting edge & 2 Flat cutting edge

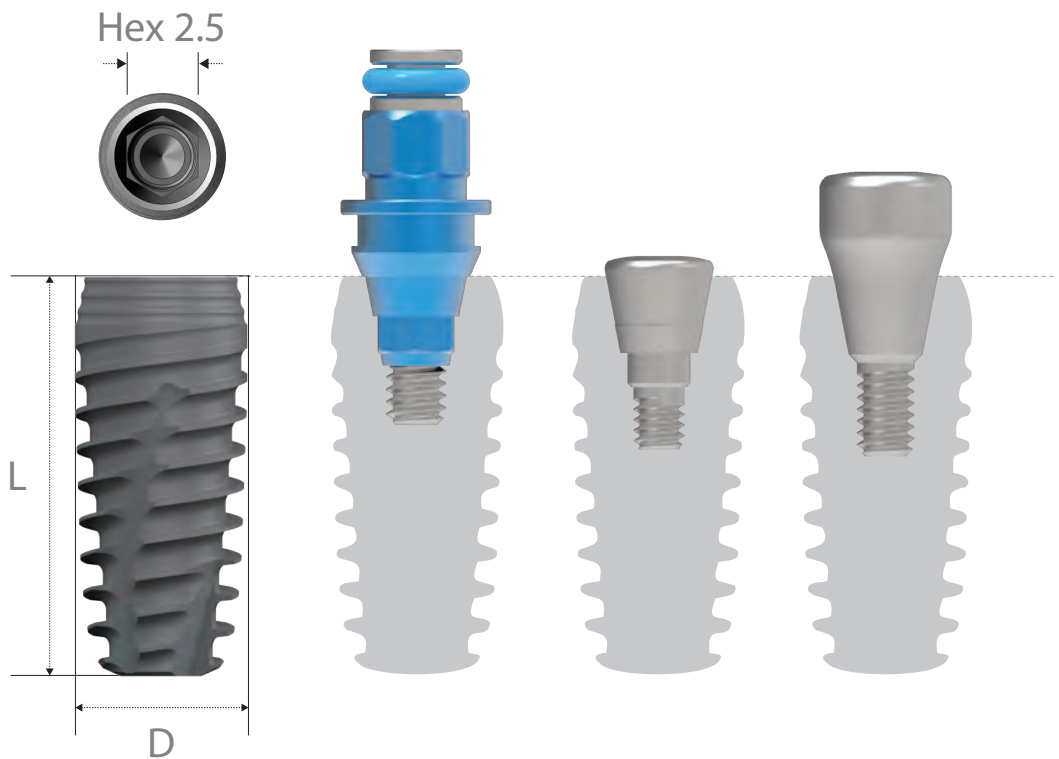

INNO Fixture Code

S	3	T	40	10	S	M	*Ex.)
Type Submerged	Type V	body Taper	Diameter Ø 4.0	Length 10mm	Surface Treatment SLA	Mount No-Mount	SLA No-Mount
							S3T4010SM

S	3	T	40	10	S		*Ex.)
Type Submerged	Type V	body Taper	Diameter Ø 4.0	Length 10mm	Surface Treatment SLA	Mount Pre-Mount	SLA Pre-Mount
							S3T4010S

No-Mount > 포장단위 : 1 Fixture + 1 Cover Screw

Diameter (실직경) **Ø3.5 (Ø3.8)**

Length

7	-
8	S3T3508SM
10	S3T3510SM
12	S3T3512SM
14	S3T3514SM

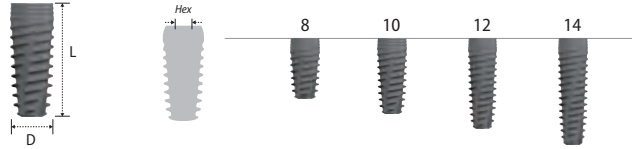

Diameter (실직경) **Ø4.0 (Ø4.3)**

Length

7	S3T4007SM
8	S3T4008SM
10	S3T4010SM
12	S3T4012SM
14	S3T4014SM
16	S3T4016SM
18	S3T4018SM

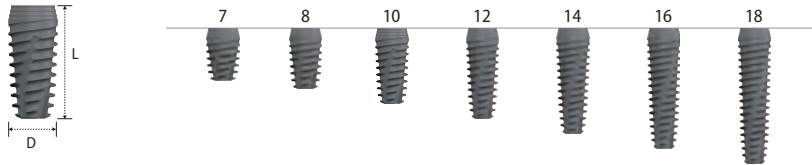

Diameter (실직경) **Ø4.5 (Ø4.8)**

Length

7	S3T4507SM
8	S3T4508SM
10	S3T4510SM
12	S3T4512SM
14	S3T4514SM
16	S3T4516SM
18	S3T4518SM

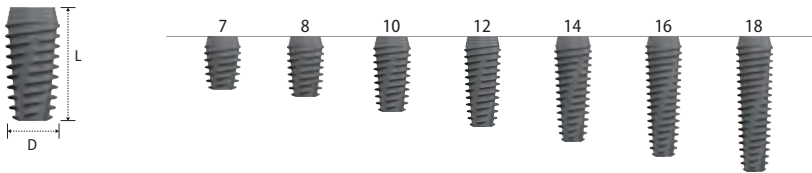

Diameter (실직경) **Ø5.0 (Ø5.3)**

Length

7	S3T5007SM
8	S3T5008SM
10	S3T5010SM
12	S3T5012SM
14	S3T5014SM

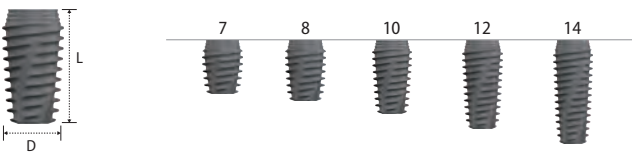

Diameter (실직경) **Ø6.0 (Ø6.3)**

Length (실제 길이)

7	S3T6007SM
8 (7.5)	S3T6008SM
10 (9.5)	S3T6010SM
12 (11.5)	S3T6012SM
14	-

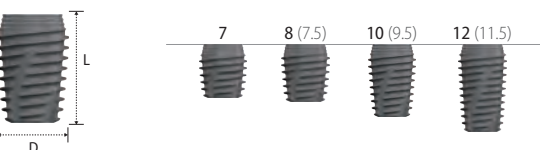

Pre-Mount > 포장단위 : 1 Fixture + 1 Cover Screw 1 + 1 Mount

Diameter (실직경) **Ø3.5 (Ø3.8)**

Length

7	-
8	S3T3508S
10	S3T3510S
12	S3T3512S
14	S3T3514S

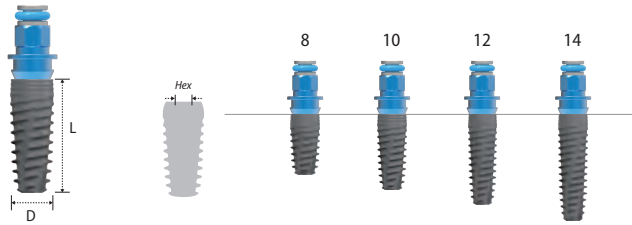

Diameter (실직경) **Ø4.0 (Ø4.3)**

Length

7	S3T4007S
8	S3T4008S
10	S3T4010S
12	S3T4012S
14	S3T4014S
16	S3T4016S
18	S3T4018S

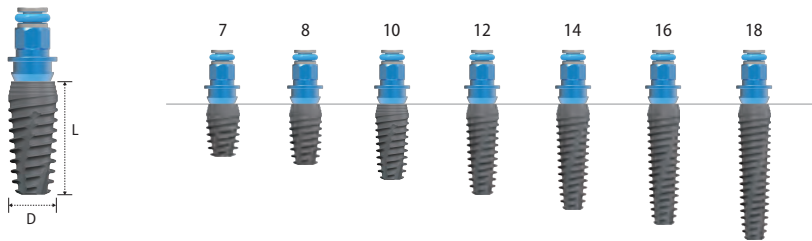

Diameter (실직경) **Ø4.5 (Ø4.8)**

Length

7	S3T4507S
8	S3T4508S
10	S3T4510S
12	S3T4512S
14	S3T4514S
16	S3T4516S
18	S3T4518S

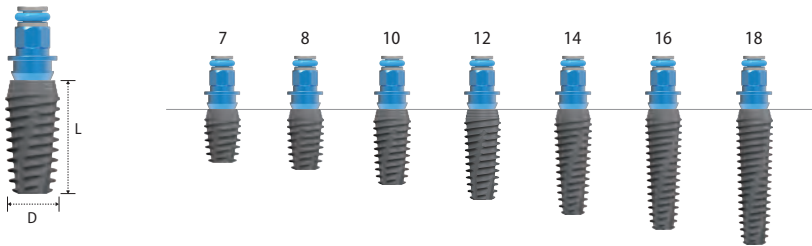

Diameter (실직경) **Ø5.0 (Ø5.3)**

Length

7	S3T5007S
8	S3T5008S
10	S3T5010S
12	S3T5012S
14	S3T5014S

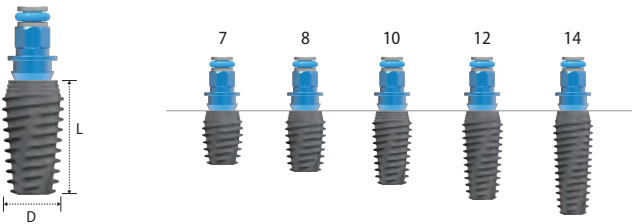

Diameter (실직경) **Ø6.0 (Ø6.3)**

Length (실제 길이)

7	S3T6007S
8 (7.5)	S3T6008S
10 (9.5)	S3T6010S
12 (11.5)	S3T6012S
14	-

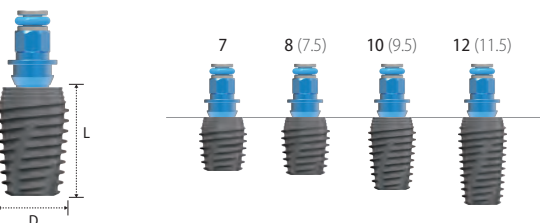

INNO Submerged Short Implant



Submerged Short Fixture
Surface Treatment: **SLA-SH**

- > Interchangeable with Hexagonal Morse Tapered Fixture.
- > Internal hex connection (Taper 11°/ Hex 2.5).

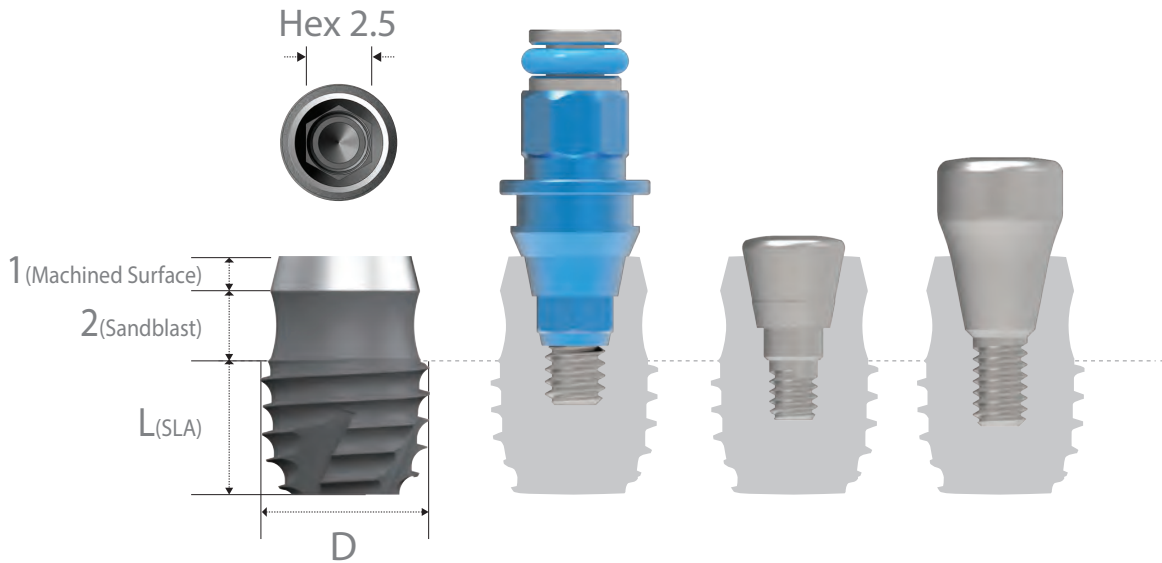

Pre-Mount > 포장단위 : 1 Fixture + 1 Cover Screw + 1 Mount.

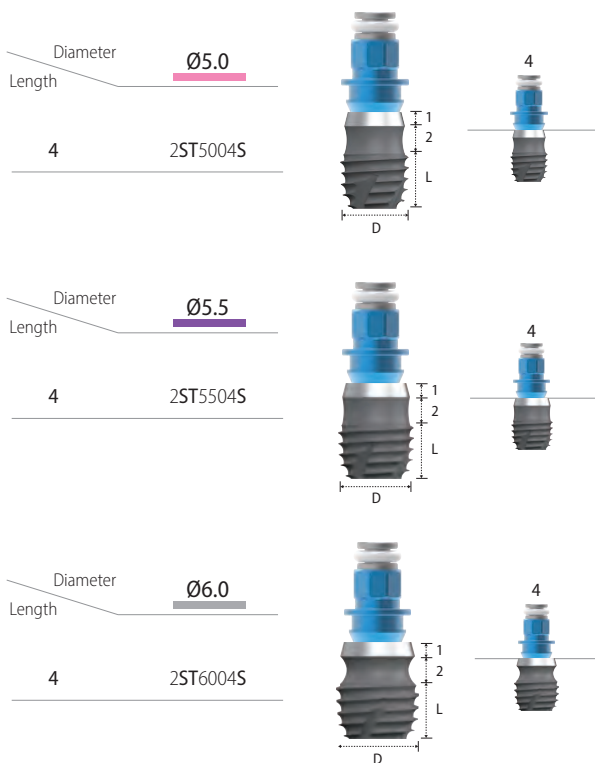

Fixture Mount

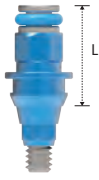

Length	5.4
2SMHR001	

- > 포장단위 : 1 Mount + 1 Mount Screw
- > Hex Driver를 사용하여 체결
- > 권장 체결 토크 : 10Ncm

Cover Screw



Diameter / Length	Ø3.37	Ø3.75	Ø4.13
3	2SCS000		
4.2		* 2SCS001	
5.2			* 2SCS002

- > 포장단위 : 1 Cover Screw *Extra Product
- > Fixture 식립 후 Fixture connection 보호
- > 깊게 식립 시 Long Cover Screw 사용
- > Hex Driver를 사용하여 체결
- > 권장 체결 토크 : 10Ncm

Healing Abutment

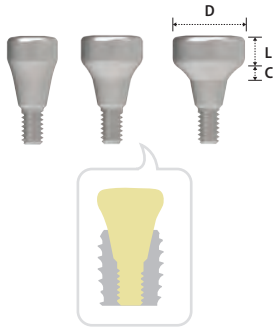

Diameter	Ø4.0		Ø4.5		Ø5.0		Ø5.5	
Length / Cuff	1	2	1	2	1	2	1	2
1	2HS4011		2HS4511		2HS5011		2HS5511	
2		2HS4022		2HS4522		2HS5022		2HS5522
3		2HS4032		2HS4532		2HS5032		2HS5532
4		2HS4042		2HS4542		2HS5042		2HS5542
5		2HS4052		2HS4552		2HS5052		2HS5552
6		2HS4062		2HS4562		2HS5062		2HS5562
7		2HS4072		2HS4572		2HS5072		2HS5572

Diameter	Ø6.0		Ø6.5		Ø7.0		Ø7.5/Ø8.5/Ø9.5	
Length / Cuff	1	2	1	2	1	2	2	
1	2HS6011		2HS6511		2HS7011		Cuff 3	
2		2HS6022		2HS6522		2HS7022		
3		2HS6032		2HS6532		2HS7032		2HS7532
4		2HS6042		2HS6542		2HS7042		2HS8532
5		2HS6052		2HS6552		2HS7052		2HS9532
6		2HS6062		2HS6562		2HS7062		
7		2HS6072		2HS6572		2HS7072		

- > 포장단위 : 1 Healing Abutment
- > 치유기간 동안 Fixture에 체결하여 치은 형태 형성
- > 치은 높이 및 사용 Abutment에 따라 선택 사용
- > Hex Driver를 사용하여 체결
- > 권장 체결 토크 : 10Ncm

Volume-up Healing Abutment

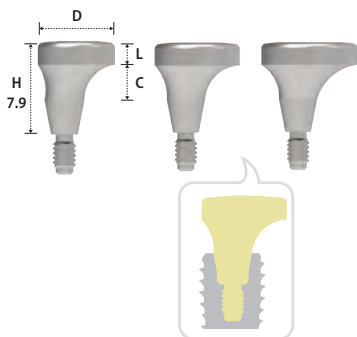

Diameter	Ø6.5	Ø7.5	Ø8.5
Length / Cuff	2	2	2
3	VUHN6532	VUHN7532	VUHN8532

- > 포장단위 : 1 Healing Abutment(Inbuilt Abutment Screw)
- > Off-center 형태로 협측 치조골 폭경 수축을 방지하고 치은의 불용유지와 음식물 저류를 방지
- > COWELL BMP와 함께 사용 시 효과 극대화
- > Volume-up Guide System과 함께 사용 권장
- > 치은 높이에 따라 선택 사용
- > Hex Driver를 사용하여 체결
- > 권장 체결 토크 : 10Ncm



Prosthetic Procedure I

Components Selection Guide for Cemented and UCLA Abutment

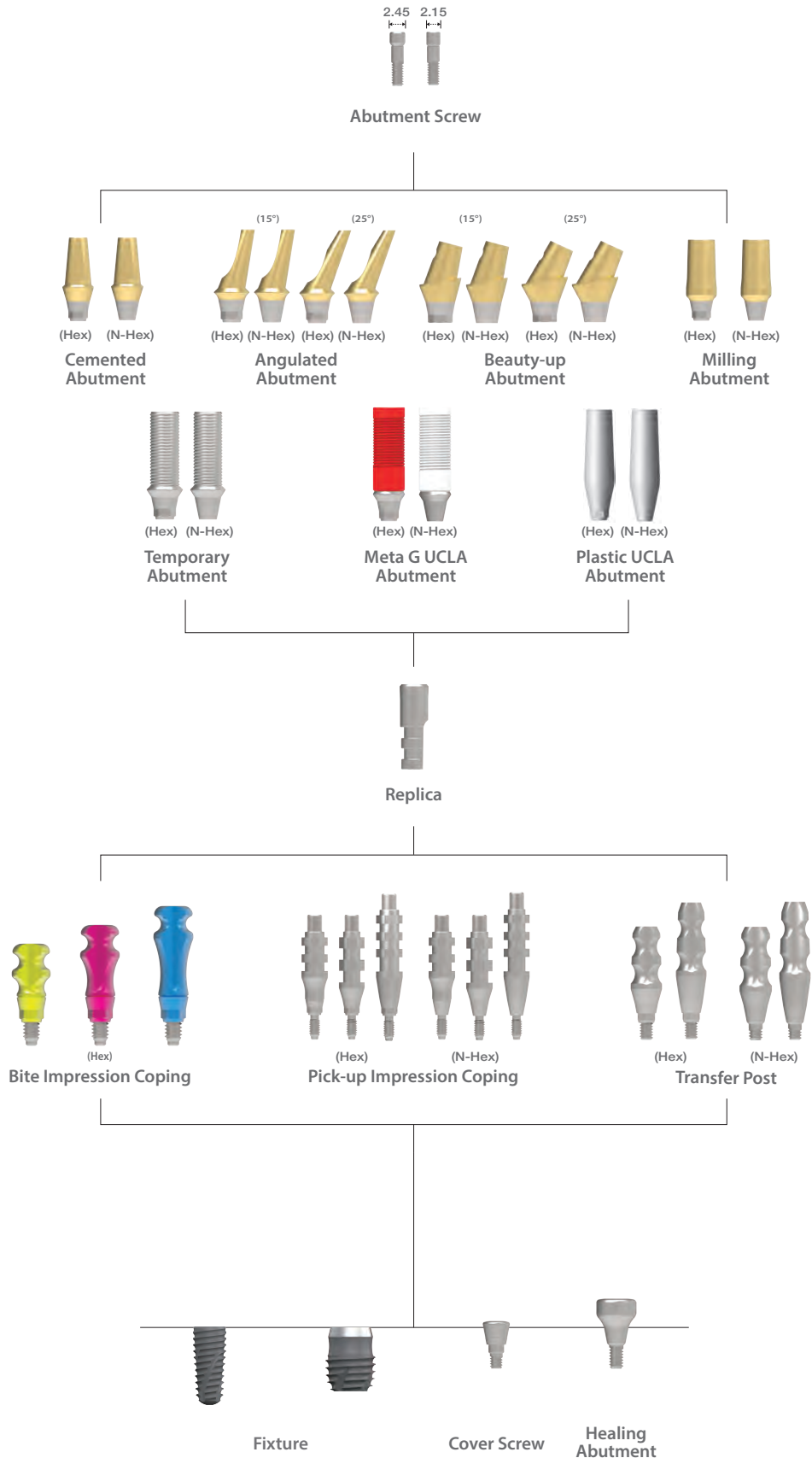

Cemented Abutment

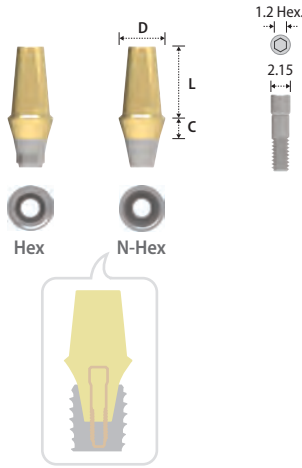

Type	Hex														
Diameter	Ø4.5			Ø5.0			Ø5.5			Ø6.0			Ø6.5		
Length / Cuff	4	5.5	7	4	5.5	7	4	5.5	7	4	5.5	7	4	5.5	7
1	2SCH 4514	2SCH 4515	2SCH 4517	2SCH 5014	2SCH 5015	2SCH 5017	2SCH 5514	2SCH 5515	2SCH 5517	2SCH 6014	2SCH 6015	2SCH 6017	2SCH 6514	2SCH 6515	2SCH 6517
2	2SCH 4524	2SCH 4525	2SCH 4527	2SCH 5024	2SCH 5025	2SCH 5027	2SCH 5524	2SCH 5525	2SCH 5527	2SCH 6024	2SCH 6025	2SCH 6027	2SCH 6524	2SCH 6525	2SCH 6527
3	2SCH 4534	2SCH 4535	2SCH 4537	2SCH 5034	2SCH 5035	2SCH 5037	2SCH 5534	2SCH 5535	2SCH 5537	2SCH 6034	2SCH 6035	2SCH 6037	2SCH 6534	2SCH 6535	2SCH 6537
4	2SCH 4544	2SCH 4545	2SCH 4547	2SCH 5044	2SCH 5045	2SCH 5047	2SCH 5544	2SCH 5545	2SCH 5547	2SCH 6044	2SCH 6045	2SCH 6047	2SCH 6544	2SCH 6545	2SCH 6547
5	2SCH 4554	2SCH 4555	2SCH 4557	2SCH 5054	2SCH 5055	2SCH 5057	2SCH 5554	2SCH 5555	2SCH 5557	2SCH 6054	2SCH 6055	2SCH 6057	2SCH 6554	2SCH 6555	2SCH 6557

Type	N-Hex														
Diameter	Ø4.5			Ø5.0			Ø5.5			Ø6.0			Ø6.5		
Length / Cuff	4	5.5	7	4	5.5	7	4	5.5	7	4	5.5	7	4	5.5	7
1	2SCN 4514	2SCN 4515	2SCN 4517	2SCN 5014	2SCN 5015	2SCN 5017	2SCN 5514	2SCN 5515	2SCN 5517	2SCN 6014	2SCN 6015	2SCN 6017	2SCN 6514	2SCN 6515	2SCN 6517
2	2SCN 4524	2SCN 4525	2SCN 4527	2SCN 5024	2SCN 5025	2SCN 5027	2SCN 5524	2SCN 5525	2SCN 5527	2SCN 6024	2SCN 6025	2SCN 6027	2SCN 6524	2SCN 6525	2SCN 6527
3	2SCN 4534	2SCN 4535	2SCN 4537	2SCN 5034	2SCN 5035	2SCN 5037	2SCN 5534	2SCN 5535	2SCN 5537	2SCN 6034	2SCN 6035	2SCN 6037	2SCN 6534	2SCN 6535	2SCN 6537
4	2SCN 4544	2SCN 4545	2SCN 4547	2SCN 5044	2SCN 5045	2SCN 5047	2SCN 5544	2SCN 5545	2SCN 5547	2SCN 6044	2SCN 6045	2SCN 6047	2SCN 6544	2SCN 6545	2SCN 6547
5	2SCN 4554	2SCN 4555	2SCN 4557	2SCN 5054	2SCN 5055	2SCN 5057	2SCN 5554	2SCN 5555	2SCN 5557	2SCN 6054	2SCN 6055	2SCN 6057	2SCN 6554	2SCN 6555	2SCN 6557

- > 포장단위 : 1 Cemented Abutment + 1 Abutment Screw(2SSHR200)
- > CRP 및 SCRП 유지형 보철 제작
- > 회전방지 단면 부여
- > 심미성을 위한 Gold coloring
- > Scanbody 사용 시 Digital work 가능
- > 3shape 및 Exocad용 라이브러리 제공
- > Hex Driver와 Torque Wrench를 사용하여 체결
- > 권장 체결 토크 : 30Ncm
- > Fixture level impression
- > Absolute Impression Cap 사용시 Abutment level impression 가능

Angulated Abutment

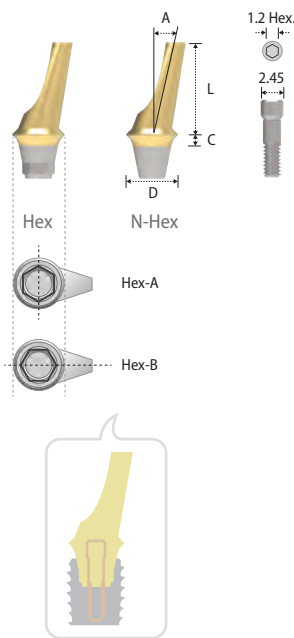

Type	Hex-A				Hex-B			
Diameter(Angle)	Ø4.5(15°)	Ø4.5(25°)	Ø5.5(15°)	Ø5.5(25°)	Ø4.5(15°)	Ø4.5(25°)	Ø5.5(15°)	Ø5.5(25°)
Length / Cuff	8	8	8	8	8	8	8	8
1	2SAH45151	2SAH45251	2SAH55151	2SAH55251	2SAH45151B	2SAH45251B	2SAH55151B	2SAH55251B
2	2SAH45152	2SAH45252	2SAH55152	2SAH55252	2SAH45152B	2SAH45252B	2SAH55152B	2SAH55252B
3	2SAH45153	2SAH45253	2SAH55153	2SAH55253	2SAH45153B	2SAH45253B	2SAH55153B	2SAH55253B
4	2SAH45154	2SAH45254	2SAH55154	2SAH55254	2SAH45154B	2SAH45254B	2SAH55154B	2SAH55254B

Type	N-Hex			
Diameter(Angle)	Ø4.5(15°)	Ø4.5(25°)	Ø5.5(15°)	Ø5.5(25°)
Length / Cuff	8	8	8	8
1	2SAN45151	2SAN45251	2SAN55151	2SAN55251
2	2SAN45152	2SAN45252	2SAN55152	2SAN55252
3	2SAN45153	2SAN45253	2SAN55153	2SAN55253
4	2SAN45154	2SAN45254	2SAN55154	2SAN55254

- > 포장단위 : 1 Angulated Abutment + 1 Abutment Screw(2SSHR100)
- > CRP 유지형 보철 제작
- > Fixture path를 보상(최대 25°) 및 전치부에 사용
- > 심미성을 위한 Gold coloring
- > Scanbody 사용 시 Digital work 가능
- > 3shape 및 Exocad용 라이브러리 제공
- > Hex Driver와 Torque Wrench를 사용하여 체결
- > 권장 체결 토크 : 30Ncm
- > Fixture level impression

Beauty-up Abutment

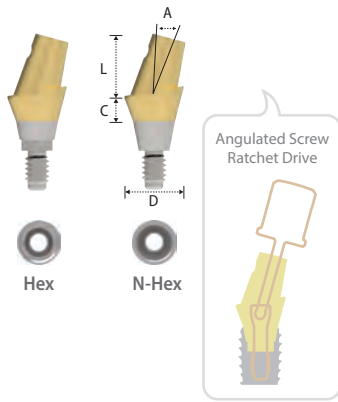

Type	Hex		N-Hex	
Diameter(Angle)	Ø3.8 (15°)		Ø3.8 (15°)	
Length	5		5	
Cuff	2		5	
	2SBH381525	2SBN381525	2SBH382525	2SBN382525

- > 포장단위 : 1 Angulated Abutment(Inbuilt Abutment Screw)
- > SCRП 유지형 보철 제작에 특화(CRP 가능)
- > 심미보철제작을 위한 Gingiva Line 적용
- > 경사진 Gingiva line과 Screw channel이 Lingual 방향으로 형성되어 심미보철 제작 가능
- > Scanbody 사용 시 Digital work 가능
- > 3shape 및 Exocad용 라이브러리 제공
- > Torx A Driver와 Torque Wrench를 사용하여 체결
- > 권장 체결 토크 : 30Ncm
- > Fixture level impression

* Torx A Ratchet Driver

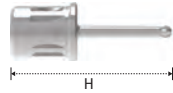

Height	Type	Ratchet
24(Short)		KRBUD15
29(Long)		KRBUD20

- > Torx A Driver와 Angulated screw channel용 Torx 구조가 있는 Abutment Screw의 접촉면적이 넓어 Internal slip이나 파절 염려가 적음
- > 25°기준 최대 토크 50Ncm

Milling Abutment

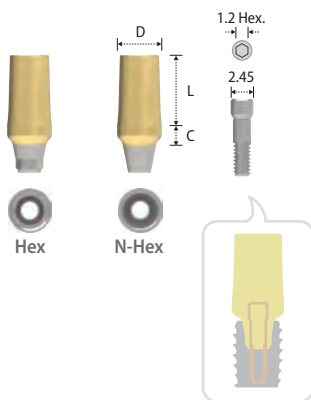

Type	Hex			N-Hex		
Diameter	Ø4.5	Ø5.5	Ø6.5	Ø4.5	Ø5.5	Ø6.5
Length	7.1			7.1		
Cuff	2			4		
	2SMH4527	2SMH5527	2SMH6527	2SMN4527	2SMN5527	2SMN6527
	2SMH4547	2SMH5547	2SMH6547	2SMN4547	2SMN5547	2SMN6547

- > 포장단위 : 1 Angulated Abutment + 1 Abutment Screw(2SSHR100)
- > CRP 및 SCRП 유지형 보철 제작
- > Abutment path 수정이나 보철 Margin부 Customizing이 필요한 경우에 사용
- > 심미성을 위한 Gold coloring
- > Hex Driver와 Torque Wrench를 사용하여 체결
- > 권장 체결 토크 : 30Ncm
- > Fixture level impression

Temporary Abutment

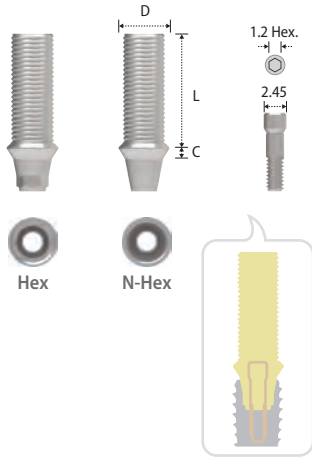

Type	Hex	N-Hex
Diameter	Ø4.5	Ø4.5
Length Cuff	10	10
1	2STHA45	2STNA45

- > 포장단위 : 1 Temporary Abutment + 1 Abutment Screw(2SSHR100)
- > CRP, SRP 및 SCRП 유지형 임시 보철 제작
- > Resin 탈락 방지를 위한 Groove 부여
- > Hex Driver와 Torque Wrench를 사용하여 체결
- > 권장 체결 토크 : 30Ncm
- > Fixture level impression

Meta G UCLA Abutment

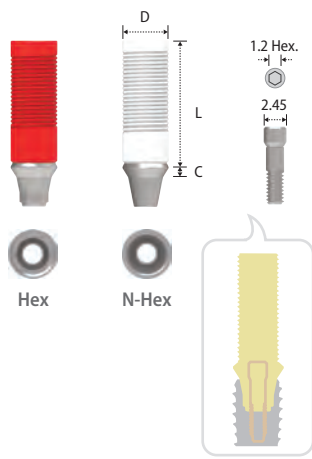

Type	Hex	N-Hex
Diameter	Ø4.5	Ø4.5
Length Cuff	12.4	12.4
1	2SGH45N	2SGN45N
2	2SGH452N	2SGN452N
3	2SGH453N	2SGN453N

- > 포장단위 : 1 Meta G UCLA Abutment + 1 Abutment Screw(2SSHR100)
- > CRP, SRP 및 SCRП 유지형 보철 제작
- > Path 조정, 심미 등을 위한 Customizing이 필요한 경우에 사용
- > 비귀금속 합금을 사용하여 Casting하여 보철물 제작
- > Metal base로 Connection부의 정밀도가 높음
- > Hex Driver와 Torque Wrench를 사용하여 체결
- > 권장 체결 토크 : 30Ncm
- > Fixture level impression

Plastic UCLA Abutment

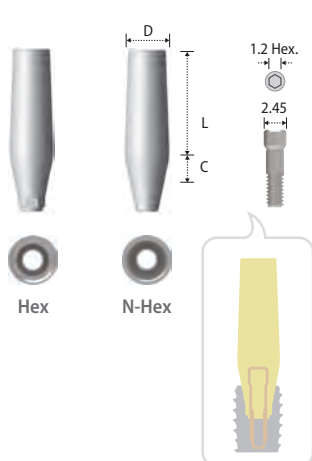

Type	Hex		N-Hex	
Diameter	Ø4.5	Ø5.5	Ø4.5	Ø5.5
Length Cuff	11	11	11	11
3	2SPHR001	2SPHW001	2SPNR001	2SPNW001

- > 포장단위 : 1 Plastic UCLA Abutment + 1 Abutment Screw(2SSHR200)
- > Meta G UCLA Abutment와 같은 용도로 사용하나 Connection부의 정밀도가 떨어짐
- > 권장 체결 토크 : Casting 전 20Ncm이하, Casting 후 30Ncm
- > Fixture level impression

Abutment Screw

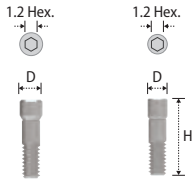

Diameter	Ø2.45	Ø2.15
Height	2SSHR100	2SSHR200

- > 포장단위 : 1 Abutment Screw
- > 2SSHR100 : Angulated, Milling, Temporary, Meta G UCLA 및 Plastic UCLA Abutment
- > 2SSHR200 : Cemented Abutment
- > Hex Driver와 Torque Wrench를 사용하여 체결

Replica



Diameter	Ø4
Height	2SRHR001

- > 포장단위 : 1 Replica
- > Fixture analog로 작업모형 상에 Fixture 형상 구현

Bite Impression Coping



Type	Hex(Short)	Hex(Long)	Hex(X-Long)
Diameter	Ø4.5	Ø4.5	Ø4.5
Length / Cuff	2	4	6
	4.0 2SBIC45S	2SBIC45L	2SBIC45X

- > 포장단위 : 1 Bite Impression Coping (Inbuilt Guide Pin)
- > Bite tray 사용
- > Bite와 Impression 동시 채득 가능
- > Hex Driver를 사용하여 체결
- > 권장 체결 토크 : 12~15Ncm
- > Fixture level impression

Pick-up Impression Coping

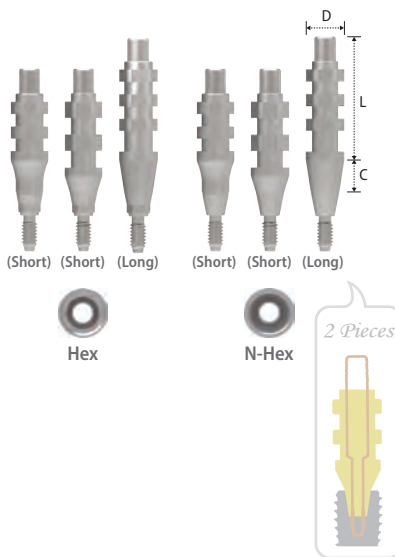

Type	Hex			N-Hex		
Diameter / Length / Cuff	Ø4.5	Ø5.5	Ø6.5	Ø4.5	Ø5.5	Ø6.5
12 (Short) / 4	2SIH454S	2SIH554S	2SIH654S	2SIN454S	2SIN554S	2SIN654S
14 (Short) / 2	2SIH45S	2SIH55S	2SIH65S	2SIN45S	2SIN55S	2SIN65S
16 (Long) / 4	2SIH45L	2SIH55L	2SIH65L	2SIN45L	2SIN55L	2SIN65L

- > 포장단위 : 1 Pick-up Impression Coping + 1 Guide Pin(2SISR001SS / 2SISR001SL)
- > Open tray 사용 (Custom tray)
- > Hex Driver를 사용하여 체결
- > 권장 체결 토크 : 12~15Ncm
- > Fixture level impression

Transfer Post

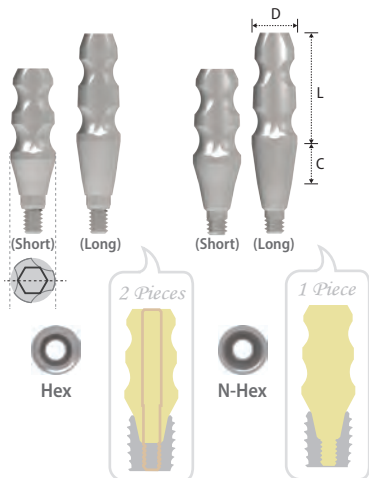

Type	Hex			N-Hex		
Diameter / Length / Cuff	Ø4.5	Ø5.5	Ø6.5	Ø4.5	Ø5.5	Ø6.5
9 (Short) / 2	2STH45S	2STH55S	2STH65S	2STN45S	2STN55S	2STN65S
11 (Long) / 4	2STH45L	2STH55L	2STH65L	2STN45L	2STN55L	2STN65L

- > 포장단위 : Hex- 1 Transfer Post + 1 Guide Pin(2STH001SS / 2STH001SL)
N-Hex- 1 Transfer Post(Solid type)
- > Closed tray 사용
- > Hex Driver를 사용하여 체결
- > 권장 체결 토크 : 12~15Ncm
- > Fixture level impression

Prosthetic Procedure II

Component Selection Guide for Multi S&A Abutment

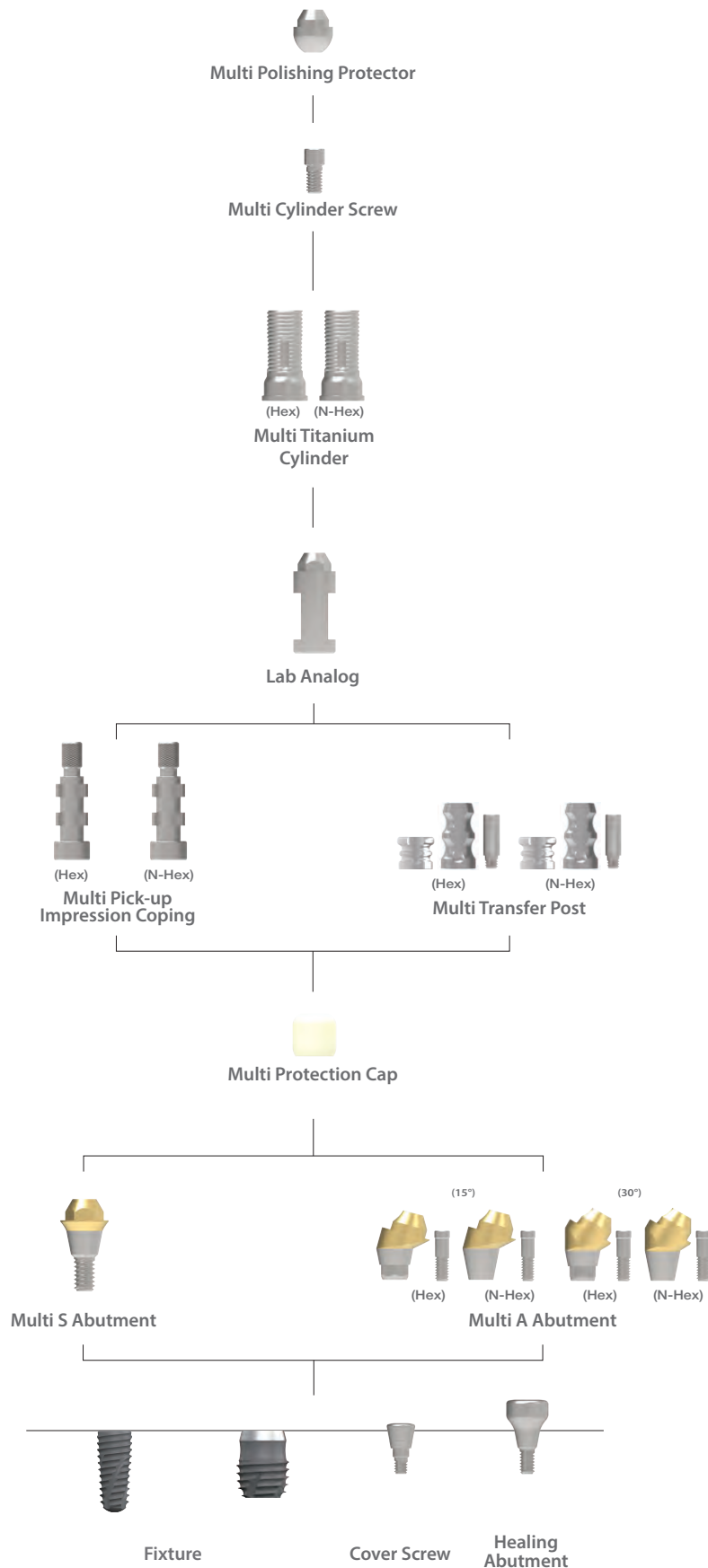

Multi S Abutment

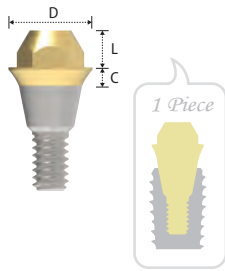

Diameter	Ø4.5	Ø5.5
Cuff Length	2	2
1	2SMS451	2SMS551
2	2SMS452	2SMS552
3	2SMS453	2SMS553
4	2SMS454	2SMS554
5	2SMS455	2SMS555

- > 포장단위 : 1 Multi S Abutment
- > SRP 유지형 보철 제작
- > Cylinder를 위한 Titanium-Base
- > Screw와 Abutment의 일체형 구조(Solid type)
- > 심미성을 위한 Gold coloring
- > Scanbody 사용 시 Digital work 가능
- > 3shape 및 Exocad용 라이브러리 제공
- > Multi S Holder를 사용하여 구강 내 Delivery
- > Multi S Driver와 Torque Wrench를 사용하여 체결
- > 권장 체결 토크 : 30Ncm
- > Abutment level impression

Multi A Abutment

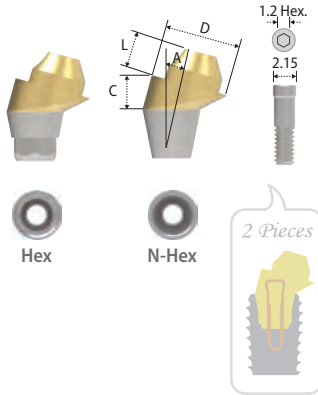

Type	Hex			
Diameter(Angle)	Ø4.5(15°)	Ø4.5(30°)	Ø5.5(15°)	Ø5.5(30°)
Cuff Length	2	2	2	2
2	● 2SMAH45152			
3	★ 2SMAH45153	● 2SMAH45303	★ 2SMAH55153	★ 2SMAH55303
4	★ 2SMAH45154	★ 2SMAH45304	★ 2SMAH55154	★ 2SMAH55304
5			★ 2SMAH55155	★ 2SMAH55305

Type	N-Hex			
Diameter(Angle)	Ø4.5(15°)	Ø4.5(30°)	Ø5.5(15°)	Ø5.5(30°)
Cuff Length	2	2	2	2
2	● 2SMAN45152			
3	★ 2SMAN45153	● 2SMAN45303	★ 2SMAN55153	★ 2SMAN55303
4	★ 2SMAN45154	★ 2SMAN45304	★ 2SMAN55154	★ 2SMAN55304
5			★ 2SMAN55155	★ 2SMAN55305

- > 포장단위 : 1 Multi A Abutment + Abutment Screw(2SSHR300: ★, 2SSHR400: ●)
- > SRP 유지형 보철 제작
- > Cylinder를 위한 Titanium-Base
- > Fixture path 보상(2개의 fixture 기준 최대 90°)
- > 심미성을 위한 Gold coloring
- > Scanbody 사용 시 Digital work 가능
- > 3shape 및 Exocad용 라이브러리 제공
- > Multi A Holder를 사용하여 구강 내 Delivery
- > Hex Driver와 Torque Wrench를 사용하여 체결
- > 권장 체결 토크 : 30Ncm
- > Abutment level impression

Abutment Screw

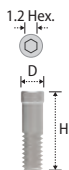

Height Diameter	7.5	6.5
2.15	★ 2SSHR300	● 2SSHR400

- > 포장단위 : 1 Abutment Screw
- > Multi A Abutment 체결 시 사용
- > Hex Driver와 Torque Wrench를 사용하여 체결

Multi Protection Cap

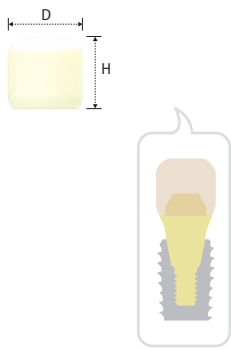

Multi S & A Abutment Diameter	Ø4.5	Ø5.5
Diameter Height	Ø5.2	Ø6.2
5	2SMPC45	2SMPC55

- > 포장단위 : 1 Multi Protection Cap
- > 치유기간 중 구강 내 Abutment를 보호하고 환자의 이물감을 최소화
- > Abutment의 보철 마진을 형성하기 위한 Gingival retraction에 사용
- > 임시 보철의 하부구조로 사용 가능
- > Hex Driver로 체결
- > 권장 체결 토크 : 5~10Ncm

Multi Pick-up Impression Coping

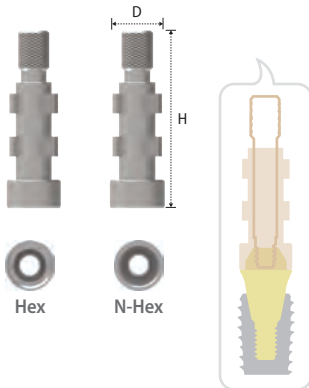

Type	Hex		N-Hex	
Multi S & A Abutment Diameter	Ø4.5	Ø5.5	Ø4.5	Ø5.5
Diameter Height	Ø4.65	Ø5.65	Ø4.65	Ø5.65
16	2SMIH45	2SMIH55	2SMIN45	2SMIN55

- > 포장단위 : 1 Multi Pick-up Impression Coping + 1 Guide Pin(2SMGP012)
- > Open tray 사용(Custom tray)
- > Hex Driver를 사용하여 체결
- > 권장 체결 토크 : 12~15Ncm
- > Abutment level impression

Multi Transfer Post

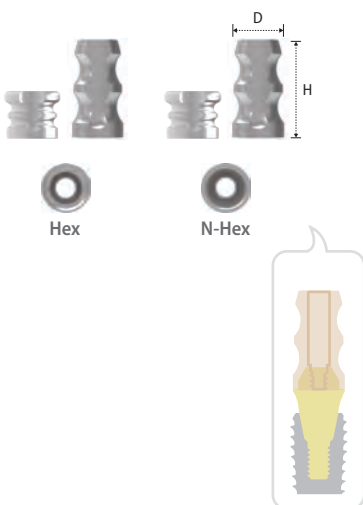

Type	Hex		N-Hex	
Multi S & A Abutment Diameter	Ø4.5	Ø5.5	Ø4.5	Ø5.5
Diameter Height	Ø4.5	Ø5.5	Ø4.5	Ø5.5
5	2SMTH455	2SMTH555	2SMTN455	2SMTN555
8.5	2SMTH45	2SMTH55	2SMTN45	2SMTN55

- > 포장단위 : 1 Multi Transfer Post + 1 Guide Pin(2SMTHS100)
- > Closed tray 사용
- > Hex Driver를 사용하여 체결
- > 권장 체결 토크 : 12~15Ncm
- > Abutment level impression

Multi Lab Analog



Multi S & A Abutment Diameter	Ø4.5	Ø5.5
Diameter	Ø4.5	Ø5.5
Length		
2	2SMA45	2SMA55

- > 포장단위 : 1 Multi Lab Analog
- > Abutment analog로 작업모형 상에 Abutment 형상 구현
- > Abutment의 직경에 따라 선택

Multi Titanium Cylinder

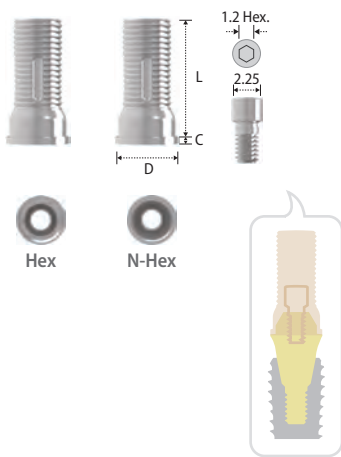

Type	Hex		N-Hex	
Multi S & A Abutment Diameter	Ø4.5	Ø5.5	Ø4.5	Ø5.5
Diameter	Ø4.5	Ø5.5	Ø4.5	Ø5.5
Length				
Cuff	8.5	8.5	8.5	8.5
0.5	2STCH45	2STCH55	2STCN45	2STCN55

- > 포장단위 : 1 Multi Titanium Cylinder + 1 Multi Cylinder Screw(2SMCS100)
- > CRP, SRP 및 SCRP 유지형 보철 제작
- > 보철의 기계적 유지를 위한 Groove
- > Multi S Driver와 Torque Wrench를 사용하여 체결
- > 권장 체결 토크 : 20Ncm

Multi Cylinder Screw

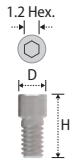

<i>Diameter</i>	Ø2.25
<i>Height</i>	5
2SMCS100	

- > 포장단위 : 1 Multi Cylinder Screw
- > Hex Driver와 Torque Wrench를 사용하여 체결

Multi Polishing Protector

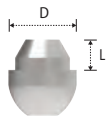

<i>Type</i>	Hex	
<i>Multi S & A Abutment Diameter</i>	Ø4.5	Ø5.5
<i>Diameter</i>	Ø4.5	Ø5.5
<i>Length</i>	2	2
2SMPP45		2SMPP55

- > 포장단위 : 1 Multi Polishing Protector
- > 가공 과정에서 Polishing 작업 시 Margin 보호

Multi Holder

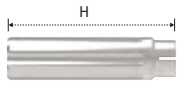

S Holder



Height	Type	Hand
20		KMHS01

- > 포장단위 : 1 Multi S Holder
- > 안정적으로 Multi S Abutment를 위치시키기 위하여 사용



A Holder

Height	Type	Hand
32		KMHA01

- > 포장단위 : 1 Multi A Holder
- > 안정적으로 Multi A Abutment를 위치시키기 위하여 사용



① Multi A Abutment에 Abutment Screw를 넣고 Multi A Holder와 연결한 뒤 Abutment와 Holder의 방향을 맞춤



② Multi A Holder의 손잡이를 잡고 구강 내 위치에 맞춰서 구부림



③ Fixture에 연결



④ Hex Driver와 Torque Wrench를 사용하여 Multi A Abutment를 조임

Multi S Machine Driver

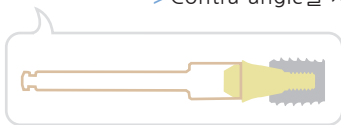
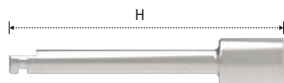

Height	Type	Machine
27.5		KMMSD21L

- > 포장단위 : 1 Multi S Machine Driver
- > Contra-angle를 사용하여 Multi S Abutment 체결

Multi S Ratchet Driver

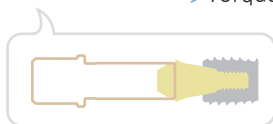
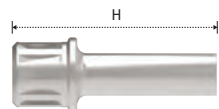

Height	Type	Ratchet
22		KRMSD15L

- > 포장단위 : 1 Multi S Ratchet Driver
- > Torque Wrench를 사용하여 Multi S Abutment 체결

Prosthetic Procedure III

Component Selection Guide for Absolute Abutment



Absolute Abutment

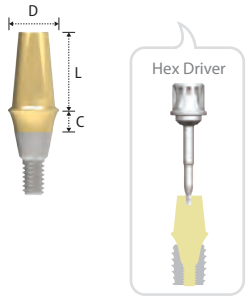

Diameter	Ø4.5			Ø5.5			Ø6.5		
Length / Cuff	4	5.5	7	4	5.5	7	4	5.5	7
1	2SAC4514	2SAC4515	2SAC4517	2SAC5514	2SAC5515	2SAC5517	2SAC6514	2SAC6515	2SAC6517
2	2SAC4524	2SAC4525	2SAC4527	2SAC5524	2SAC5525	2SAC5527	2SAC6524	2SAC6525	2SAC6527
3	2SAC4534	2SAC4535	2SAC4537	2SAC5534	2SAC5535	2SAC5537	2SAC6534	2SAC6535	2SAC6537
4	2SAC4544	2SAC4545	2SAC4547	2SAC5544	2SAC5545	2SAC5547	2SAC6544	2SAC6545	2SAC6547
5	2SAC4554	2SAC4555	2SAC4557	2SAC5554	2SAC5555	2SAC5557	2SAC6554	2SAC6555	2SAC6557

- > 포장단위 : 1 Absolute Abutment(Solid type) + 1 Protection Cap
- > CRP 유지형 보철 제작
- > 회전방지 단면 부여
- > 심미성을 위한 Gold coloring
- > Absolute Ratchet Driver(Hex Driver 체결 가능)와 Torque Wrench를 사용하여 체결
- > 권장 체결 토크 : 30Ncm
- > Abutment level impression

Absolute Ratchet Driver

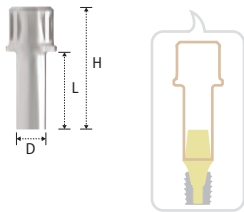

Diameter	Ø4.6		Ø5.6		Ø6.6	
Length / Height	12	19	12	19	12	19
19	KRAD4512S		KRAD5512S		KRAD6512S	
26		KRAD4519L		KRAD5519L		KRAD6519L

- > 포장단위 : 1 Absolute Ratchet Driver
- > Torque Wrench를 사용하여 Absolute Abutment 체결

Absolute Protection Cap

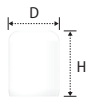

Absolute Abutment Diameter	Ø4.5	Ø5.5	Ø6.5
Diameter / Height	Ø5.0	Ø6.0	Ø7.0
6	2SHPC454	2SHPC554	2SHPC654
7.5	2SHPC455	2SHPC555	2SHPC655
9	2SHPC457	2SHPC557	2SHPC657

- > 포장단위 : 1 Absolute Protection Cap
- > 치유기간 중 구강 내 Abutment를 보호하고 환자의 이물감을 최소화
- > Abutment의 보철 마진을 형성하기 위한 Gingival retraction에 사용
- > 임시 보철의 하부구조로 사용 가능

Absolute Impression Cap



Absolute Abutment Diameter	Ø4.5	Ø5.5	Ø6.5
Diameter / Height	Ø5.5	Ø6.5	Ø7.5
10.3	2SIC45	2SIC55	2SIC65

- > 포장단위 : 1 Absolute Impression Cap
- > Abutment의 직경에 따라 선택
- > 좌우로 회전하여 정확히 체결 되었는지 확인

Absolute Lab Analog



Absolute Abutment Diameter	Ø4.5	Ø5.5	Ø6.5
Diameter / Length	Ø4.5	Ø5.5	Ø6.5
4.1	2SHLA454	2SHLA554	2SHLA654
5.6	2SHLA455	2SHLA555	2SHLA655
7.1	2SHLA457	2SHLA557	2SHLA657

- > 포장단위 : 1 Absolute Lab Analog
- > Abutment analog로 작업모형 상에 Abutment 형상 구현
- > Abutment의 직경 및 길이에 따라 선택

Absolute Plastic Coping (Burn Out Cylinder)

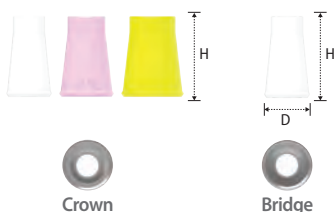

Type	Crown			Bridge		
Absolute Abutment Diameter	Ø4.5	Ø5.5	Ø6.5	Ø4.5	Ø5.5	Ø6.5
Diameter / Height	Ø5.1	Ø6.1	Ø7.1	Ø5.1	Ø6.1	Ø7.1
10	2SHBC45	2SHBC55	2SHBC65	2SHBB45	2SHBB55	2SHBB65

- > 포장단위 : 1 Absolute Plastic Coping
- > Absolute Lab Analog에 체결하여 보철물의 Framework로 사용
- > Abutment의 직경에 따라 선택

Prosthetic Procedure IV

Component Selection Guide for Straight Abutment

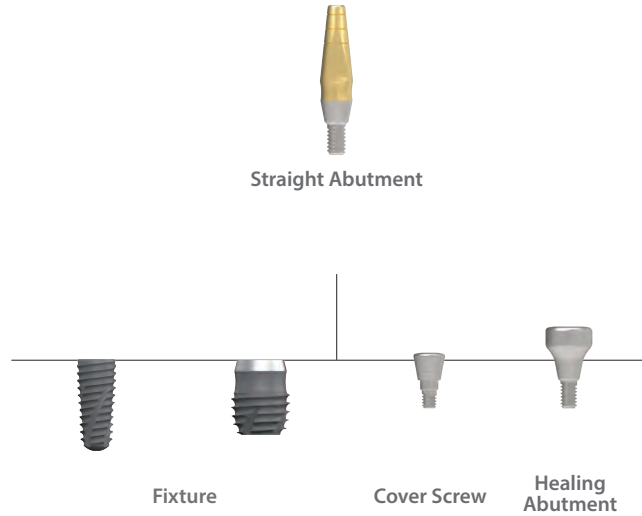

Straight Abutment

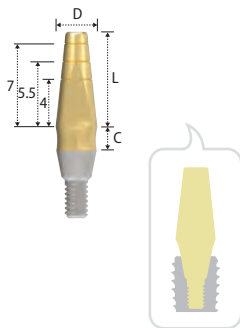

Diameter	Ø3.5	Ø4.5
Length	8	8
Cuff	8	8
0.5	2SSCM308	2SSCR408
1	2SSCM318	2SSCR418
2	2SSCM328	2SSCR428
3	2SSCM338	2SSCR438
4	2SSCM348	2SSCR448

- > 포장단위 : 1 Straight Abutment
- > CRP 유지형 보철 제작
- > Cutting Groove를 Guide로 하여 원하는 길이로 삭제하여 사용
- > 전치부 사용 권장
- > Shoulder Driver와 Torque Wrench를 사용하여 체결
- > 권장 체결 토크 : 30Ncm
- > Direct impression

Shoulder Ratchet Driver

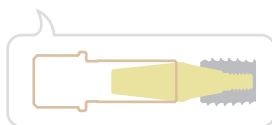
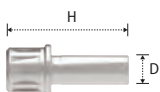

Diameter	Ø3.5	Ø4.5
Height	19	19
	KRR12S, KRR19L	KRW12S, KRW19L

- > 포장단위 : 1 Shoulder Driver
- > Torque Wrench를 사용하여 Straight Abutment 체결

Prosthetic Procedure V

Component Selection Guide for Sonator S&A Abutment

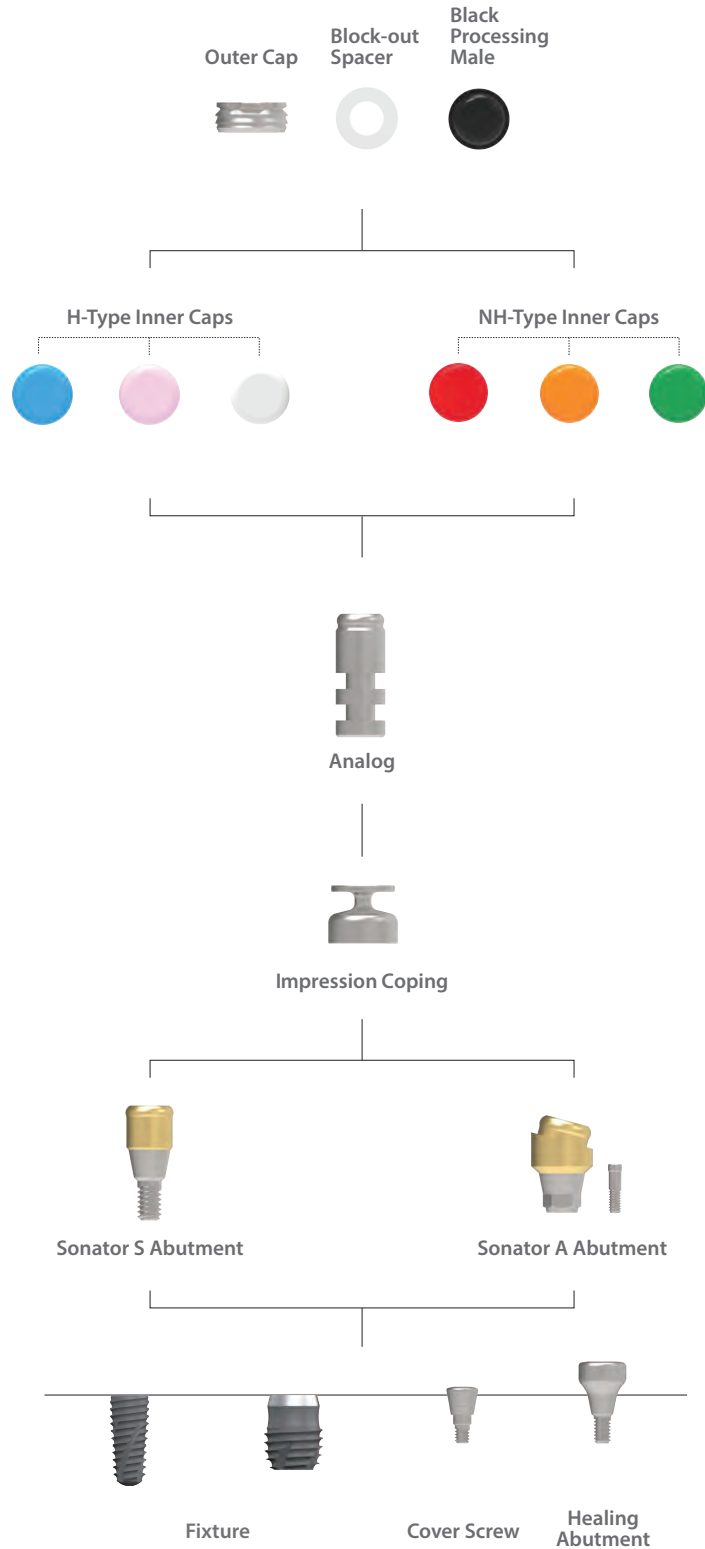

Sonator S Abutment

Diameter	Ø3.87					
Cuff Length	1	2	3	4	5	6
	SONS401	SONS402	SONS403	SONS404	SONS405	SONS406

- > 포장단위 : 1 Sonator S Abutment(Solid type) + 1 Carrier + 3 H-Type Inner Caps(유지력별 각 1개) + 1 Outer Cap + 1 Block-out Spacer + Black Processing Male
- > Implant supported ARP(Attachment Retained Prosthesis) 유지형 보철 제작
- > 낮은 Vertical height에서도 유지력 발휘
- > 6가지 종류 Inner Cap은 다양한 강도의 유지력 제공 (NH-Type 역시 사용 가능)
- > 2개 Fixture를 기준으로 20°까지 Path 보상
- > 심미성을 위한 Gold coloring
- > Carrier를 사용하여 안정적으로 구강 내 Abutment를 안정적으로 위치
- > Sonator S Driver 또는 Hex Driver와 Torque Wrench를 사용하여 체결
- > 권장 체결 토크 : 30Ncm
- > Abutment level impression

Sonator A Abutment

Diameter	Ø4.5	
Length	1.5	3.0
Cuff Angle	3	3
	15°	SONA415

- > 포장단위 : 1 Sonator A Abutment + 1 Abutment Screw(2SSHR300 + 1 Carrier + 3 NH-Type Inner Caps (유지력별 각 1개) + 1 Outer Cap + 1 Block-out Spacer + 1 Black Processing Male
- > Implant supported ARP(Attachment Retained Prosthesis) 유지형 보철 제작
- > 낮은 Vertical height에서도 유지력 발휘
- > 6가지 종류 Inner Cap은 다양한 강도의 유지력 제공 (H-Type 역시 사용 가능)
- > 2개 Fixture를 기준으로 40°까지 Path 보상
- > 심미성을 위한 Gold coloring
- > Carrier를 사용하여 안정적으로 구강 내 Abutment를 안정적으로 위치
- > Hex Driver와 Torque Wrench를 사용하여 체결
- > 권장 체결 토크 : 30Ncm
- > Abutment level impression

Abutment Screw



Diameter	Ø2.15
Height	2SSHR300

- > 포장단위 : 1 Abutment Screw
- > Sonator A Abutment 체결 시 사용
- > Hex Driver와 Torque Wrench를 사용하여 체결

Outer Cap

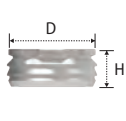

Black Processing Male



Diameter	Ø5.4
Height	SONOC01
	2.25

- > 포장단위 : 2 Outer Caps + 2 Black Processing Male
- > Black Processing Male: Sonator I&R Driver로 삽입 및 제거

H-Type Inner Cap



Block-out Spacer



Inner Cap

Blue:
Retention Force
About 10N

Pink:
Retention Force
About 15N

White:
Retention Force
About 22N



Code	SONIC01
------	---------

- > 포장단위 : 3 Block-out Spacers + 3 Inner Caps (유지력별 각 1개)
- > 돌출형 디자인
- > 유지력 : 10N, 15N, 22N
- > 2개 Fixture 기준으로 20°까지 Path 보상
- > Sonator S Abutment에 주로 사용
- > Sonator I&R Driver로 삽입 및 제거

NH-Type Inner Cap



Block-out Spacer



Inner Cap

Red:
Retention Force
About 10N

Orange:
Retention Force
About 15N

Green:
Retention Force
About 22N



Code	SONIC02
------	---------

- > 포장단위 : 3 Block-out Spacers + 3 Inner Caps (유지력별 각 1개)
- > 비돌출형 디자인
- > 유지력: 10N, 15N, 22N
- > 2개 Fixture 기준으로 40°까지 Path 보상
- > Sonator A Abutment에 주로 사용
- > Sonator I&R Driver로 삽입 및 제거

Sonator Impression Coping



Black Processing Male



Diameter	Ø4.8
Length	SONIP04
	3

- > 포장단위 : 4 Impression Copings
- > Closed tray 사용
- > Block-out Spacer 위치 후 Sonator Abutment 체결
- > Abutment level impression

Sonator Lab Analog



<i>Diameter</i>	Ø4
<i>Length</i>	SONLA04

- > 포장단위 : 4 Sonator Lab Analogs
- > Abutment analog로 작업모형 상에 Abutment 형상 구현

Sonator S Ratchet Driver

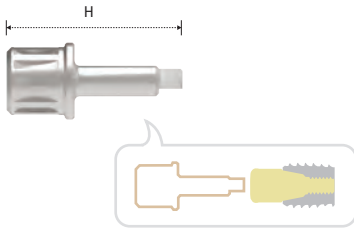

<i>Type</i>	Ratchet
<i>Height</i>	SONRD19L

- > 포장단위 : 1 Sonator S Ratchet Driver
- > Torque Wrench를 사용하여 Sonator S Abutment 체결

Sonator I&R Driver

<i>Height</i>	95.4
	SONIR002

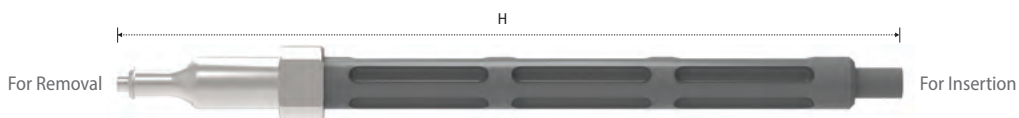

- > 포장단위 : 1 Sonator I&R Driver
- > Inner Cap 및 Black Processing Male 삽입 및 제거 시 사용

Prosthetic Procedure VI

Component Selection Guide for Ball Abutment

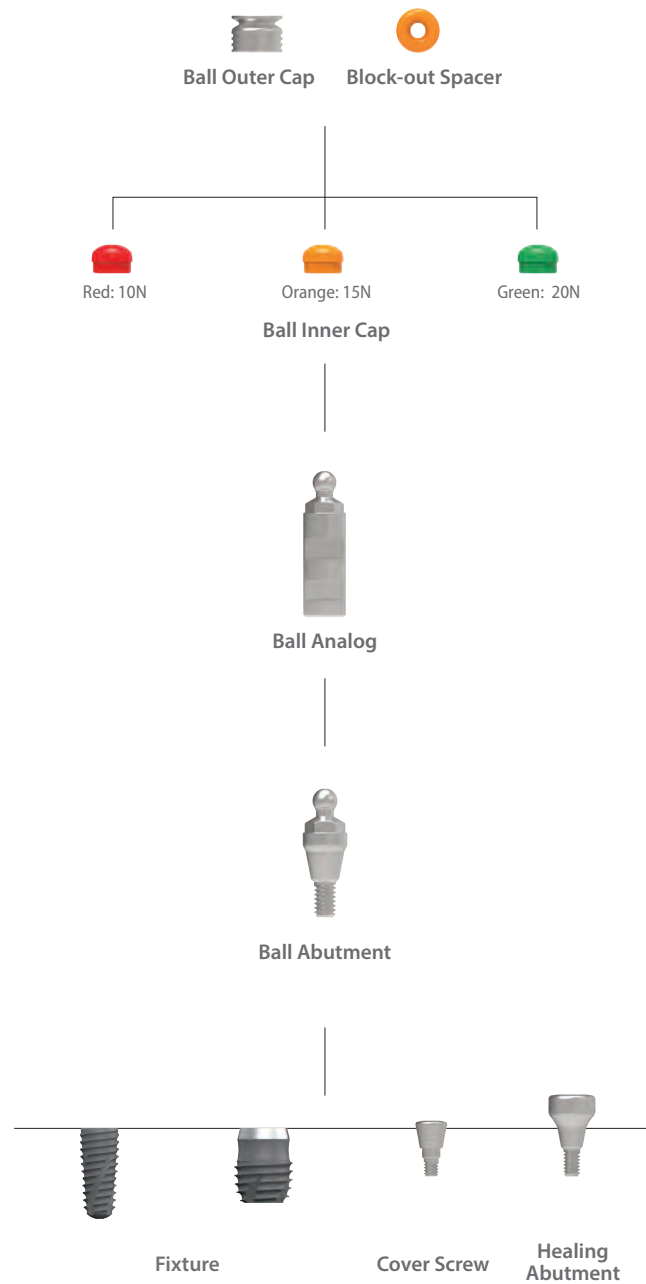

Ball Abutment

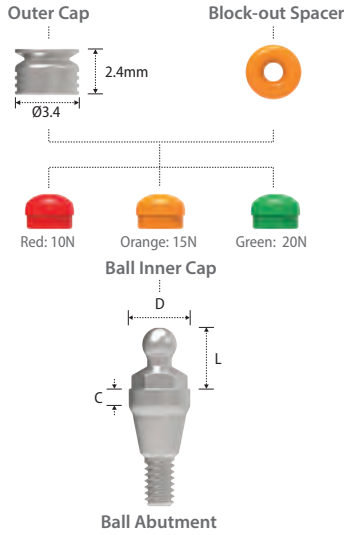

Diameter	Ø4.0
Length	4
Cuff	
1	2SBAT414R
2	2SBAT424R
3	2SBAT434R
4	2SBAT444R
5	2SBAT454R

- > 포장단위 : 1 Ball Abutment + 3 Inner Caps(유지력별 각 1개) + 1 Block-out Spacer + 1 Outer Cap
- > Implant supported ARP(Attachment Retained Prosthesis) 유지형 보철 제작
- > Ball Ratchet Driver와 Torque Wrench를 사용하여 체결
- > 권장 체결 토크: 30Ncm
- > Direct impression

Ball Outer Cap

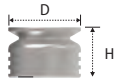

Diameter	Ø3.4
Height	2.6
	BATC003C

- > 포장단위 : 2 Outer Caps

Ball Inner Cap

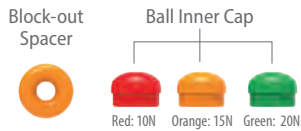

	BATC003I
--	----------

- > 포장단위 : 2 Block-out Spacers + 6 Inner Caps (유지력별 각 2개)
- > 유지력: 10N, 15N, 20N

Ball Analog



Diameter	Ø4.0
Length	4
	SBAL400

- > 포장단위 : 4 Ball Lab Analogs
- > Abutment analog로 작업모형 상에 Abutment 형상 구현

Ball Ratchet Driver

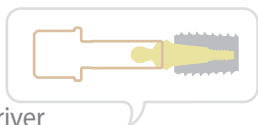
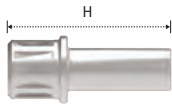

Type	Ratchet
Height	19
	KRB19L

- > 포장단위 : 1 Ball Ratchet Driver *Extra Product
- > Torque Wrench를 사용하여 Ball Abutment 체결

Ball I&R Driver

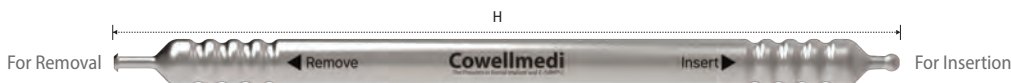

Height	100
	KBIR01



- > 포장단위 : 1 Ball I&R Driver
- > Inner Cap 삽입 및 제거 시 사용

INNO SUBMERGED NARROW IMPLANT (Sub-N.)

System Flow

Fixture	Abutment	
	<p>Prosthetic Procedure I</p>	 <p>Cemented Abutment Angulated Abutment Temporary Abutment</p>
	<p>Prosthetic Procedure II</p>	 <p>Straight Abutment</p>

Impression	
Fixture Level Impression	 <p>Replica</p> <p>Pick-up Impression Coping</p> <p>Transfer Post</p>
Abutment Level Impression	Direct Impression

INNO Submerged Narrow Implant (Sub-N.)



Submerged Fixture

Surface Treatment: **SLA-SH**

- > Interchangeable with hexagonal morse tapered fixture
- > Internal hex connection (Taper 11°/ Hex 2.1)
- > Narrow 전용 Mount 및 Abutment 사용



No-Mount > 포장단위 : 1 Fixture + 1 Cover Screw.

Diameter (실직경) **Ø3.1 (Ø3.3)**
 Length (실제 길이)

8 (8.5)	SR3108NSM
10	SR3110NSM
12	SR3112NSM
14	SR3114NSM

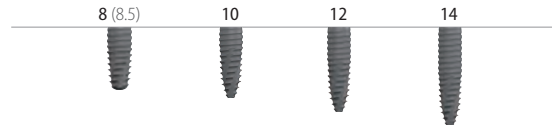

Diameter (실직경) **Ø3.3 (Ø3.5)**
 Length (실제 길이)

8 (8.5)	SR3308NSM
10	SR3310NSM
12	SR3312NSM
14	SR3314NSM

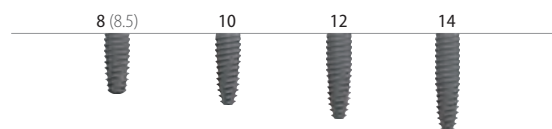

Pre-Mount > 포장단위 : 1 Fixture + 1 Cover Screw + 1 Mount.

Diameter (실직경)		Ø3.1 (Ø3.3)
Length (실제 길이)		
8 (8.5)	SR3108NS	
10	SR3110NS	
12	SR3112NS	
14	SR3114NS	

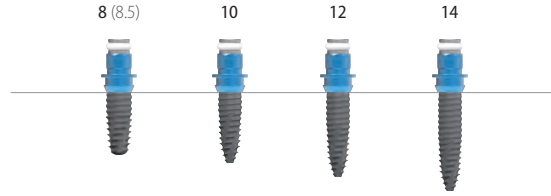

Diameter (실직경)		Ø3.3 (Ø3.5)
Length (실제 길이)		
8 (8.5)	SR3308NS	
10	SR3310NS	
12	SR3312NS	
14	SR3314NS	

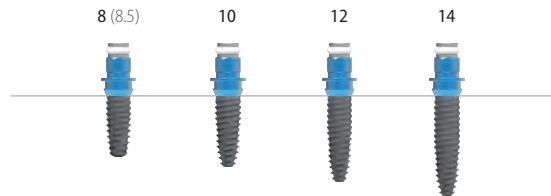

Fixture Mount

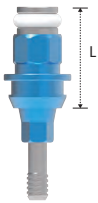

Length	5.4
	RSM001

- > 포장단위 : 1 Mount + 1 Mount Screw
- > Hex Driver를 사용하여 체결
- > 권장 체결 토크 : 5~10Ncm

Cover Screw



Diameter	Ø2.85	Ø3.25	Ø3.6
Length	1.7	2.7	3.7
	RCS000	RCS001	RCS002

- > 포장단위 : 1 Cover Screw
- > Fixture 식립 후 Fixture connection 보호
- > 깊게 식립 시 Long Cover Screw 사용
- > Hex Driver를 사용하여 체결
- > 권장 체결 토크 : 5~10Ncm

Healing Abutment

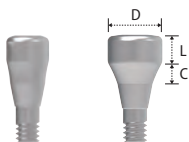

Diameter	Ø3.5		Ø4.5	
Cuff	1	2	1	2
Length	0.5	1	2	3
	HR3501	HR3511	HR3522	HR3532
			HR3542	
				HS4511N
				HS4522N
				HS4532N
				HS4542N
				HS4552N
				HS4572N

- > 포장단위 : 1 Healing Abutment
- > 치유기간 동안 Fixture에 체결하여 치은 형태 형성
- > 치은 높이 및 사용 Abutment에 따라 선택 사용
- > Hex Driver를 사용하여 체결
- > 권장 체결 토크 : 5~10Ncm

Prosthesis Procedure I

Components Selection Guide for Cemented and Temporary Abutment

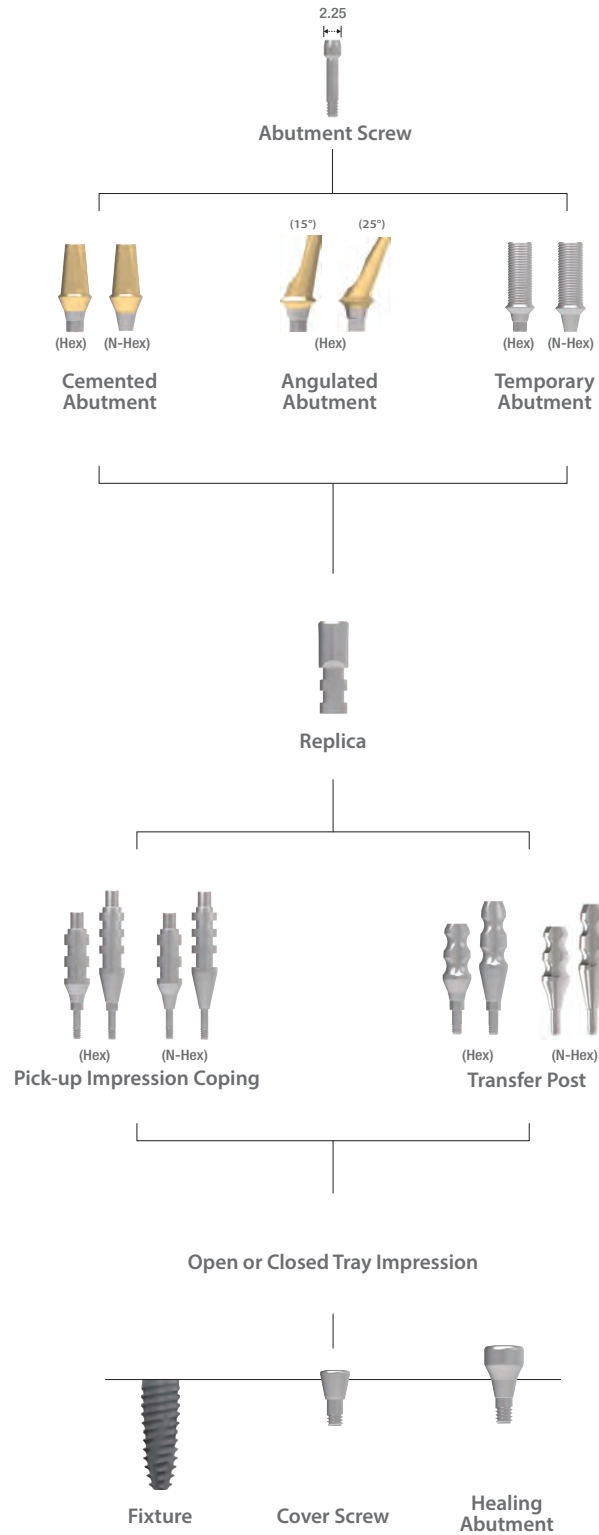

Cemented Abutment

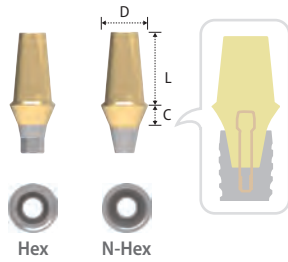

Type	Hex			N-Hex		
Diameter	Ø4.5					
Length / Cuff	4	5.5	7	4	5.5	7
1	SCH4514N	SCH4515N	SCH4517N	SCN4514N	SCN4515N	SCN4517N
2	SCH4524N	SCH4525N	SCH4527N	SCN4524N	SCN4525N	SCN4527N
3	SCH4534N	SCH4535N	SCH4537N	SCN4534N	SCN4535N	SCN4537N
4	SCH4544N	SCH4545N	SCH4547N	SCN4544N	SCN4545N	SCN4547N
5	SCH4554N	SCH4555N	SCH4557N	SCN4554N	SCN4555N	SCN4557N

- > 포장단위 : 1 Cemented Abutment + 1 Abutment Screw(2SSHR200)
- > CRP 및 SCRP 유지형 보철 제작
- > 회전방지 단면 부여
- > 심미성을 위한 Gold coloring
- > Scanbody 사용 시 Digital work 가능
- > 3shape 및 Exocad용 라이브러리 제공
- > Hex Driver와 Torque Wrench를 사용하여 체결
- > 권장 체결 토크 : 30Ncm
- > Fixture level impression

Angulated Abutment

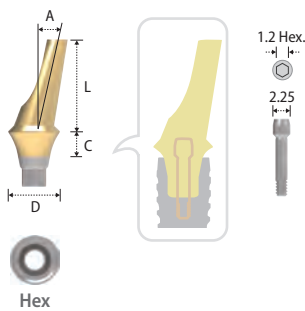

Type	Hex	
Diameter(Angle)	Ø4.5(15°)	Ø4.5(25°)
Length / Cuff	8	
1	SAH45151NA	SAH45251NA
2	SAH45152NA	SAH45252NA
3	SAH45153NA	SAH45253NA
4	SAH45154NA	SAH45254NA

- > 포장단위 : 1 Angulated Abutment + 1 Abutment Screw(2SSHR100)
- > CRP 유지형 보철 제작
- > Fixture path를 보상(최대 25°) 및 전치부에 사용
- > 심미성을 위한 Gold coloring
- > Scanbody 사용 시 Digital work 가능
- > 3shape 및 Exocad용 라이브러리 제공
- > Hex Driver와 Torque Wrench를 사용하여 체결
- > 권장 체결 토크 : 30Ncm
- > Fixture level impression

Temporary Abutment

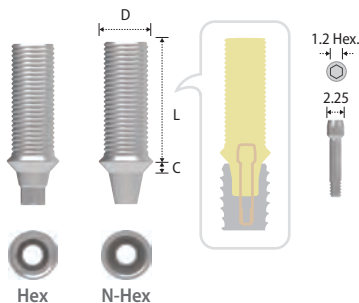

Type	Hex	N-Hex
Diameter	Ø4.5	
Length / Cuff	10	
1	STHA45N	STNA45N

- > 포장단위 : 1 Temporary Abutment + 1 Abutment Screw(2SSHR100)
- > CRP, SRP 및 SCRP 유지형 임시 보철 제작
- > Resin 탈락 방지를 위한 Groove 부여
- > Hex Driver와 Torque Wrench를 사용하여 체결
- > 권장 체결 토크 : 30Ncm
- > Fixture level impression

Abutment Screw

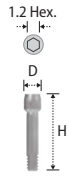

<i>Diameter</i>	2.25
<i>Height</i>	10.2
	SSHR100N

- > 포장단위 : 1 Abutment Screw
- > Hex Driver와 Torque Wrench를 사용하여 체결

Replica



<i>Diameter</i>	Ø4
<i>Height</i>	12.1
	SRHR001N

- > 포장단위 : 1 Replica
- > Fixture analog로 작업모형 상에 Fixture 형상 구현

Pick-up Impression Coping

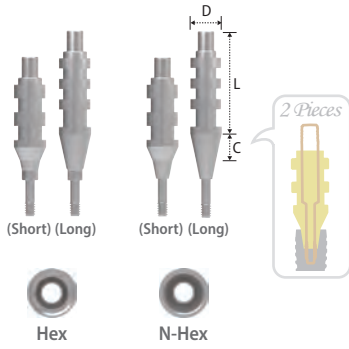

Type	Hex	N-Hex
<i>Diameter</i>	Ø4.5	Ø4.5
<i>Length / Cuff</i>		
14 (Short) / 2	SIH45SN	SIN45SN
16 (Long) / 4	SIH45LN	SIN45LN

- > 포장단위 : 1 Pick-up Impression Coping + 1 Guide Pin(SISR001SN / SISR001LN)
- > Open tray 사용(Custom tray)
- > Hex Driver를 사용하여 체결
- > 권장 체결 토크 : 12~15Ncm
- > Fixture level impression

Transfer Post

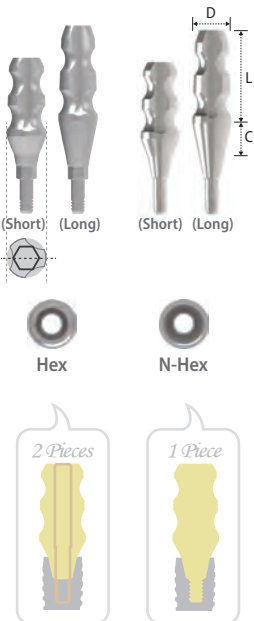

Type	Hex	N-Hex
<i>Diameter</i>	Ø4.5	Ø4.5
<i>Length / Cuff</i>		
9 (Short) / 2	STH45SN	STN45SN
11 (Long) / 4	STH45LN	STN45LN

- > 포장단위 : Hex- 1 Transfer Post + 1 Guide Pin(STH001SN / STH001LN)
N-Hex- 1 Transfer Post(Solid type)
- > Closed tray 사용
- > Hex Driver를 사용하여 체결
- > 권장 체결 토크 : 12~15Ncm
- > Fixture level impression

Prosthetic Procedure II

Component Selection Guide for Straight Abutment

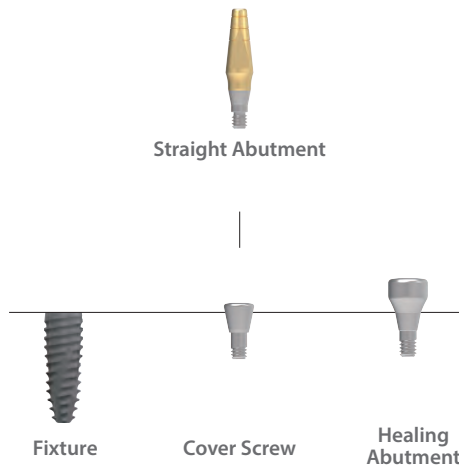

Straight Abutment

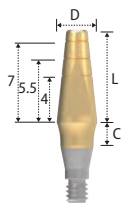

Diameter	Ø3.5				
Length [Cuff]	8 [0.5]	8 [1]	8 [2]	8 [3]	8 [4]
	SR308	SR318	SR328	SR338	SR348

- > 포장단위 : 1 Straight Abutment
- > CRP 유지형 보철 제작
- > Cutting Groove를 Guide로 하여 원하는 길이로 삭제하여 사용
- > 전치부 사용 권장
- > Shoulder Driver와 Torque Wrench를 사용하여 체결
- > 권장 체결 토크 : 30Ncm
- > Direct impression

Shoulder Ratchet Driver

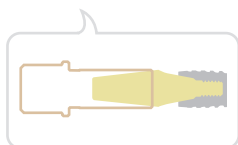







Diameter	Ø4.5
Height	19
	KRR19L





- > 포장단위 : 1 Shoulder Driver
- > Torque Wrench를 사용하여 Straight Abutment 체결

MMO Implant System

INNO INTERNAL IMPLANT (Int.)

System Flow

Fixture	Abutment			
 <p>Octa 3.1</p> <p>Platform Ø4.8 / 5.9</p> <p>Cuff 1.8 / 2.4mm</p> <p>Length 7 ~ 14mm</p> <p>Diameter Ø3.5 (3.7) Ø4.0 (4.0) Ø4.5 (4.6) Ø5.0 (5.1) Ø6.0 (5.9)</p>	Prosthetic Procedure I	 Cemented Extension Abutment	 Angulated Abutment	 Meta G UCLA Abutment
	Prosthetic Procedure II	 Solid Abutment		
	Prosthetic Procedure III	 Shoulder Abutment		
	Prosthetic Procedure IV	 Ball Abutment		

	Impression
Fixture Level Impression	<div style="display: flex; justify-content: space-around; align-items: center;"> <div style="text-align: center;">  Replica </div> <div style="text-align: center;">  Pick-up Impression Coping </div> <div style="text-align: center;">  Transfer Post </div> </div>
Abutment Level Impression	<div style="display: flex; justify-content: space-around; align-items: center;"> <div style="text-align: center;">  Solid/Shoulder Protection Cap </div> <div style="text-align: center;">  Solid/Shoulder Impression Cap </div> <div style="text-align: center;">  Solid Positioning Cylinder </div> <div style="text-align: center;">  Solid Lab Analog </div> <div style="text-align: center;">  Solid Plastic Coping </div> </div>
	<div style="display: flex; justify-content: space-around; align-items: center;"> <div style="text-align: center;">  Solid/Shoulder Protection Cap </div> <div style="text-align: center;">  Solid/Shoulder Impression Cap </div> <div style="text-align: center;">  Shoulder Positioning Cylinder </div> <div style="text-align: center;">  Shoulder Lab Analog </div> </div>
	<div style="text-align: center;">  Ball Analog </div>

INNO Internal Implant (Int.)



Internal Fixture
Surface Treatment: **SLA-SH™**

- > Interchangeable with 1 staged internal fixture
- > Internal Octa Connection (Taper 8°/ Octa 3.1)
- > No-Mount type

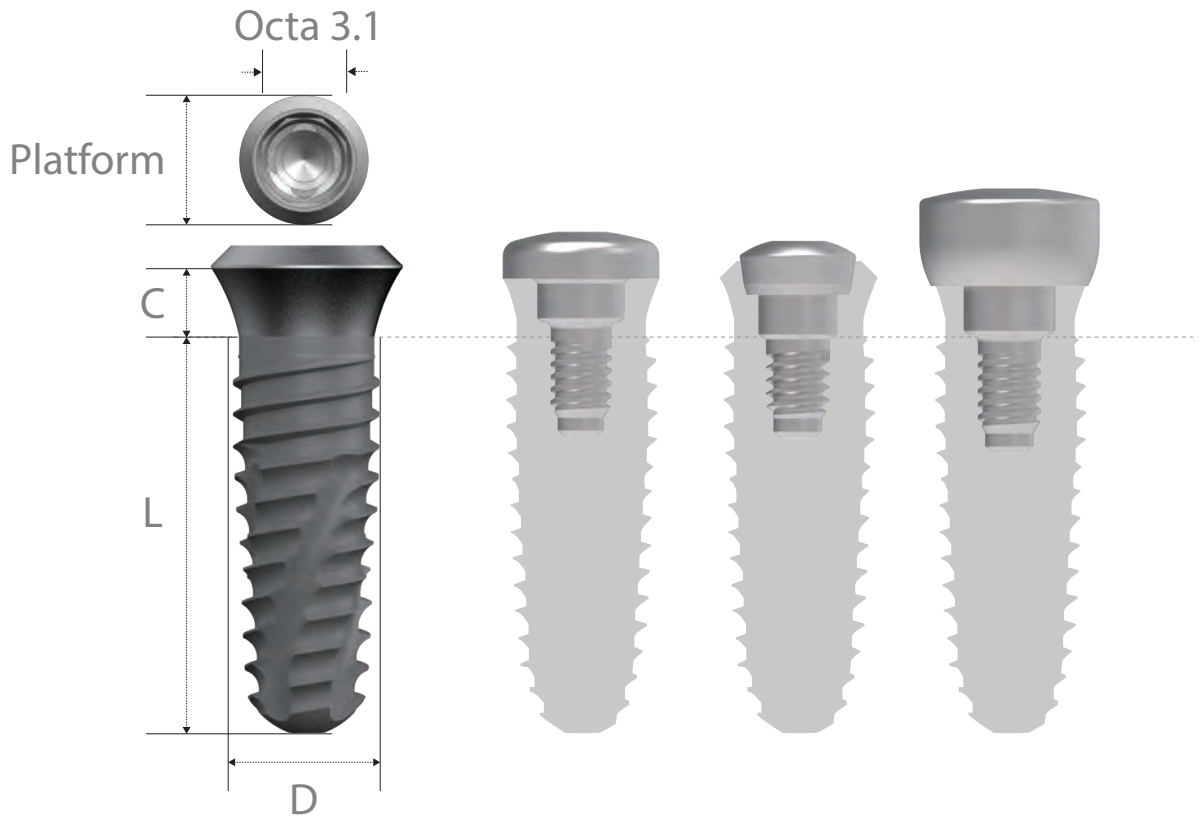

INNO Fixture Code

I	P	T	40	10	S	M	*Ex.) SLA Cuff 1.8 No-Mount	IPT4010SM
Type Internal	P=Cuff 1.8	body Taper	Diameter Ø4.0	Length 10mm	Surface Treatment SLA	Mount No-Mount		

I		T	40	10	S	M	*Ex.) SLA Cuff 2.4 No-Mount	IT4010SM
Type Internal	Cuff 2.4	body Taper	Diameter Ø4.0	Length 10mm	Surface Treatment SLA	Mount No-Mount		

No-Mount Cuff 1.8mm fixture > 포장단위: 1 Fixture + 1 Cover Screw

* Diameter (실직경) **Ø3.5 (Ø3.7)**

Length

7	-
8	IPT3508SM
10	IPT3510SM
12	IPT3512SM
14	IPT3514SM

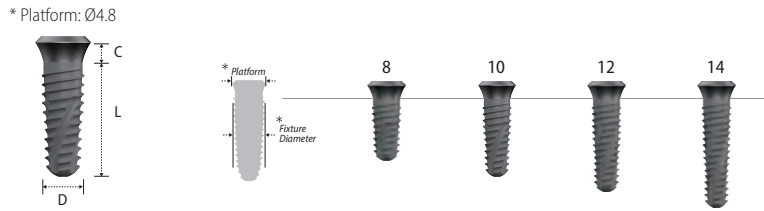

* Diameter (실직경) **Ø4.0 (Ø4.2)**

Length

7	IPT4007SM
8	IPT4008SM
10	IPT4010SM
12	IPT4012SM
14	IPT4014SM

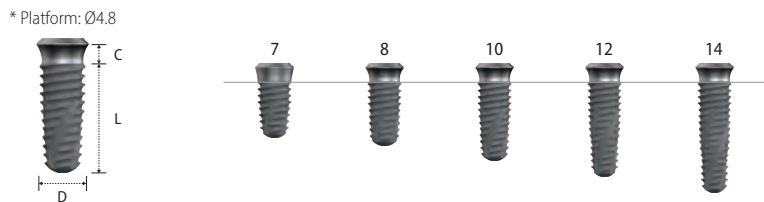

* Diameter (실직경) **Ø4.5 (Ø4.6)**

Length

7	IPT4507SM
8	IPT4508SM
10	IPT4510SM
12	IPT4512SM
14	IPT4514SM

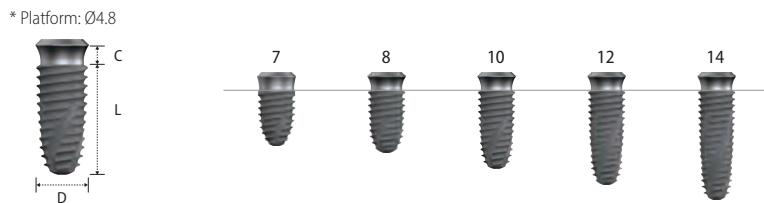

* Diameter (실직경) **Ø5.0 (Ø5.1)**

Length

7	IPT5007SM
8	IPT5008SM
10	IPT5010SM
12	IPT5012SM
14	IPT5014SM

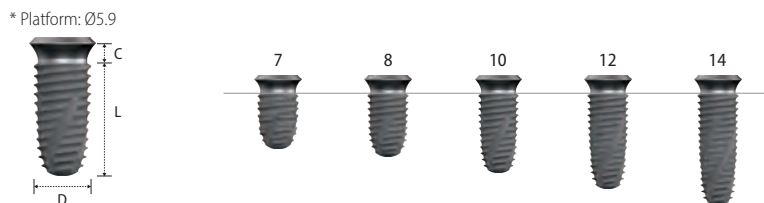

* Diameter (실직경) **Ø6.0 *(Ø5.9)**

Length (실제 길이)

7	*IPT6007SM
8 (7.5)	IPT6008SM
10 (9.5)	IPT6010SM
12 (11.5)	IPT6012SM
14	-

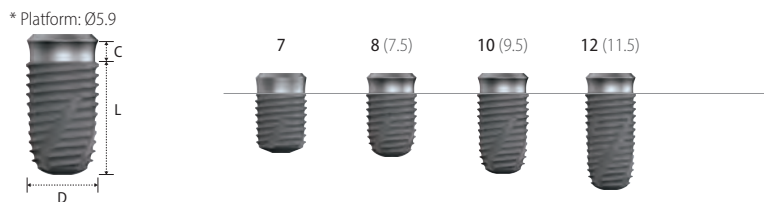

No-Mount Cuff 2.4mm fixture > 포장단위: 1 Fixture + 1 Cover Screw

* Diameter (실직경) **Ø3.5 (Ø3.7)**

Length

7	-
8	IT3508SM
10	IT3510SM
12	IT3512SM
14	IT3514SM

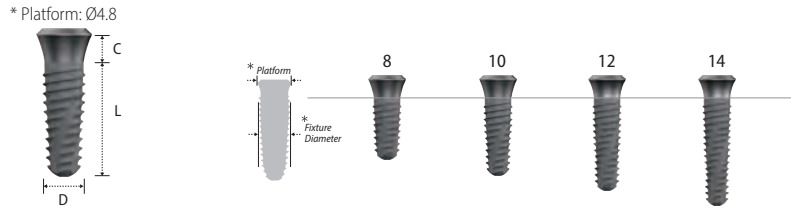

* Diameter (실직경) **Ø4.0 (Ø4.2)**

Length

7	IT4007SM
8	IT4008SM
10	IT4010SM
12	IT4012SM
14	IT4014SM

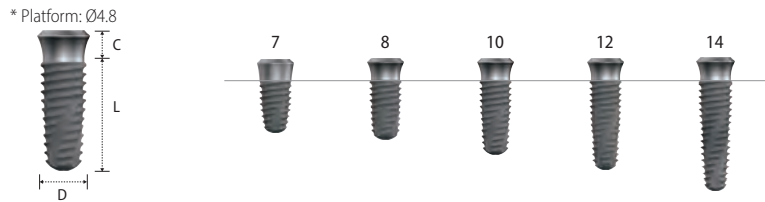

* Diameter (실직경) **Ø4.5 (Ø4.6)**

Length

7	IT4507SM
8	IT4508SM
10	IT4510SM
12	IT4512SM
14	IT4514SM

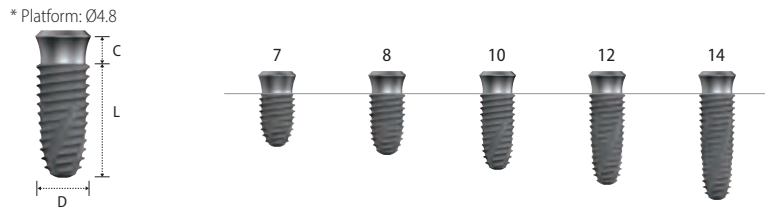

* Diameter (실직경) **Ø5.0 (Ø5.1)**

Length

7	IT5007SM
8	IT5008SM
10	IT5010SM
12	IT5012SM
14	IT5014SM

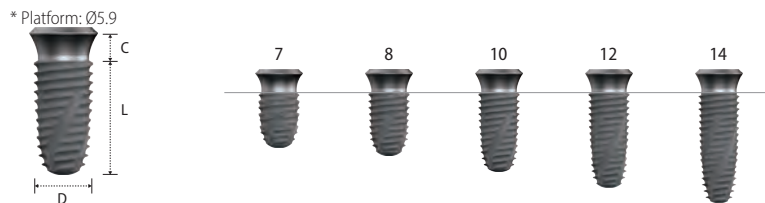

* Diameter (실직경) **Ø6.0 *(Ø5.9)**

Length (실제 길이)

7	*IT6007SM
8 (7.5)	IT6008SM
10 (9.5)	IT6010SM
12 (11.5)	IT6012SM
14	-

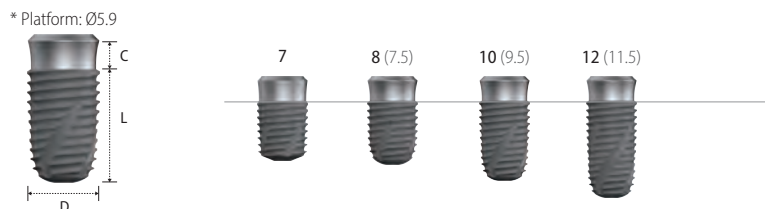

Cover Screw



Platform [Fixture Dia.]	Ø4.8 [Ø3.5 / Ø4.0 / Ø4.5]	Ø5.9 [Ø5.0 / Ø6.0]	
Diameter	Ø5.0	Ø6.0	
Height	6.5	ICVR002	ICVW002

- > 포장단위 : 1 Cover Screw
- > Fixture 식립 후 Fixture connection 보호
- > Fixture platform에 따라 선택 사용
- > Hex Driver를 사용하여 체결
- > 권장 체결 토크 : 5~10Ncm

Headless Screw



Diameter	Ø3.5	
Height	6	ICVR001

- > 포장단위 : 1 Headless Screw
- > 공간이 제한적이거나 봉합부 치은이 부족할 경우 사용
- > Hex Driver를 사용하여 체결
- > 권장 체결 토크 : 5~10Ncm

Healing Abutment



Platform [Fixture Dia.]	Ø4.8 [Ø3.5 / Ø4.0 / Ø4.5]	Ø5.9 [Ø5.0 / Ø6.0]	
Diameter	Ø5.5	Ø6.6	
Length	2	IHCR020	IHCW020
	3	IHCR030	IHCW030
	4.5	IHCR045	IHCW045

- > 포장단위 : 1 Healing Abutment
- > 치유기간 동안 Fixture에 체결하여 치은 형태 형성
- > Fixture platform, 치은 높이 및 사용 Abutment에 따라 선택 사용
- > Hex Driver를 사용하여 체결
- > 권장 체결 토크 : 5~10Ncm

Internal Ti-Block

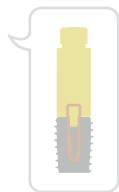
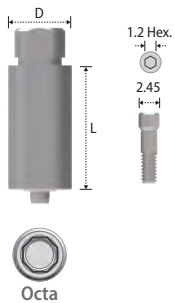

Type	Octa		
Platform	Ø4.8[Ø3.5 / Ø4.0 / Ø4.5]	Ø5.9 [Ø5.0 / Ø6.0]	
Diameter	10	10	
Length	20	CIOR10S	CIOW10S

- > 포장단위 : 1 Hybrid Ti-Block + 2 Abutment Screws
- > CRP 및 SCRП 유지형 보철 제작
- > 3shape, Exocad용 라이브러리 제공
- > Hex Driver와 Torque Wrench로 체결
- > 권장 체결 토크 : 30Ncm

Scanbody

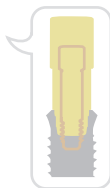
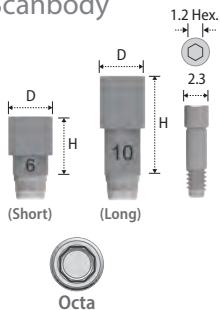

Type	Octa(Short)	Octa(Long)
Platform [Fixture Dia.]	Ø4.8 & Ø5.9 [Ø3.5 / Ø4.0 / Ø4.5 / Ø5.0 / Ø6.0]	Ø4.8 & Ø5.9 [Ø3.5 / Ø4.0 / Ø4.5 / Ø5.0 / Ø6.0]
Diameter	Ø4.5	Ø4.5
Height	6	10
	ISB406	ISB410

- > 포장단위 : 1 Scanbody + 1 Abutment Screw
- > 모델스캐너 및 구강스캐너 모두 사용 가능
- > 특수 코팅 적용한 100% 티타늄 합금
- > Scan spray 과정 불필요
- > Abutment Screw(ISHR110)와 체결
- > Hex Driver와 Torque Wrench를 사용하여 체결
- > 권장 체결 토크 : 12~15Ncm

Prosthetic Procedure I

Component Selection Guide for Cemented & UCLA Abutment

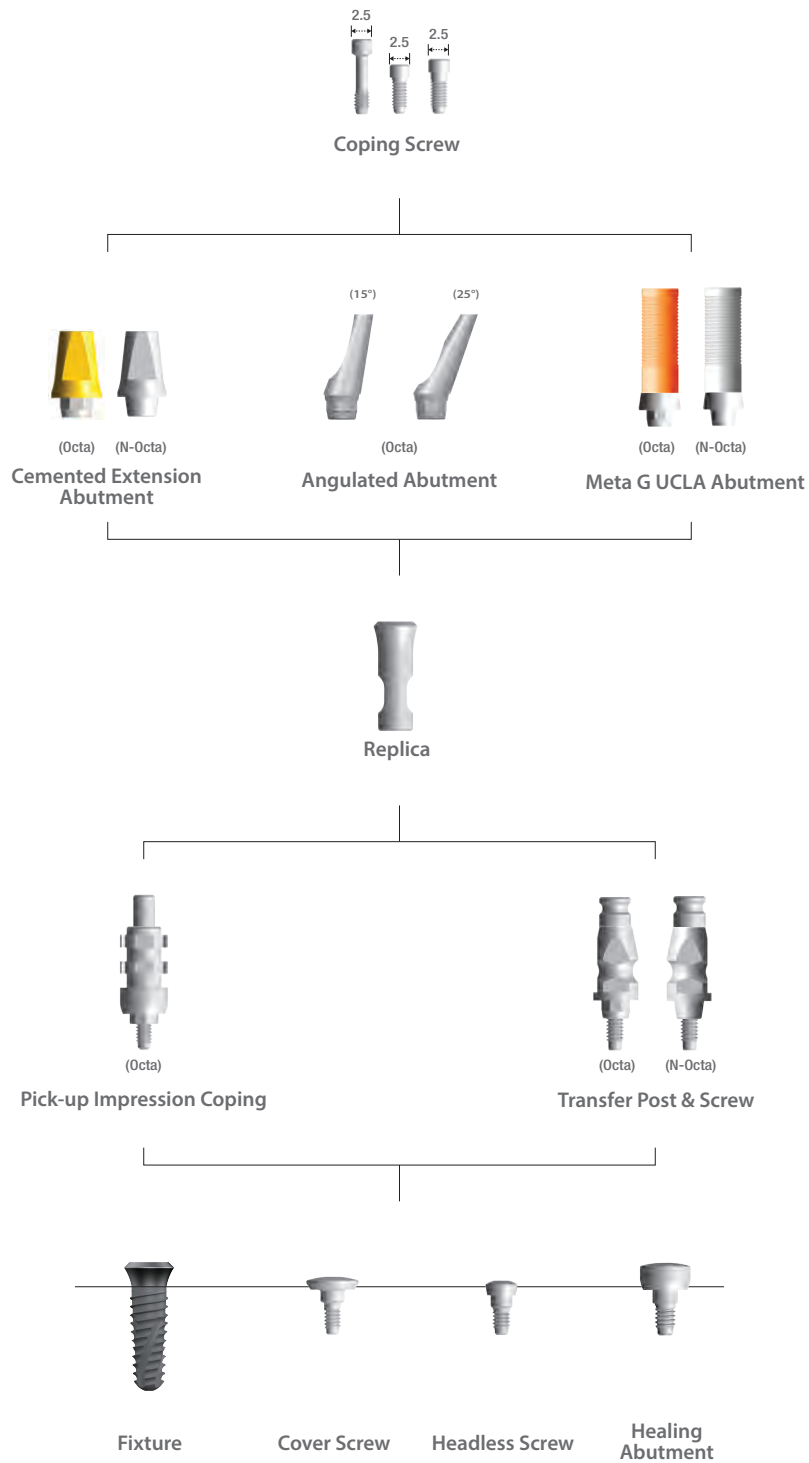

Cemented Extension Abutment

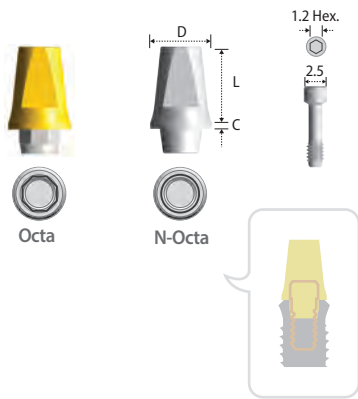

Type	Octa			
Platform [Fixture Dia.]	Ø4.8 [Ø3.5 / Ø4.0 / Ø4.5]		Ø5.9 [Ø5.0 / Ø6.0]	
Diameter	Ø4.8	Ø5.8	Ø5.9	Ø6.9
Cuff Length	6	6	6	6
0.5	IECR406		IECW506	
1		IECR416		IECW516
2		IECR426		IECW526
3		IECR436		IECW536
Type	N-Octa			
Platform [Fixture Dia.]	Ø4.8 [Ø3.5 / Ø4.0 / Ø4.5]		Ø5.9 [Ø5.0 / Ø6.0]	
Diameter	Ø4.8	Ø5.8	Ø5.9	Ø6.9
Cuff Length	6	6	6	6
0.5	IENR406		IENW506	
1		IENR416		IENW516
2		IENR426		IENW526
3		IENR436		IENW536

- > 포장단위 : 1 Cemented Abutment + 1 Abutment Screw(ISHR110)
- > CRP 및 SCRП 유지형 보철 제작
- > 회전방지 단면 부여
- > Hex Driver와 Torque Wrench를 사용하여 체결
- > 권장 체결 토크 : 30Ncm
- > Fixture level impression

Angulated Abutment

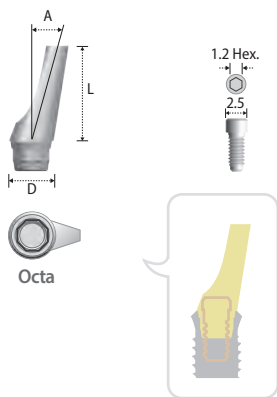

Type	Octa	
Platform [Fixture Dia.]	Ø4.8 & Ø5.9 [Ø3.5 / Ø4.0 / Ø4.5 / Ø5.0 / Ø6.0]	
Diameter(Angle)	3.8 (15°)	3.8 (25°)
Length	8	8
	IAAR158A	IAAR258A

- > 포장단위 : 1 Angulated Abutment + 1 Abutment Screw(ISHR100)
- > CRP 유지형 보철 제작
- > Fixture path를 보상(최대 25°) 및 전치부에 사용
- > Hex Driver와 Torque Wrench를 사용하여 체결
- > 권장 체결 토크 : 30Ncm
- > Fixture level impression

Meta G UCLA Abutment

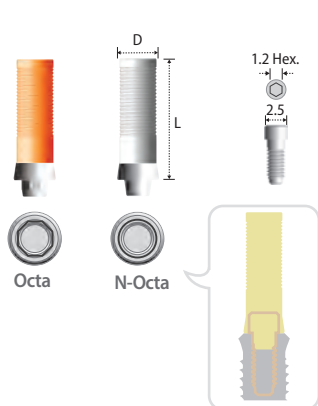

Type	Octa		N-Octa	
Platform [Fixture Dia.]	Ø4.8 [Ø3.5 / Ø4.0 / Ø4.5]	Ø5.9 [Ø5.0 / Ø6.0]	Ø4.8 [Ø3.5 / Ø4.0 / Ø4.5]	Ø5.9 [Ø5.0 / Ø6.0]
Diameter	Ø5	Ø6	Ø5	Ø6
Length	12	12	12	12
	IGOR400N	IGOW500N	IGNR400N	IGNW500N

- > 포장단위 : 1 Meta G UCLA Abutment + 1 Abutment Screw(ISHR120)
- > CRP, SRP 및 SCRП 유지형 보철 제작
- > Path 조정, 심미 등을 위한 Customizing이 필요한 경우에 사용
- > 비귀금속 합금을 사용하여 Casting하여 보철물 제작
- > Metal base로 Connection부의 정밀도가 높음
- > Hex Driver와 Torque Wrench를 사용하여 체결
- > 권장 체결 토크 : 30Ncm
- > Fixture level impression

Abutment Screw

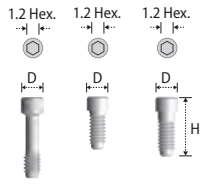

Diameter	Ø2.5	Ø2.5	Ø2.5
Height	6.3	ISHR100	
	7.8		ISHR120
	9.2	ISHR110	

- > 포장단위 : 1 Abutment Screw
- > ISHR100 : Angulated Abutment
- > ISHR110 : Cemented Extension Abutment
- > ISHR120 : Meta G UCLA Abutment
- > Hex Driver와 Torque Wrench를 사용하여 체결

Replica



Platform [Fixture Dia.]	Ø4.8 [Ø3.5 / Ø4.0 / Ø4.5]	Ø5.9 [Ø5.0 / Ø6.0]
Diameter	Ø4.8	Ø5.9
Height	12	12
	IROR001	IROW001

- > 포장단위 : 1 Replica
- > Fixture analog로 작업모형 상에 Fixture 형상 구현

Pick-up Impression Coping

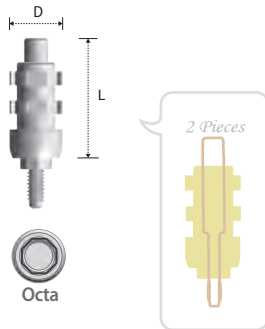

Type	Octa	
Platform [Fixture Dia.]	Ø4.8 [Ø3.5 / Ø4.0 / Ø4.5]	Ø5.9 [Ø5.0 / Ø6.0]
Diameter	Ø5.5	Ø6.6
Length	13.7	13.7
	IIOR001	IHOW001

- > 포장단위 : 1 Pick-up Impression Coping + 1 Guide Pin(IIOR001S)
- > Open tray 사용(Custom tray)
- > Hex Driver를 사용하여 체결
- > 권장 체결 토크 : 12~15Ncm
- > Fixture level impression

Transfer Post

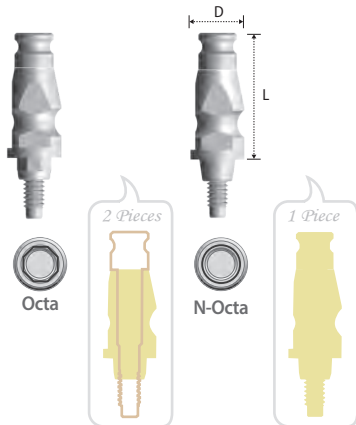

Type	Octa		N-Octa	
Platform [Fixture Dia.]	Ø4.8 [Ø3.5 / Ø4.0 / Ø4.5]	Ø5.9 [Ø5.0 / Ø6.0]	Ø4.8 [Ø3.5 / Ø4.0 / Ø4.5]	Ø5.9 [Ø5.0 / Ø6.0]
Diameter	Ø4.85	Ø5.95	Ø4.85	Ø5.95
Length	11.6	11.6	11.6	11.6
	ITOR400	ITOW500	ITNR400	ITNW500

- > 포장단위 : Octa- 1 Transfer Post + 1 Guide Pin(ITOR400S / ITOW500S)
- > N-Octa- 1 Transfer Post(Solid type)
- > Closed tray 사용
- > Hex Driver를 사용하여 체결
- > 권장 체결 토크 : 12~15Ncm
- > Fixture level impression

Prosthetic Procedure II

Component Selection Guide for Solid Abutment

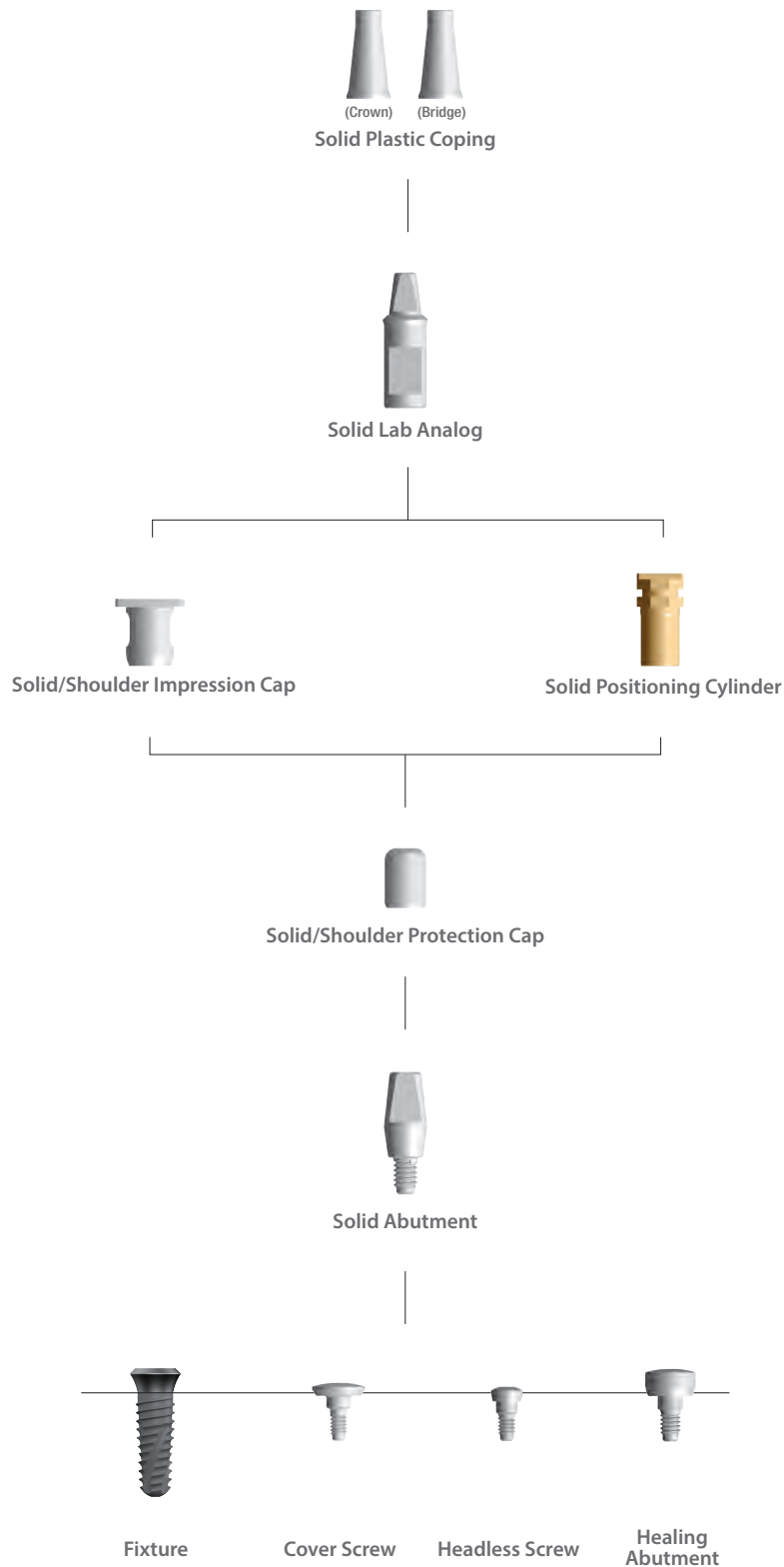

Solid Abutment

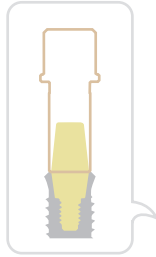

Platform [Fixture Dia.]	Ø4.8 & Ø5.9 [Ø3.5 / Ø4.0 / Ø4.5 / Ø5.0 / Ø6.0]			
Diameter	Ø3.5			
Length	3	4	5.5	7
	IASR030	IASR040	IASR055	IASR070

- > 포장단위 : 1 Solid Abutment(Solid type) + 1 Protection Cap
- > CRP 유지형 보철 제작
- > 회전방지 단면 부여
- > Shoulder Ratchet Driver와 Torque Wrench를 사용하여 체결
- > 권장 체결 토크 : 30Ncm
- > Platform Ø4.8 Fixture(Ø3.5, 4.0, 4.5) : Impression Cap 사용 인상 채득
- > Platform Ø5.9 Fixture(Ø5.0, 6.0) : Direct impression

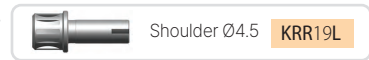

Solid/Shoulder Protection Cap



Solid Abutment Diameter	Ø3.5
Diameter / Height	Ø5.4
5.2	IASR130
6.2	IASR140
7.7	IASR155
9.2	IASR170

- > 포장단위 : 1 Solid/Shoulder Protection Cap
- > 치유기간 중 구강 내 Abutment를 보호하고 환자의 이물감을 최소화
- > Abutment의 보철 마진을 형성하기 위한 Gingival retraction에 사용
- > 임시 보철의 하부구조로 사용 가능

Solid/Shoulder Impression Cap

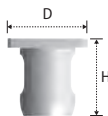

Solid Abutment Diameter	Ø3.5
Diameter / Height	8
8	IICR001

- > 포장단위 : 1 Solid/Shoulder Impression Cap
- > Positioning Cylinder를 체결하여 인상 채득에 사용
- > 좌우로 회전하여 정확히 체결 되었는지 확인

Solid Positioning Cylinder



Solid Abutment Diameter	Ø3.5		
Diameter	Ø5.7		
Height	10.2	IPCR001	

- > 포장단위 : 1 Solid Positioning Cylinder
- > Abutment의 회전을 방지하기 위한 내부 단면 부여
- > Impression Cap에 체결

Solid Lab Analog



Solid Abutment Diameter	Ø3.5			
Diameter	Ø4.8			
Length	3	4	5.5	7
	ILSR030	ILSR040	ILSR055	ILSR070

- > 포장단위 : 1 Solid Lab Analog
- > Abutment analog로 작업모형 상에 Abutment 형상 구현
- > 사용 Abutment에 따라 선택

Solid Plastic Coping

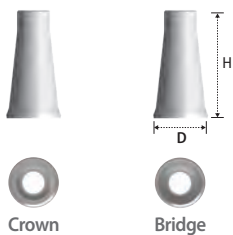

Type	Crown	Bridge
Solid Abutment Diameter	Ø3.5	Ø3.5
Diameter	Ø5	Ø5
Height	10	IPCB001

- > 포장단위 : 1 Solid Plastic Coping
- > Solid Lab Analog에 체결하여 보철물의 Framework로 사용

Prosthetic Procedure III

Component Selection Guide for Shoulder Abutment

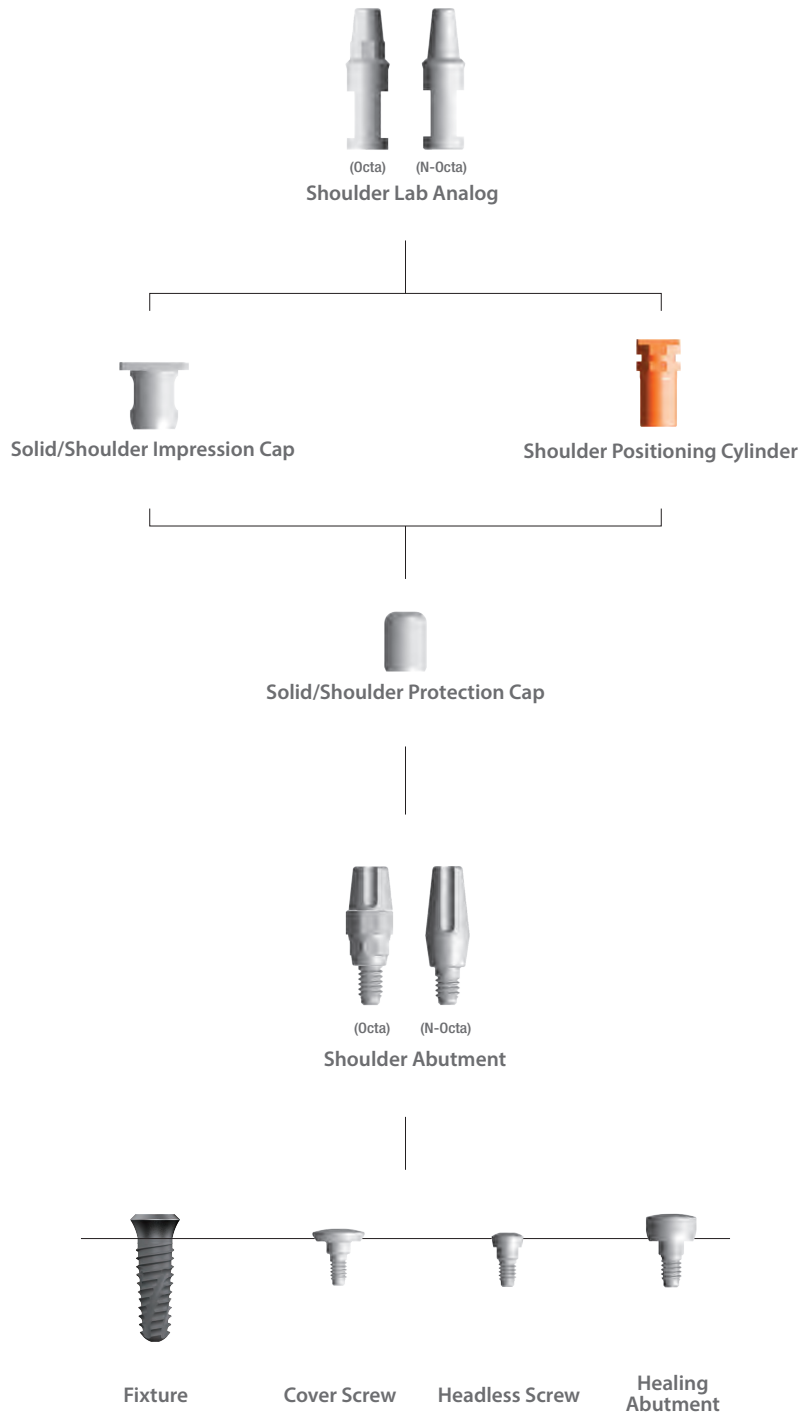

Shoulder Abutment

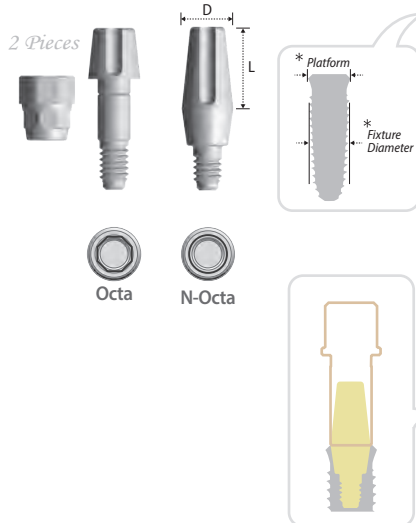

Type	Octa		N-Octa	
* Platform [Fixture Dia.]	Ø4.8 [Ø3.5 / Ø4.0 / Ø4.5]	Ø5.9 [Ø5.0 / Ø6.0]	Ø4.8 [Ø3.5 / Ø4.0 / Ø4.5]	Ø5.9 [Ø5.0 / Ø6.0]
Diameter	Ø3.5	Ø4.5	Ø3.5	Ø4.5
Length				
4	ISAC404	ISAC504	ISAB404	ISAB504
5.5	ISAC405	ISAC505	ISAB405	ISAB505
7	ISAC407	ISAC507	ISAB407	ISAB507

- > 포장단위 : 1 Solid Abutment(Solid type) + 1 Protection Cap
- > CRP 유지형 보철 제작
- > 회전방지 단면 부여
- > Shoulder Ratchet Driver와 Torque Wrench를 사용하여 체결
- > 권장 체결 토크 : 30Ncm
- > Abutment level impression

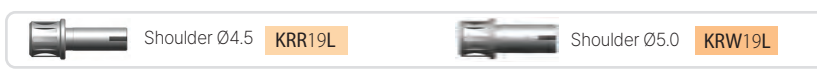

Solid/Shoulder Protection Cap



Shoulder Abutment Diameter	Ø3.5	Ø4.5
Diameter	Ø5.4	Ø5.4
Height		
6.2	IASR140	IASW140
7.7	IASR155	IASW155
9.2	IASR170	IASW170

- > 포장단위 : 1 Solid/Shoulder Protection Cap
- > 치유기간 중 구강 내 Abutment를 보호하고 환자의 이물감을 최소화
- > Abutment의 보철 마진을 형성하기 위한 Gingival retraction에 사용
- > 임시 보철의 하부구조로 사용 가능

Solid/Shoulder Impression Cap

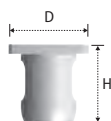

Shoulder Abutment Diameter	Ø3.5	Ø4.5
Diameter	8	9
Height		
8	IICR001	IICW001

- > 포장단위 : 1 Solid/Shoulder Impression Cap
- > Positioning Cylinder를 체결하여 인상 채득에 사용
- > 좌우로 회전하여 정확히 체결 되었는지 확인

Shoulder Positioning Cylinder

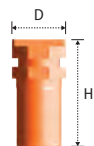

Shoulder Abutment Diameter	Ø3.5	Ø4.5
Diameter	5.7	6.8
Height		
10.7	SAPR001	SAPW001

- > 포장단위 : 1 Shoulder Positioning Cylinder
- > Abutment의 회전을 방지하기 위한 내부 단면 부여
- > Impression Cap에 체결

Shoulder Lab Analog

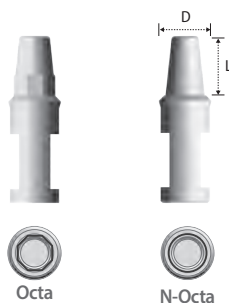

Type	Octa		N-Octa	
Shoulder Abutment Diameter	Ø3.5	Ø4.5	Ø3.5	Ø4.5
Diameter	Ø4.8	Ø5.9	Ø4.8	Ø5.9
Length				
4	SLCR040	SLCW040	SLBR040	SLBW040
5.5	SLCR055	SLCW055	SLBR055	SLBW055
7	SLCR070	SLCW070	SLBR070	SLBW070

- > 포장단위 : 1 Shoulder Lab Analog
- > Abutment analog로 작업모형 상에 Abutment 형상 구현
- > 사용 Abutment에 따라 선택

Prosthetic Procedure IV

Component Selection Guide for Ball Abutment

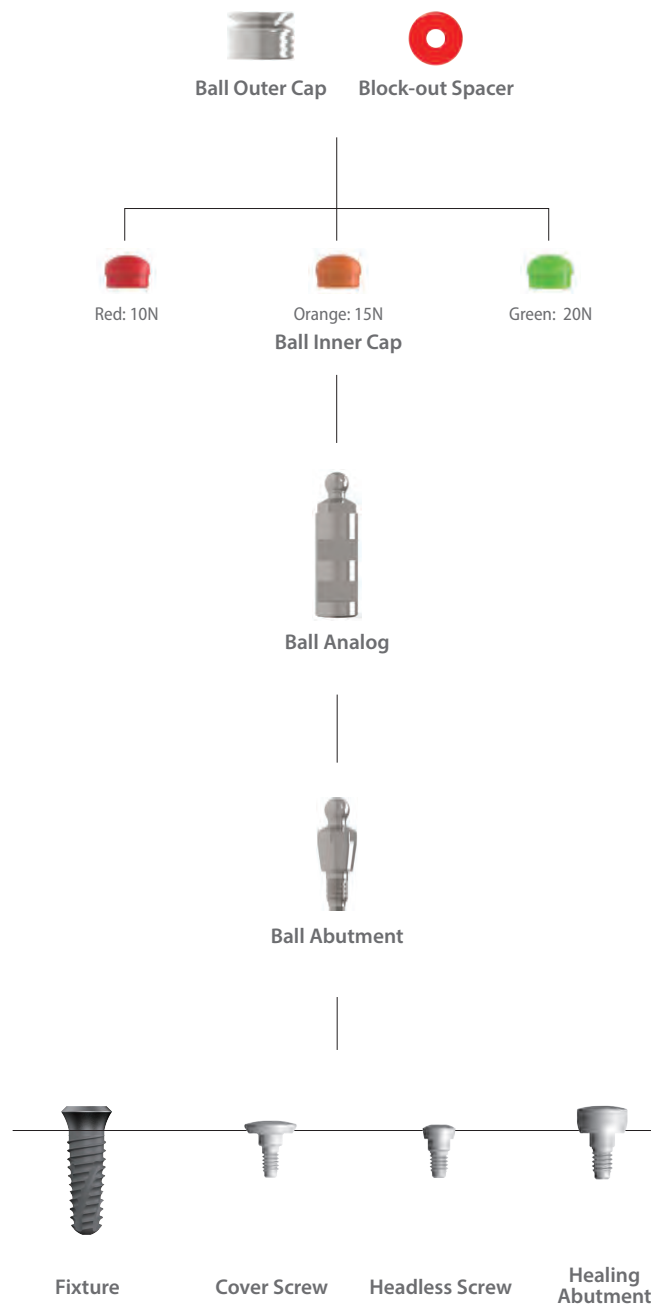

Ball Abutment

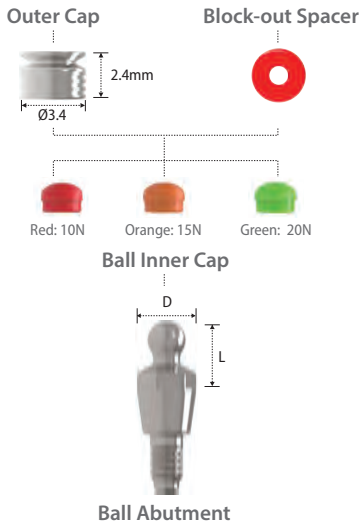

<i>Diameter</i>	Ø3.5
<i>Length</i>	4
IBAT404R	

- > 포장단위 : 1 Ball Abutment + 3 Inner Caps(유지력별 각 1개) + 1 Block-out Spacer + 1 Outer Cap
- > Implant supported ARP(Attachment Retained Prosthesis) 유지형 보철 제작
- > Ball Ratchet Driver와 Torque Wrench를 사용하여 체결
- > 권장 체결 토크 : 30Ncm
- > Direct impression

Ball Outer Cap

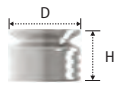

<i>Diameter</i>	Ø3.4
<i>Height</i>	2.6
BATC003C	

- > 포장단위 : 2 Outer Caps

Ball Inner Cap

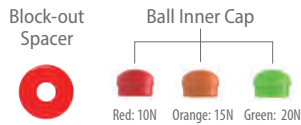

BATC003I	
----------	--

- > 포장단위 : 2 Block-out Spacers + 6 Inner Caps (유지력별 각 2개)
- > 유지력 : 10N, 15N, 20N

Ball Analog



<i>Diameter</i>	Ø4.0
<i>Length</i>	4
SBAL400	

- > 포장단위 : 4 Ball Lab Analogs
- > Abutment analog로 작업모형 상에 Abutment 형상 구현

Ball Ratchet Driver

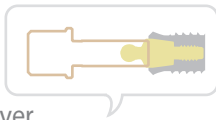
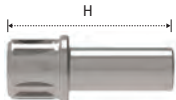

<i>Height</i>	19	<i>Type</i>	Ratchet
		KRB19L	

- > 포장단위 : 1 Ball Ratchet Driver *Extra Product
- > Torque Wrench를 사용하여 Ball Abutment 체결

Ball I&R Driver



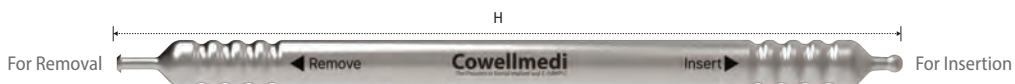



<i>Height</i>	100
KBIR01	

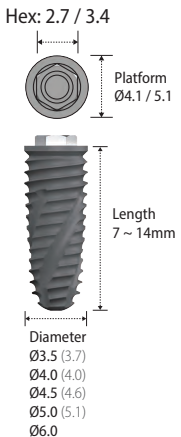

- > 포장단위 : 1 Ball I&R Driver
- > Inner Cap 삽입 및 제거 시 사용

INNO EXTERNAL IMPLANT (Ext.)

System Flow

Fixture	Abutment	
 <p>Hex: 2.7 / 3.4</p> <p>Platform Ø4.1 / 5.1</p> <p>Length 7 ~ 14mm</p> <p>Diameter Ø3.5 (3.7) Ø4.0 (4.0) Ø4.5 (4.6) Ø5.0 (5.1) Ø6.0</p>	Prosthetic Procedure I	<div style="display: flex; justify-content: space-around; align-items: center;"> <div style="text-align: center;">  Cemented Abutment </div> <div style="text-align: center;">  Angulated Abutment </div> </div> <div style="display: flex; justify-content: space-around; align-items: center; margin-top: 20px;"> <div style="text-align: center;">  Temporary Abutment </div> <div style="text-align: center;">  Meta G UCLA Abutment </div> <div style="text-align: center;">  Plastic UCLA Abutment </div> </div>
	Prosthetic Procedure II	 Shoulder Abutment
	Prosthetic Procedure III	 Ball Abutment

	Impression			
Abutment Level Impression	 Solid/Shoulder Protection Cap	 Solid/Shoulder Impression Cap	 Shoulder Positioning Cylinder	 Shoulder Lab Analog
	 Ball Analog			
Fixture Level Impression	 Replica	 Pick-up Squared Impression Coping	 Transfer Post	

INNO External Implant (Ext.)



External Fixture
Surface Treatment: **SLA-SH**

- > Interchangeable with external hexagonal fixture.
- > External hex connection (Hex 2.7 / 3.4).

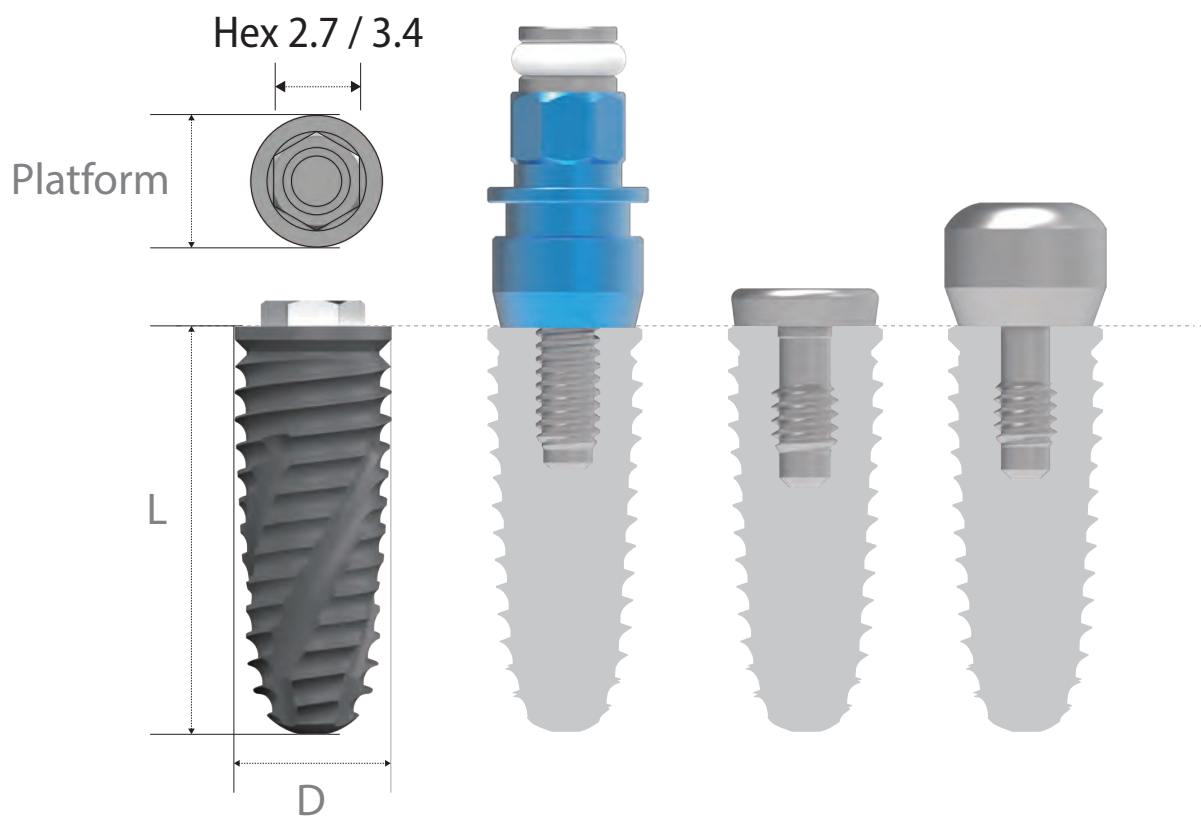

INNO Fixture Code

E	T	40	10	S	<input type="checkbox"/>
Type External	body Taper	Diameter Ø 4.0	Length 10mm	Surface Treatment SLA	Mount Pre-Mount

*Ex.)
SLA Pre-Mount **ET4010S**

Pre-Mount > 포장단위: 1 Fixture + 1 Mount + 1 Mount Screw

* Diameter (실직경) **Ø3.5 (Ø3.7)**

Length

7	-
8	ET3508S
10	ET3510S
12	ET3512S
14	ET3514S

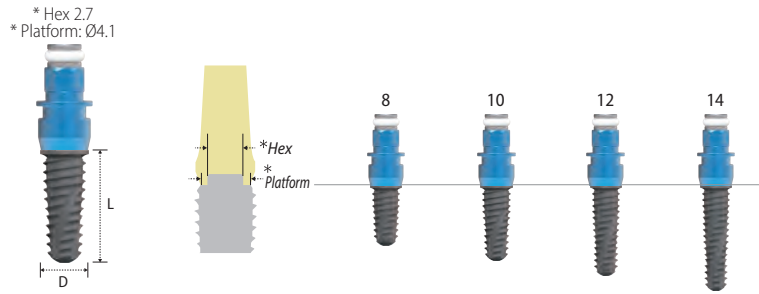

* Diameter (실직경) **Ø4.0 (Ø4.2)**

Length

7	ET4007S
8	ET4008S
10	ET4010S
12	ET4012S
14	ET4014S

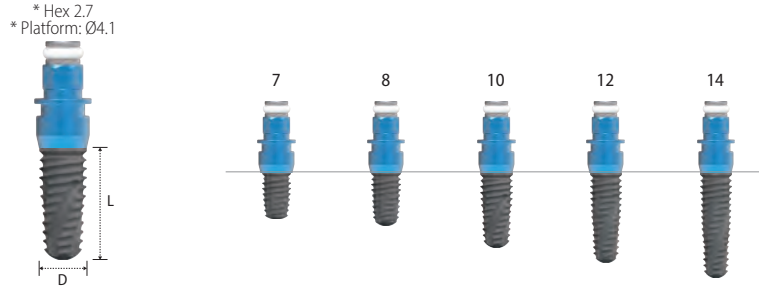

* Diameter (실직경) **Ø4.5 (Ø4.6)**

Length

7	ET4507S
8	ET4508S
10	ET4510S
12	ET4512S
14	ET4514S

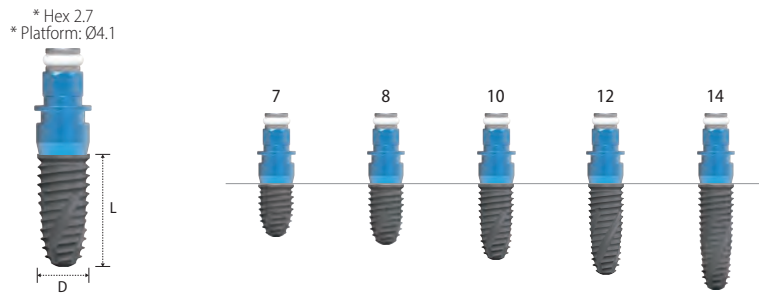

* Diameter (실직경) **Ø5.0 (Ø5.1)**

Length

7	ET5007S
8	ET5008S
10	ET5010S
12	ET5012S
14	ET5014S

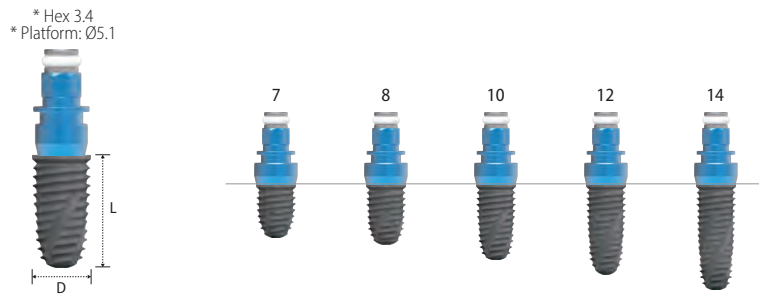

* Diameter (실제 길이) **Ø6.0**

Length

7	ET6007S
8 (7.5)	ET6008S
10 (9.5)	ET6010S
12 (11.5)	ET6012S
14	-

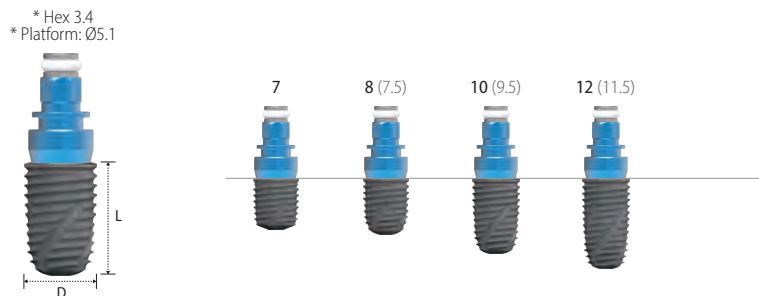

Fixture Mount

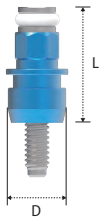

Hex	Hex2.7	Hex3.4
Platform [Fixture Dia.]	Ø4.1 [Ø3.5 / Ø4.0 / Ø4.5]	Ø5.1 [Ø5.0 / Ø6.0]
Diameter	Ø4.6	Ø5.5
Length	7.2	7.2
	MER001	MEW002

- > 포장단위 : 1 Mount + 1 Mount Screw
- > Hex Driver를 사용하여 체결
- > 권장 체결 토크 : 5~10Ncm

Cover Screw

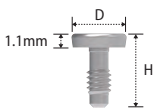

Hex	Hex2.7	Hex3.4
Platform [Fixture Dia.]	Ø4.1 [Ø3.5 / Ø4.0 / Ø4.5]	Ø5.1 [Ø5.0 / Ø6.0]
Diameter	Ø4.3	Ø5.4
Height	5.8	5.8
	VNR001	VNW001

- > 포장단위 : 1 Cover Screw
- > Fixture 식립 후 Fixture connection 보호
- > Hex Driver를 사용하여 체결
- > 권장 체결 토크 : 5~10Ncm

Healing Abutment

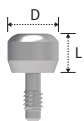

Hex	Hex2.7	Hex3.4
Platform [Fixture Dia.]	Ø4.1 [Ø3.5 / Ø4.0 / Ø4.5]	Ø5.1 [Ø5.0 / Ø6.0]
Diameter	Ø5.0 *(Ø4.95)	Ø6.0 *(Ø5.95)
Length	2	2
	HNR502	HNW602
	3	3
	HNR503	HNW603
	4	4
	HNR504	HNW604
	5	5
	HNR505	HNW605
	6	6
	HNR506	HNW606
	7	7
	HNR507	HNW607

*실직경

- > 포장단위 : 1 Healing Abutment
- > 치유기간 동안 Fixture에 체결하여 치은 형태 형성
- > Fixture platform, 치은 높이 및 사용 Abutment에 따라 선택 사용
- > Hex Driver를 사용하여 체결
- > 권장 체결 토크 : 5~10Ncm

Prosthetic Procedure I

Component Selection Guide for Cemented & UCLA Abutment

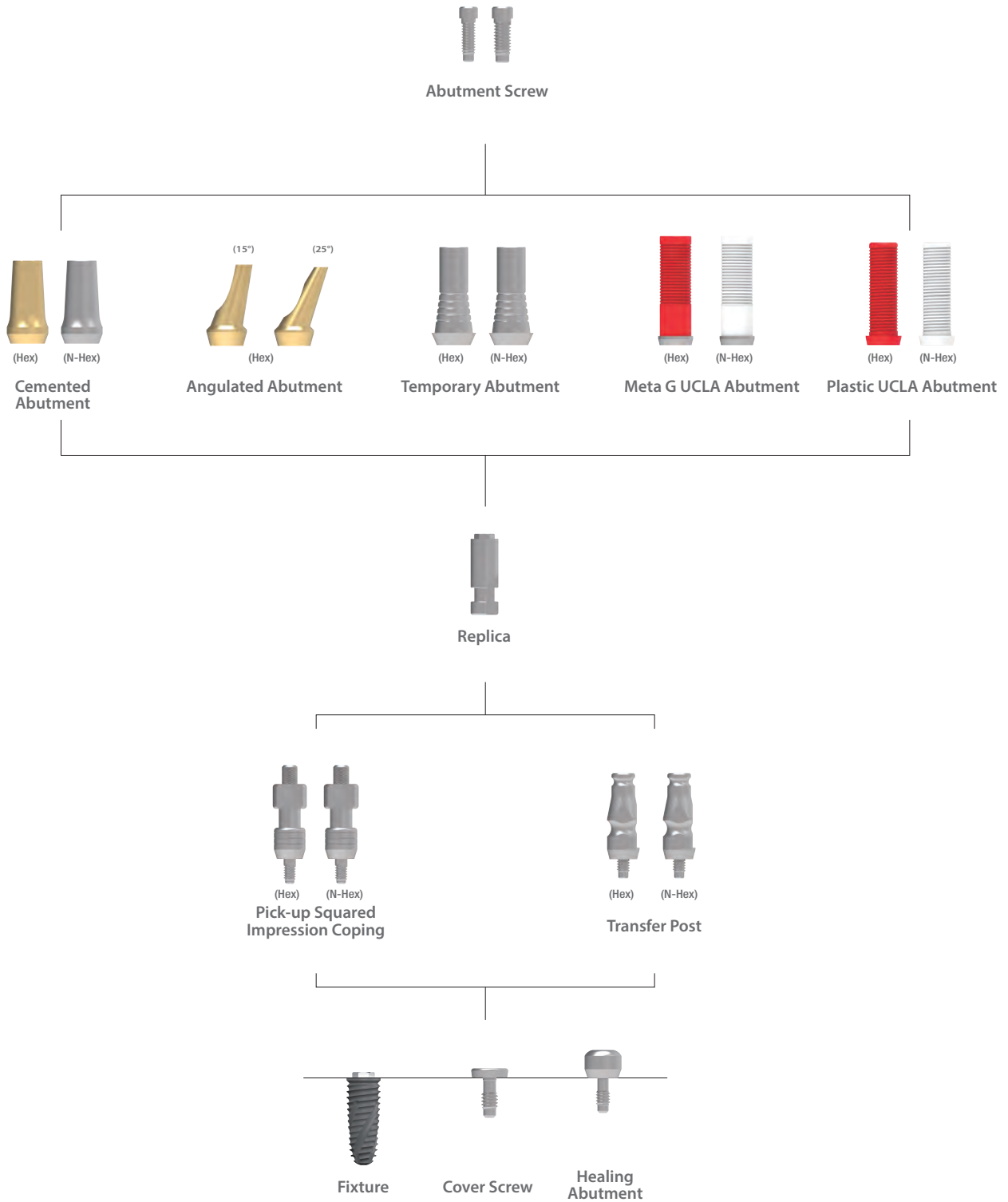

*실직경

Cemented Abutment

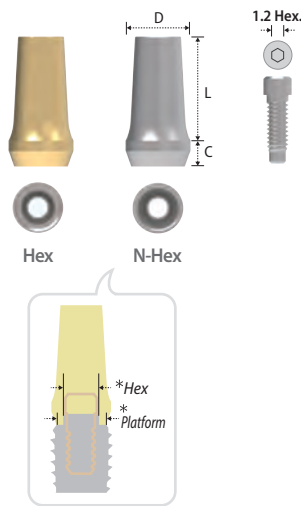

* Type[Hex]	Hex[2.7]		Hex[3.4]	
* Platform [Fixture Dia.]	Ø4.1 [Ø3.5 / Ø4.0 / Ø4.5]		Ø5.1 [Ø5.0 / Ø6.0]	
Diameter	Ø5.0 *(Ø4.95)		Ø6.0 *(Ø5.95)	
Length Cuff	6	8	6	8
	1	CHR516	CHR518	CHW616
2	CHR526	CHR528	CHW626	CHW628
3	CHR536	CHR538	CHW636	CHW638
4	CHR546	CHR548	CHW646	CHW648

Type[Hex]	N-Hex			
Platform [Fixture Dia.]	Ø4.1 [Ø3.5 / Ø4.0 / Ø4.5]		Ø5.1 [Ø5.0 / Ø6.0]	
Diameter	Ø5.0 *(Ø4.95)		Ø6.0 *(Ø5.95)	
Length Cuff	6	8	6	8
	1	CNR516	CNR518	CNW616
2	CNR526	CNR528	CNW626	CNW628
3	CNR536	CNR538	CNW636	CNW638
4	CNR546	CNR548	CNW646	CNW648

- > 포장단위 : 1 Cemented Abutment + 1 Abutment Screw(SHR100 / SHW100)
- > CRP 및 SCRП 유지형 보철 제작
- > 회전방지 단면 부여
- > Hex Driver와 Torque Wrench를 사용하여 체결
- > 권장 체결 토크 : 30Ncm
- > Fixture level impression

Angulated Abutment

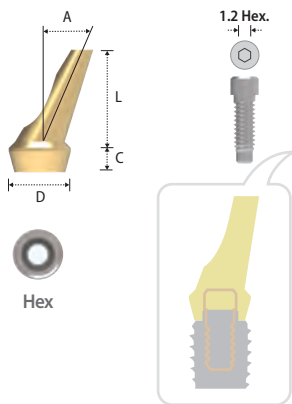

Type[Hex]	Hex[2.7]	Hex[3.4]	Hex[2.7]	Hex[3.4]
Platform [Fixture Dia.]	Ø4.1 [Ø3.5 / Ø4.0 / Ø4.5]	Ø5.1 [Ø5.0 / Ø6.0]	Ø4.1 [Ø3.5 / Ø4.0 / Ø4.5]	Ø5.1 [Ø5.0 / Ø6.0]
Diameter (Angle)	Ø5 (15°)	Ø6 (15°)	Ø5 (25°)	Ø6 (25°)
Length Cuff	8	8	8	8
	2	AAR152	AAW152	AAR252
3	AAR153	AAW153	AAR253	AAW253
4	AAR154	AAW154	AAR254	AAW254

- > 포장단위 : 1 Angulated Abutment + 1 Abutment Screw(SHR100 / SHW100)
- > CRP 유지형 보철 제작
- > Fixture path를 보상(최대 25°) 및 전치부에 사용
- > Hex Driver와 Torque Wrench를 사용하여 체결
- > 권장 체결 토크 : 30Ncm
- > Fixture level impression

Temporary Abutment

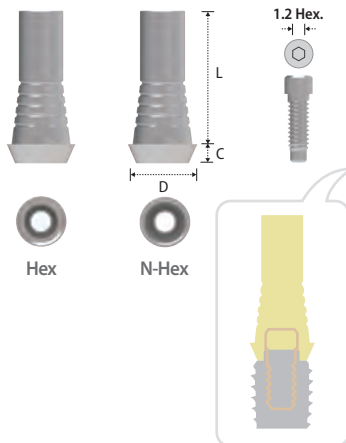

Type[Hex]	Hex[2.7]	Hex[3.4]	N-Hex	N-Hex
Platform [Fixture Dia.]	Ø4.1 [Ø3.5 / Ø4.0 / Ø4.5]	Ø5.1 [Ø5.0 / Ø6.0]	Ø4.1 [Ø3.5 / Ø4.0 / Ø4.5]	Ø5.1 [Ø5.0 / Ø6.0]
Diameter	Ø5.4	Ø5.95	Ø5.4	Ø5.95
Length Cuff	12	12	12	12
	1.5	THR001	THW001	TNR001

- > 포장단위 : 1 Temporary Abutment + 1 Abutment(SHR100 / SHW100)
- > CRP, SRP 및 SCRП 유지형 임시 보철 제작
- > Resin 탈락 방지를 위한 Groove 부여
- > Hex Driver와 Torque Wrench를 사용하여 체결
- > 권장 체결 토크 : 30Ncm
- > Fixture level impression

Meta G UCLA Abutment

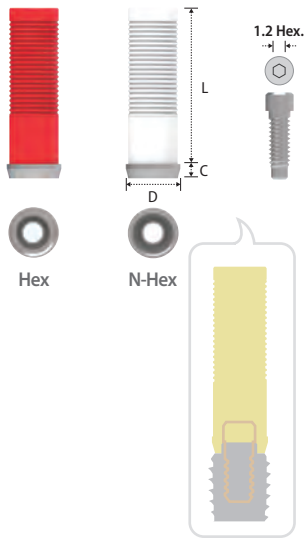

Type[Hex]	Hex[2.7]	Hex[3.4]	N-Hex	N-Hex
Platform [Fixture Dia.]	Ø4.1 [Ø3.5 / Ø4.0 / Ø4.5]	Ø5.1 [Ø5.0 / Ø6.0]	Ø4.1 [Ø3.5 / Ø4.0 / Ø4.5]	Ø5.1 [Ø5.0 / Ø6.0]
Diameter	Ø4.5	Ø5.5	Ø4.5	Ø5.5
Length Cuff	13	13	13	13
1.2	GHR001N	GHW001N	GNR001N	GNW001N

- > 포장단위 : 1 Meta G UCLA Abutment + 1 Abutment Screw(SHR100 / SHW100)
- > CRP, SRP 및 SCRП 유지형 보철 제작
- > Path 조정, 심미 등을 위한 Customizing이 필요한 경우에 사용
- > 비귀금속 합금을 사용하여 Casting하여 보철물 제작
- > Metal base로 Connection부의 정밀도가 높음
- > Hex Driver와 Torque Wrench를 사용하여 체결
- > 권장 체결 토크 : 30Ncm
- > Fixture level impression

Plastic UCLA Abutment

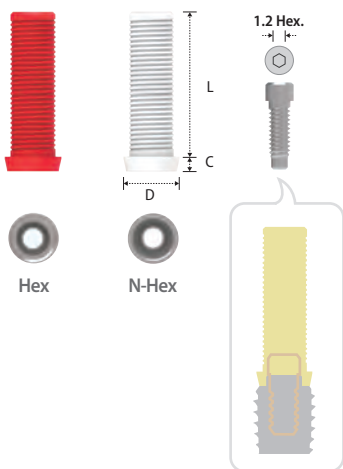

Type[Hex]	Hex[2.7]	Hex[3.4]	N-Hex	N-Hex
Platform [Fixture Dia.]	Ø4.1 [Ø3.5 / Ø4.0 / Ø4.5]	Ø5.1 [Ø5.0 / Ø6.0]	Ø4.1 [Ø3.5 / Ø4.0 / Ø4.5]	Ø5.1 [Ø5.0 / Ø6.0]
Diameter	Ø4.5	Ø5.5	Ø4.5	Ø5.5
Length Cuff	11.8	11.8	11.8	11.8
1.2	PHR001	PHW001	PNR001	PNW001

- > 포장단위 : 1 Plastic UCLA Abutment + 1 Abutment Screw(SHR100 / SHW100)
- > Meta G UCLA Abutment와 같은 용도로 사용하나 Connection부의 정밀도가 떨어짐
- > 권장 체결 토크 : Casting 전 20Ncm이하, Casting 후 30Ncm

Abutment Screw

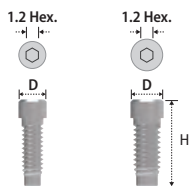

Type[Hex]	Hex[2.7]	Hex[3.4]
Platform [Fixture Dia.]	Ø4.1 [Ø3.5 / Ø4.0 / Ø4.5]	Ø5.1 [Ø5.0 / Ø6.0]
Diameter Height	Ø2.5	Ø3.0
8	SHR100	SHW100

- > 포장단위 : 1 Abutment Screw
- > Hex Driver와 Torque Wrench를 사용하여 체결

Replica



Type[Hex]	Hex[2.7]	Hex[3.4]
Platform [Fixture Dia.]	Ø4.1 [Ø3.5 / Ø4.0 / Ø4.5]	Ø5.1 [Ø5.0 / Ø6.0]
Diameter / Height	Ø4.1	Ø5.1
	LHR001	LHW001

- > 포장단위 : 1 Replica
- > Fixture analog로 작업모형 상에 Fixture 형상 구현

Pick-up Squared Impression Coping

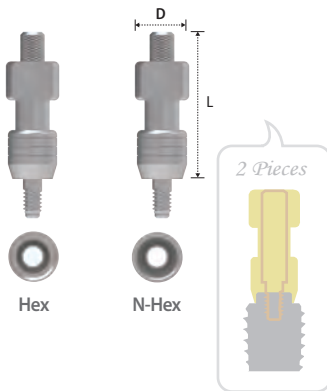

Type[Hex]	Hex[2.7]	Hex[3.4]	N-Hex	N-Hex
Platform [Fixture Dia.]	Ø4.1 [Ø3.5 / Ø4.0 / Ø4.5]	Ø5.1 [Ø5.0 / Ø6.0]	Ø4.1 [Ø3.5 / Ø4.0 / Ø4.5]	Ø5.1 [Ø5.0 / Ø6.0]
Diameter / Length	Ø5.0	Ø5.8	Ø5.0	Ø5.8
	IHR500	IHW600	INR500	INW600

- > 포장단위 : 1 Pick-up Impression Coping + 1 Guide Pin(UHR115 / UHW115)
- > Open tray 사용(Custom tray)
- > Hex Driver를 사용하여 체결
- > 권장 체결 토크 : 12~15Ncm
- > Fixture level impression

Transfer Post

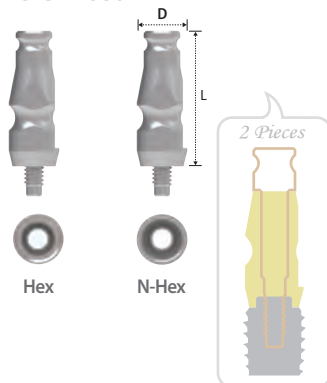

Type[Hex]	Hex[2.7]	Hex[3.4]	N-Hex	N-Hex
Platform [Fixture Dia.]	Ø4.1 [Ø3.5 / Ø4.0 / Ø4.5]	Ø5.1 [Ø5.0 / Ø6.0]	Ø4.1 [Ø3.5 / Ø4.0 / Ø4.5]	Ø5.1 [Ø5.0 / Ø6.0]
Diameter / Length	Ø4.8	Ø5.8	Ø4.8	Ø5.8
	IHR510	IHW610	INR510	INW610

- > 포장단위 : Octa - 1 Transfer Post + 1 Guide Pin(IHR510S / IHW610S)
- > Closed tray 사용
- > Hex Driver를 사용하여 체결
- > 권장 체결 토크 : 12~15Ncm
- > Fixture level impression

Prosthetic Procedure II

Component Selection Guide for Shoulder Abutment

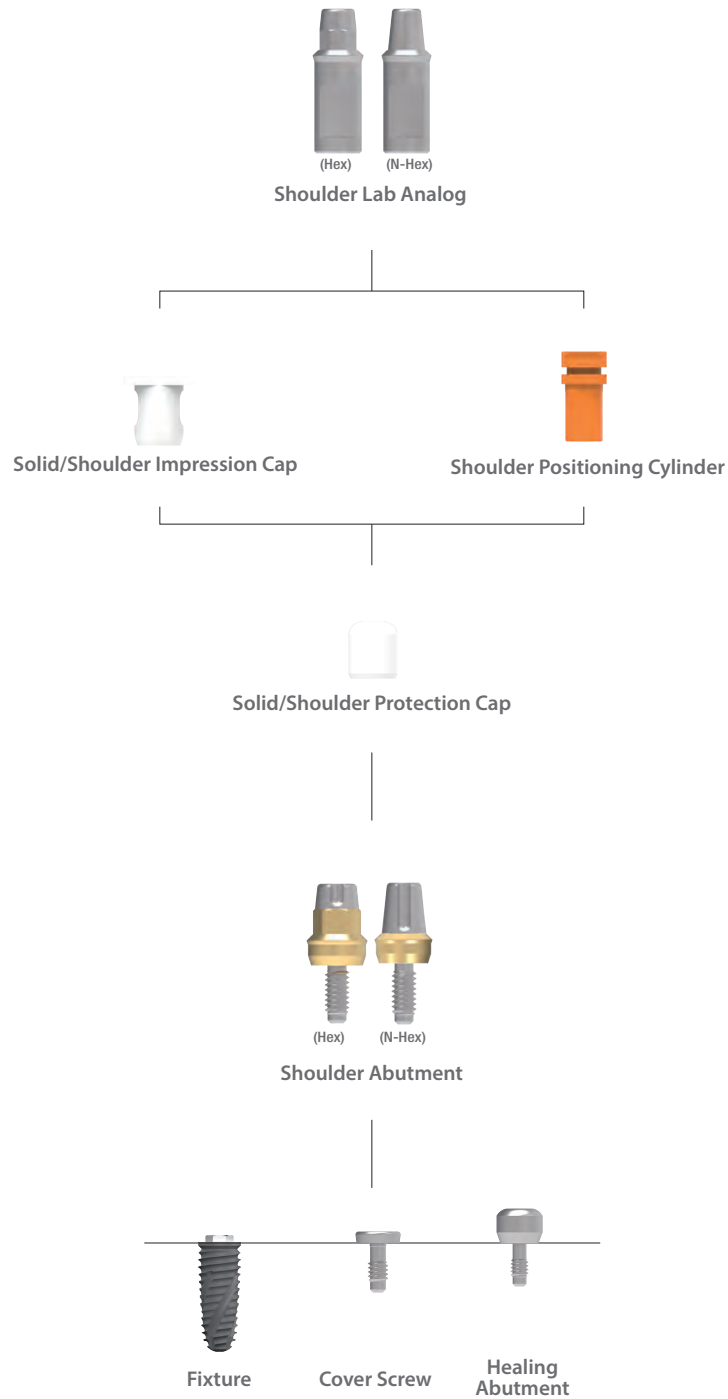

Shoulder Abutment

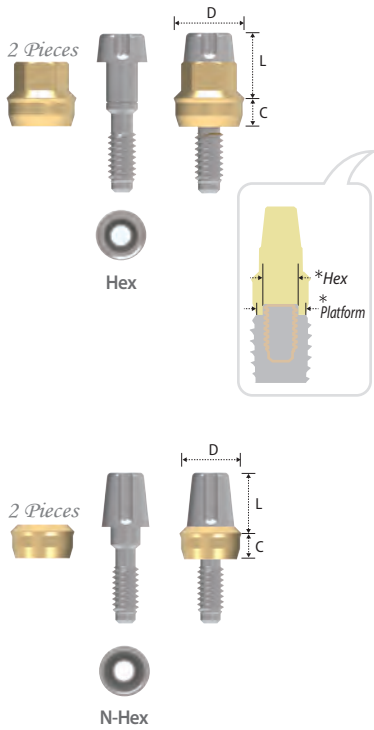

Type[Hex]	Hex[2.7]			Hex[3.4]		
* Platform [Fixture Dia.]	Ø4.1 [Ø3.5 / Ø4.0 / Ø4.5]			Ø5.1 [Ø5.0 / Ø6.0]		
Diameter	Ø4.8			Ø5.9		
Length Cuff	4	5.5	7	4	5.5	7
1	SAC414	SAC415	SAC417	SAC514	SAC515	SAC517
2	SAC424	SAC425	SAC427	SAC524	SAC525	SAC527
3	SAC434	SAC435	SAC437	SAC534	SAC535	SAC537
4	SAC444	SAC445	SAC447	SAC544	SAC545	SAC547

Type[Hex]	N-Hex			N-Hex		
* Platform [Fixture Dia.]	Ø4.1 [Ø3.5 / Ø4.0 / Ø4.5]			Ø5.1 [Ø5.0 / Ø6.0]		
Diameter	Ø4.8			Ø5.9		
Length Cuff	4	5.5	7	4	5.5	7
1	SAB414	SAB415	SAB417	SAB514	SAB515	SAB517
2	SAB424	SAB425	SAB427	SAB524	SAB525	SAB527
3	SAB434	SAB435	SAB437	SAB534	SAB535	SAB537
4	SAB444	SAB445	SAB447	SAB544	SAB545	SAB547

- > 포장단위 : 1 Solid Abutment(Solid type) + 1 Protection Cap
- > CRP 유지형 보철 제작
- > 회전방지 단면 부여
- > Shoulder Ratchet Driver와 Torque Wrench를 사용하여 체결
- > 권장 체결 토크: 30Ncm
- > Abutment level impression
- > Platform Ø4.1 Fixture(Ø3.5, 4.0, 4.5): Impression Cap 사용 인상 채득
- > Platform Ø5.1 Fixture(Ø5.0, 6.0): Direct impression

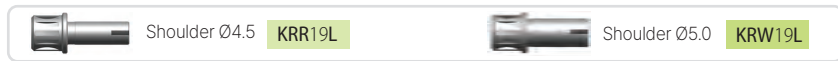

Solid/Shoulder Protection Cap

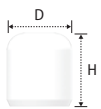

Shoulder Abutment Diameter	Ø4.8	Ø5.9
Diameter	Ø5.4	Ø6.5
Height	6.2	7.7
	IASR140	IASW140
	IASR155	IASW155
	IASR170	IASW170

- > 포장단위 : 1 Solid/Shoulder Protection Cap
- > 치유기간 중 구강 내 Abutment를 보호하고 환자의 이물감을 최소화
- > Abutment의 보철 마진을 형성하기 위한 Gingival retraction에 사용
- > 임시 보철의 하부구조로 사용 가능

Solid/Shoulder Impression Cap

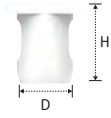

Shoulder Abutment Diameter	Ø4.8	Ø5.9
Diameter	8	9
Height	8	IICR001
		IICW001

- > 포장단위 : 1 Solid/Shoulder Impression Cap
- > Positioning Cylinder를 체결하여 인상 채득에 사용
- > 좌우로 회전하여 정확히 체결 되었는지 확인

Shoulder Positioning Cylinder

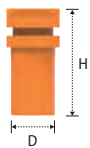

Shoulder Abutment Diameter	Ø4.8	Ø5.9
Diameter	Ø4.4	Ø5.5
Height	10.7	SAPR001
		SAPW001

- > 포장단위 : 1 Shoulder Positioning Cylinder
- > Abutment의 회전을 방지하기 위한 내부 단면 부여
- > Impression Cap에 체결

Shoulder Lab Analog

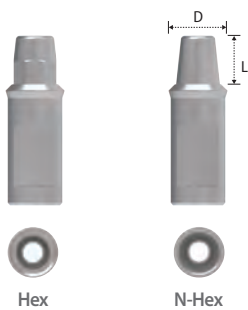

Type[Hex]	Hex[2.7&3.4]		N-Hex	
Shoulder Abutment Diameter	Ø4.8	Ø5.9	Ø4.8	Ø5.9
Diameter	Ø4.8	Ø5.9	Ø4.8	Ø5.9
Length	4	SLCR040	SLCW040	SLBR040
	5.5	SLCR055	SLCW055	SLBR055
	7	SLCR070	SLCW070	SLBR070
			SLBW040	SLBW055
			SLBW070	

- > 포장단위 : 1 Shoulder Lab Analog
- > Abutment analog로 작업모형 상에 Abutment 형상 구현
- > 사용 Abutment에 따라 선택

Prosthetic Procedure III

Component Selection Guide for Ball Abutment

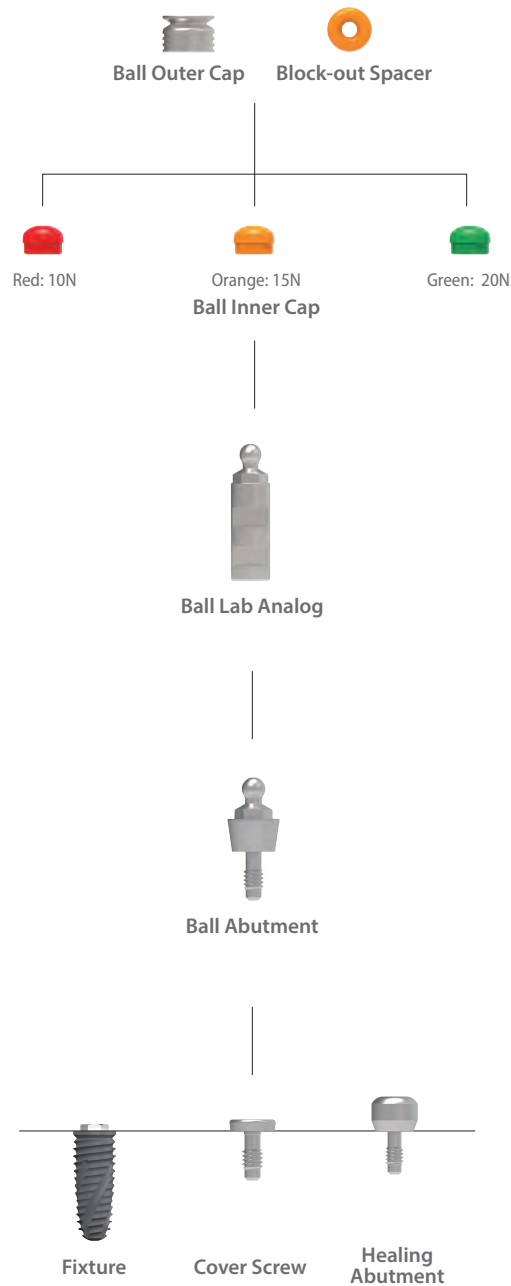

Ball Abutment

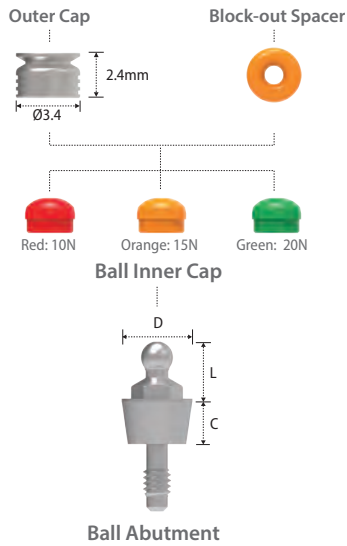

*실직경

Diameter	Ø5.0 *(Ø4.95)	Ø6.0 *(Ø5.95)
Length	4	4
Cuff		
1	EBAT411R	EBAT511R
2	EBAT412R	EBAT512R
3	EBAT413R	EBAT513R
4	EBAT414R	EBAT514R

- > 포장단위 : 1 Ball Abutment + 3 Inner Caps(유지력별 각 1개) + 1 Block-out Spacer + 1 Outer Cap
- > Implant supported ARP(Attachment Retained Prosthesis) 유지형 보철 제작
- > Ball Ratchet Driver와 Torque Wrench를 사용하여 체결
- > 권장 체결 토크 : 30Ncm
- > Direct impression

Ball Outer Cap

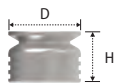

Diameter / Height	Ø3.4
2.6	BATC003C

- > 포장단위 : 2 Outer Caps

Ball Inner Cap

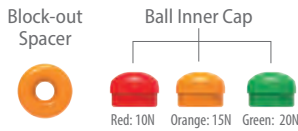

BATC003I	
----------	--

- > 포장단위 : 2 Block-out Spacers + 6 Inner Caps (유지력별 각 2개)
- > 유지력 : 10N, 15N, 20N

Ball Lab Analog



Diameter / Length	Ø4.0
4	SBAL400

- > 포장단위 : 4 Ball Lab Analogs
- > Abutment analog로 작업모형 상에 Abutment 형상 구현

Ball Ratchet Driver

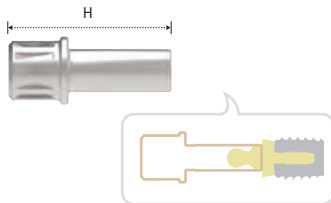

Type	Ratchet
Height	KRB19L
19	

- > 포장단위 : 1 Ball Ratchet Driver
- > Torque Wrench를 사용하여 Ball Abutment 체결

*Extra Product

Ball I&R Driver

Height	100
	KBIR01

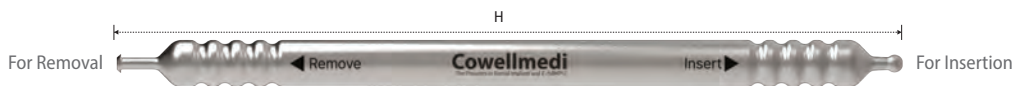

- > 포장단위 : 1 Ball I&R Driver
- > Inner Cap 삽입 및 제거 시 사용

Mini Plus Implant system

Mini Plus Implant

Cement Type

Ball Type

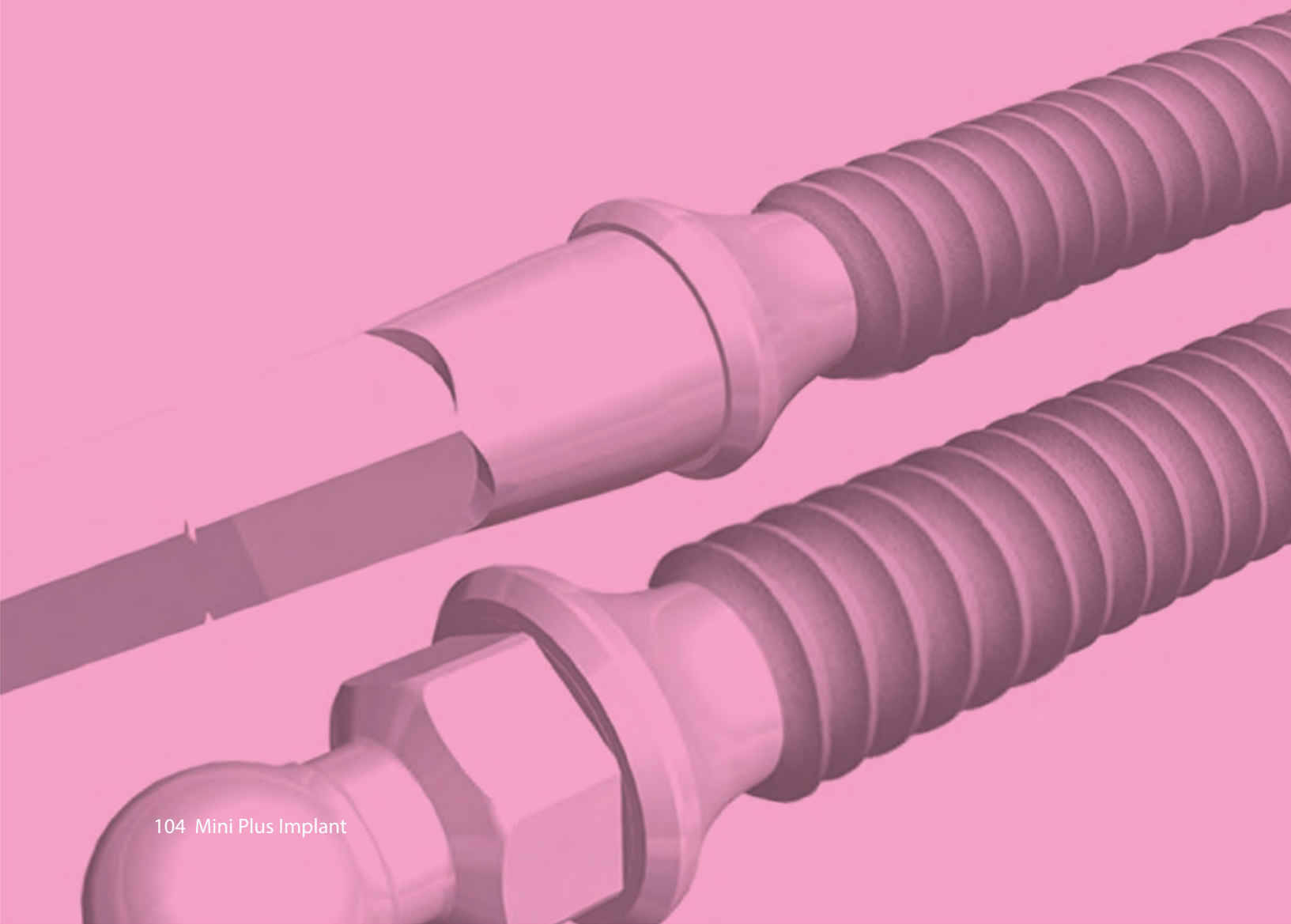

Mini Plus Implant System

DESIGN OF MINI PLUS FIXTURE (1P-C.)

Cement Type

- > 주로 좁은 하악 전치 및 무치악 환자에 Temporary implant로 사용
- > Permanent fixture 식립 전 임시 교합 또는 Bone graft를 지지할 목적으로 사용

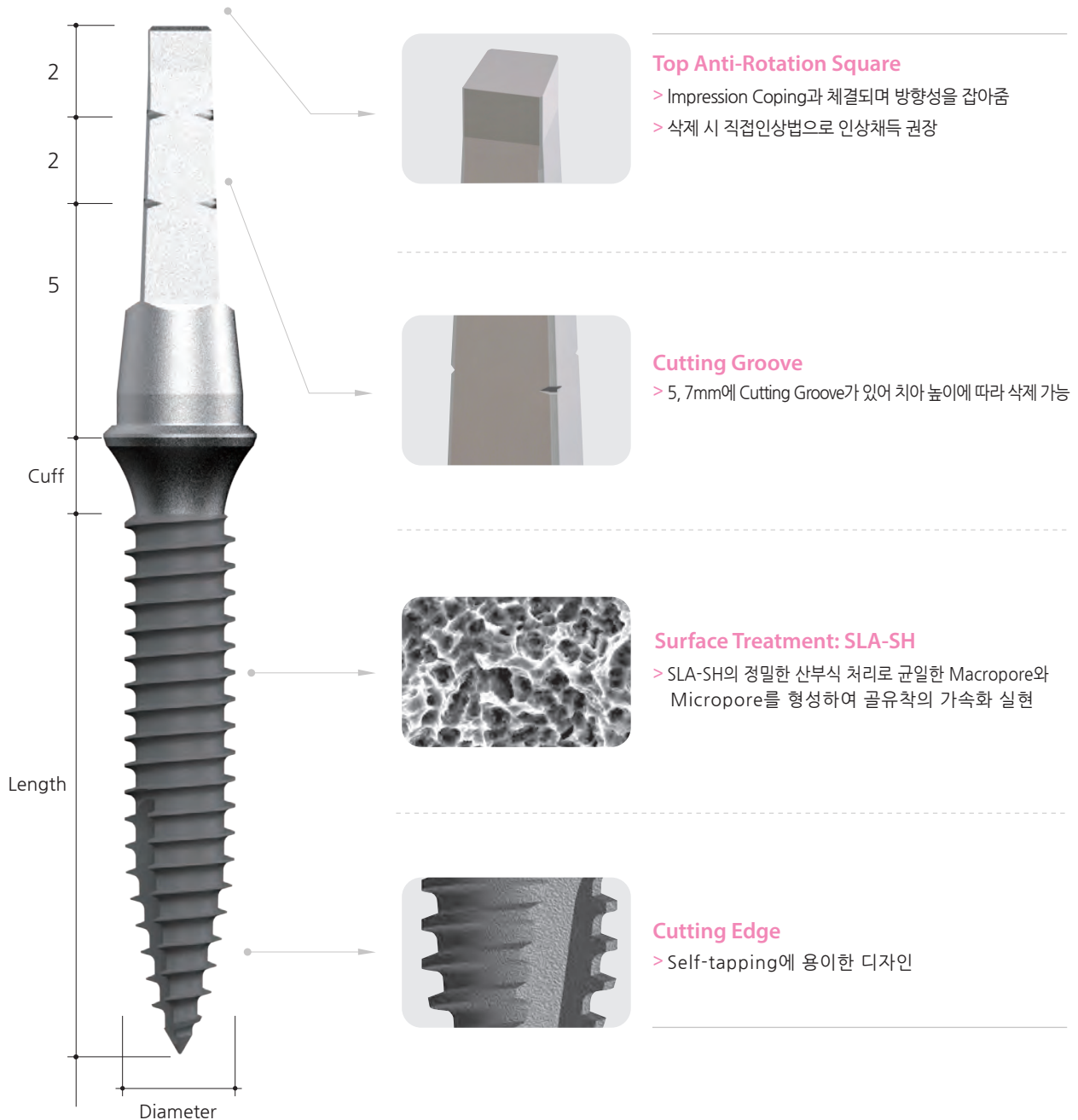

System Flow

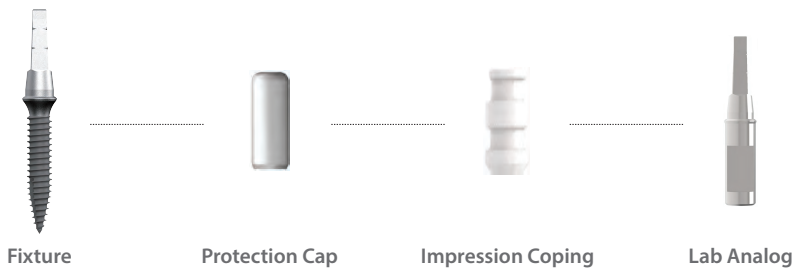

Fixture



Diameter		Ø2.5	
Length	Cuff	2.0mm	4.0mm
10mm		AMC2210S	AMC2410S
12mm		AMC2212S	AMC2412S
14mm		AMC2214S	AMC2414S

- > 포장단위 : 1 Fixture
- > Abutment level impression



Diameter		Ø3.0	
Length	Cuff	2.0mm	4.0mm
10mm		AMC3210S	AMC3410S
12mm		AMC3212S	AMC3412S
14mm		AMC3214S	AMC3414S

- > 포장단위 : 1 Fixture
- > Abutment level impression

Impression Coping / Lab Analog



Impression Coping

AMCI001



Lab Analog

AMCL001

Impression Coping

- > 포장단위 : 1 Impression Coping
- > Abutment의 Shoulder에 체결되며 인상 채득 후 Lab Analog에 체결하여 구강모델 제작에 사용
- > Abutment 삭제 시 직접 인상법으로 인상 채득

Lab Analog

- > 포장단위 : 1 Lab Analog
- > Impression Coping으로 채득된 Tray에 삽입하여 구강모델 제작 시 사용되는 Abutment 형상
- > Abutment 삭제 시 Abutment 형상과 동일한 삭제 권장

Protection Cap

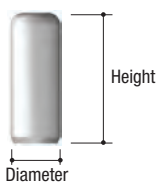

Diameter	Height	Ø4.0
7mm		AMCC001
9mm		AMCC002
11mm		AMCC003

- > 포장단위 : 1 Protection Cap
- > Fixture 식립 후 구강점막 및 혀를 보호하기 위하여 사용

DESIGN OF MINI PLUS FIXTURE (1P-B.)

Ball Type

> Temporary implant로 무치악 환자에 implant supported overdenture 제작 시 일정 기간 사용



System Flow

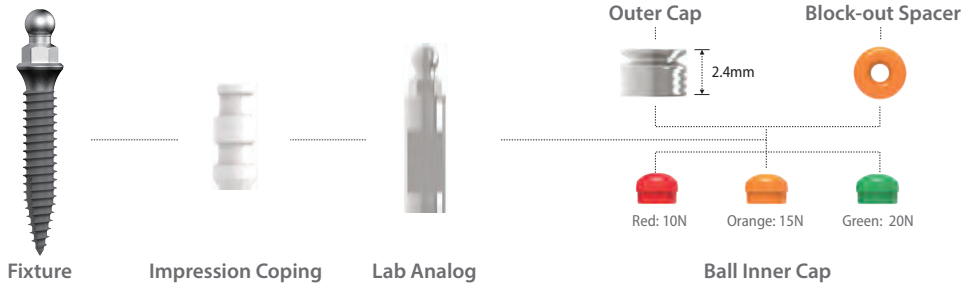

Fixture



Diameter	Ø2.5	
Length \ Cuff	2.0mm	4.0mm
10mm	AMB2210S	AMB2410S
12mm	AMB2212S	AMB2412S
14mm	AMB2214S	AMB2414S

- > 포장단위 : 1 Fixture
- > Abutment level impression



Diameter	Ø3.0	
Length \ Cuff	2.0mm	4.0mm
10mm	AMB3210S	AMB3410S
12mm	AMB3212S	AMB3412S
14mm	AMB3214S	AMB3414S

- > 포장단위 : 1 Fixture
- > Abutment level impression

Ball Outer Cap

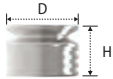

Diameter / Height	Ø3.4
2.4	BATC003C

- > 포장단위 : 2 Outer Caps

Ball Inner Cap

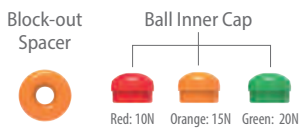

Code
BATC003I

- > 포장단위 : 2 Block-out Spacers + 6 Inner Caps (유지력별 각 2개)
- > 유지력 : 10N, 15N, 20N

Impression Coping / Lab Analog



Impression Coping
AMBI001



Lab Analog
AMBL001

Impression Coping

- > 포장단위 : 1 Impression Coping
- > Ball Post의 인상 채득을 위해 사용

Lab Analog

- > 포장단위 : 1 Lab Analog
- > Impression Coping으로 채득된 Tray에 삽입하여 구강모델 제작 시 사용되는 Abutment 형상

COWELL DIGITAL PRODUCTS

Drive Yourself to Cowellmedi's Digital Transformation

Digital Prosthesis

SFIT Cementless Solution(Spread-Fit)

- Sub. SFIT Ti-Base System
- Sub. Multi SFIT Ti-Base System
- Sub-N. SFIT Ti-Base
- Sub-N. Multi SFIT Ti-Base

Hybrid Solution

- Sub. Hybrid Ti-Base System
- Sub. Multi Hybrid Ti-Base System
- Sub-N. Hybrid Ti-Base System

Spread Fit™

SFIT Cementless Solution

SFIT, 보철의 날개를 펼칩니다

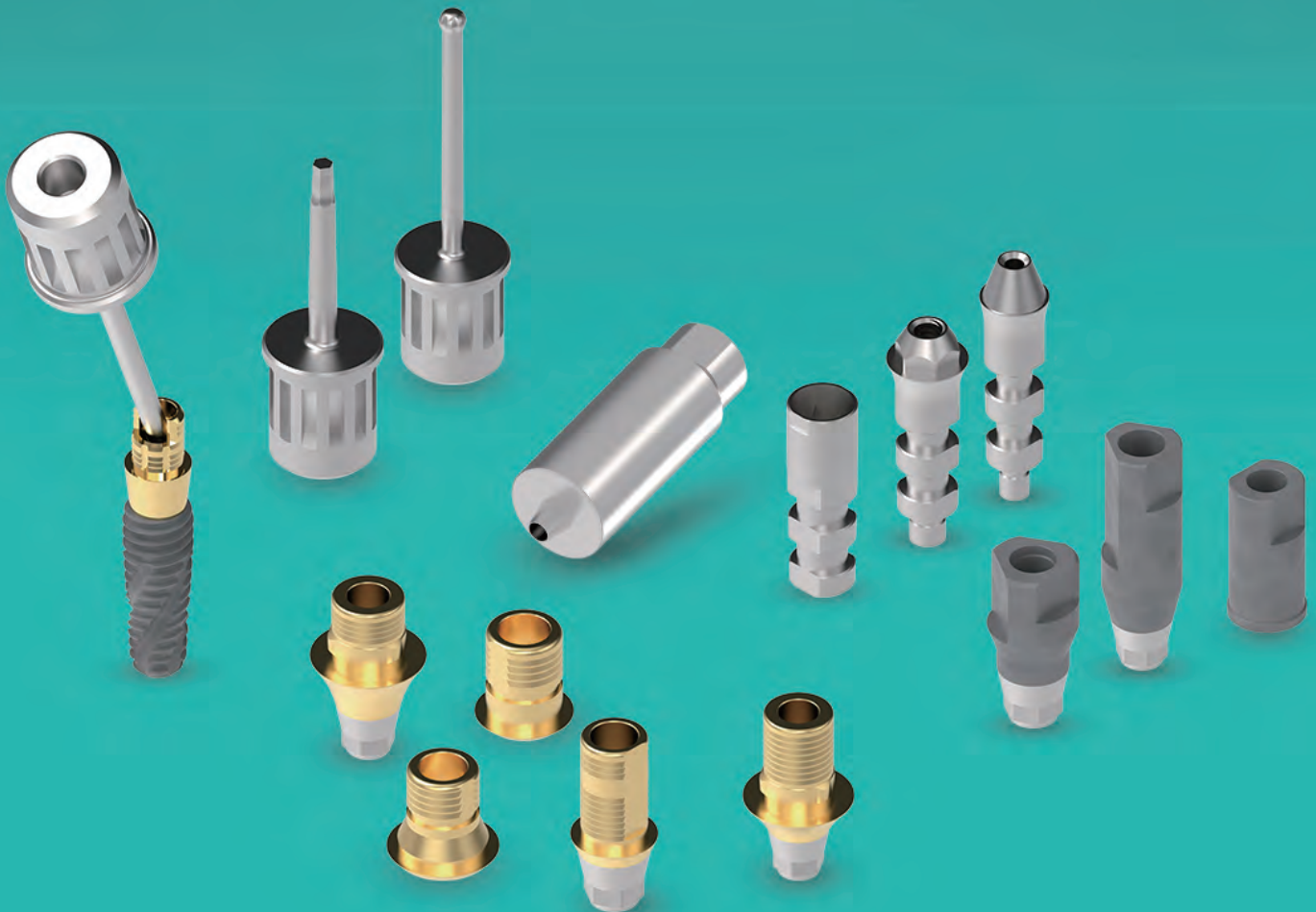

Component selection guide for the Sub. SFIT Ti-Base

- Intra-oral scanning
- Model scanning

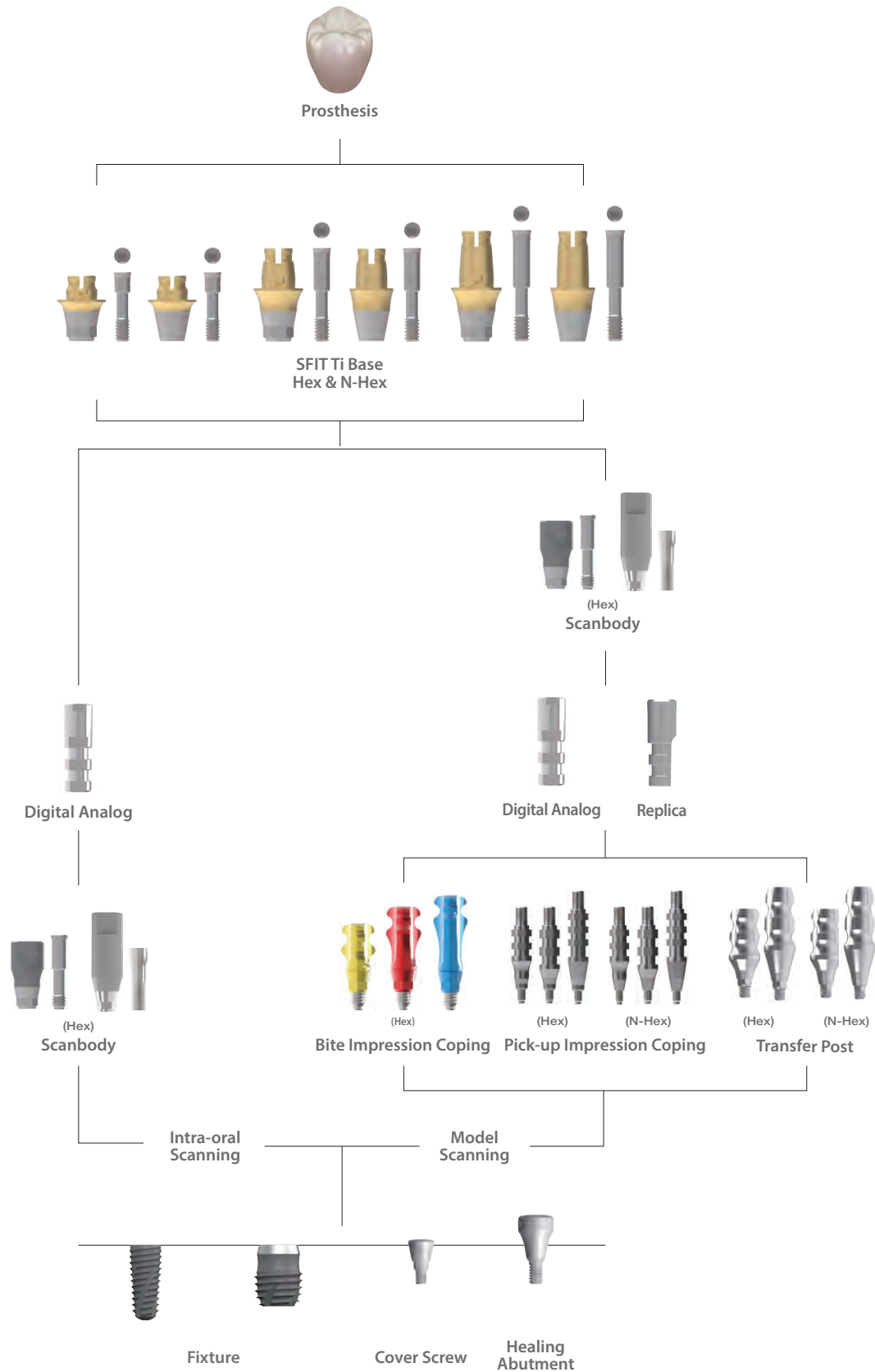

SFIT Ti-Base

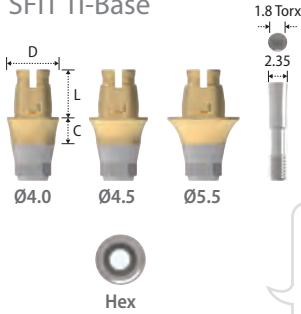

Type	Hex								
Length	2.2			3.6			5.0		
Cuff / Diameter	Ø4.0	Ø4.5	Ø5.5	Ø4.0	Ø4.5	Ø5.5	Ø4.0	Ø4.5	Ø5.5
0.5	-	2SSFH45020A	2SSFH5020A	-	-	-	-	-	-
1	-	2SSFH45120A	2SSFH5120A	2SSFH38135A	2SSFH45135A	2SSFH5135A	2SSFH38150A	2SSFH45150A	2SSFH5150A
2	-	2SSFH45220A	2SSFH5220A	2SSFH38235A	2SSFH45235A	2SSFH5235A	2SSFH38250A	2SSFH45250A	2SSFH5250A
3	-	2SSFH45320A	2SSFH5320A	2SSFH38335A	2SSFH45335A	2SSFH5335A	2SSFH38350A	2SSFH45350A	2SSFH5350A
4	-	-	-	2SSFH38435A	2SSFH45435A	2SSFH5435A	2SSFH38450A	2SSFH45450A	2SSFH5450A

- > 포장단위 : 1 SFIT Ti-Base + 1 SFIT Ti-Base Screw
- > Spread Fit™ 유지형 Cementless보철 제작으로 유지보수가 매우 용이
- > Angulated screw channel 형성 가능(최대 25°)
- > 극도로 짧은 치관 및 낮은 교합고경에서도 사용 가능
- > 심미성을 위한 Gold coloring 및 회전방지 돌기 부여
- > 3shape 및 Exocad용 라이브러리 제공(5µm 단위로 세분화)
- > Torx Driver와 Torque Wrench를 사용하여 체결
(Straight screw channel: Torx S Driver / Angulated screw channel: Torx A Driver)
- > 권장 체결 토크 : 35Ncm
- > Fixture level impression

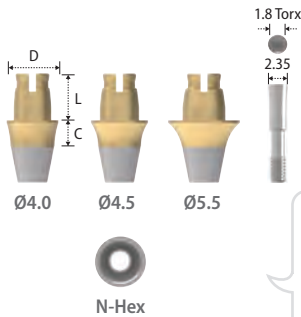

Type	N-Hex								
Length	2.2			3.6			5.0		
Cuff / Diameter	Ø4.0	Ø4.5	Ø5.5	Ø4.0	Ø4.5	Ø5.5	Ø4.0	Ø4.5	Ø5.5
0.5	-	2SSFN45020A	2SSFN5020A	-	-	-	-	-	-
1	-	2SSFN45120A	2SSFN5120A	2SSFN38135A	2SSFN45135A	2SSFN5135A	2SSFN38150A	2SSFN45150A	2SSFN5150A
2	-	2SSFN45220A	2SSFN5220A	2SSFN38235A	2SSFN45235A	2SSFN5235A	2SSFN38250A	2SSFN45250A	2SSFN5250A
3	-	2SSFN45320A	2SSFN5320A	2SSFN38335A	2SSFN45335A	2SSFN5335A	2SSFN38350A	2SSFN45350A	2SSFN5350A
4	-	-	-	2SSFN38435A	2SSFN45435A	2SSFN5435A	2SSFN38450A	2SSFN45450A	2SSFN5450A

- > Healing Abutment의 Size는 사용 될 SFIT Ti-Base의 직경보다 한 단계 큰 Size 권장
- > 잇몸 압박으로 인한 Ti-Base seating의 어려움 발생을 방지 및 올바른 Emergence profile 형성에 유리
ex) Ø4.5 SFIT Ti-Base 사용 시 Ø5.5 Healing Abutment 사용

SFIT Ti-Base Screw



Length / Cuff	2.2		3.6		5.0	
	Code	H	Code	H	Code	H
0.5	2SSFS05A20	8.4	-	-	-	-
1	2SSFS15A20	8.9	2SSFS10A35	10.6	2SSFS10A50	12
2	2SSFS25A20	9.9	2SSFS20A35	11.6	2SSFS20A50	13
3	2SSFS35A20	10.9	2SSFS30A53	12.6	2SSFS30A50	14
4	-	-	2SSFS40A35	13.6	2SSFS40A50	15

- > 포장단위 : 1 SFIT Ti-Base Screw
- > Angulated screw channel 형성 가능(최대 25°)
- > Torx S Driver 또는 Torx A Driver 와 Torque Wrench를 사용하여 체결

Scanbody

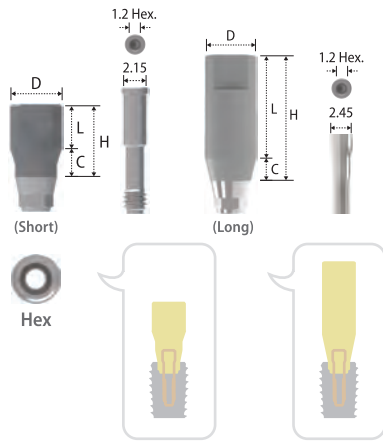

Type	Hex(Short)	Hex(Long)	
Diameter	Ø4.3	Ø4.3	
Height	6	11	
Length	4	9	
Cuff	2	2SSB4325	2SSB4329

- > 포장단위 : 1 Scanbody + 1 Abutment Screw(2SSB100S / 2SSHR100)
- > 내구성이 뛰어나고 정밀한 공차로 정확한 Digital impression(Scanning)
- > 특수 코팅적용한 100% 티타늄 합금
- > Scan spray 및 Sand Blasting등의 과정이 불필요
- > 개구량 부족 하지 않거나 교합고경이 충분하다면 Long Scanbody 사용 권장
- > Hex Driver를 사용하여 체결
- > 권장 체결 토크 : 12~15Ncm
- > Fixture level impression

Bite Impression Coping



Type	Hex(Short)	Hex(Long)	Hex(X-Long)	
Diameter	Ø4.5	Ø4.5	Ø4.5	
Length	2	4	6	
Cuff	4.0	2SBIC45S	2SBIC45L	2SBIC45X

- > 포장단위 : 1 Bite Impression Coping (Inbuilt Guide Pin)
- > Bite tray 사용
- > Bite와 Impression 동시 채득 가능
- > Hex Driver를 사용하여 체결
- > 권장 체결 토크 : 12~15Ncm
- > Fixture level impression

Pick-up Impression Coping

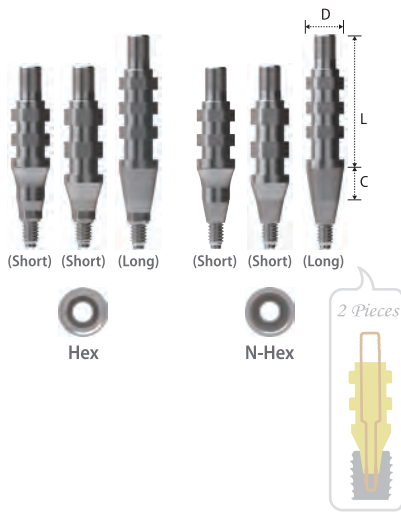

Type	Hex			N-Hex		
Diameter / Length/Cuff	Ø4.5	Ø5.5	Ø6.5	Ø4.5	Ø5.5	Ø6.5
14 (Short) / 4	2SIH454S	2SIH554S	2SIH654S	2SIN454S	2SIN554S	2SIN654S
14 (Short) / 2	2SIH45S	2SIH55S	2SIH65S	2SIN45S	2SIN55S	2SIN65S
16 (Long) / 4	2SIH45L	2SIH55L	2SIH65L	2SIN45L	2SIN55L	2SIN65L

- > 포장단위 : 1 Pick-up Impression Coping + 1 Guide Pin(2SISR001SS / 2SISR001SL)
- > Open tray 사용(Custom tray)
- > Hex Driver를 사용하여 체결
- > 권장 체결 토크 : 12~15Ncm
- > Fixture level impression

Transfer Post

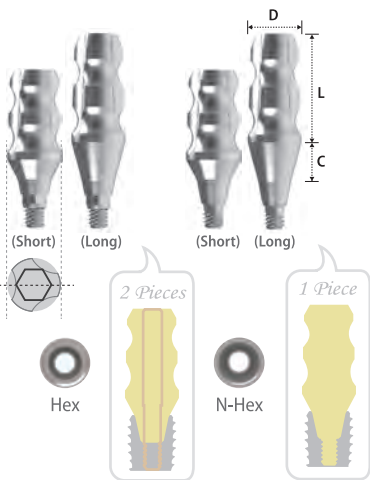

Type	Hex			N-Hex		
Diameter / Length/Cuff	Ø4.5	Ø5.5	Ø6.5	Ø4.5	Ø5.5	Ø6.5
9 (Short) / 2	2STH45S	2STH55S	2STH65S	2STN45S	2STN55S	2STN65S
11 (Long) / 4	2STH45L	2STH55L	2STH65L	2STN45L	2STN55L	2STN65L

- > 포장단위 : Hex- 1 Transfer Post + 1 Guide Pin(2STH001SS / 2STH001SL)
- N-Hex- 1 Transfer Post(Solid type)
- > Closed tray 사용
- > Hex Driver를 사용하여 체결
- > 권장 체결 토크 : 12~15Ncm
- > Fixture level impression

Digital Analog



Diameter / Height	Ø3.9
12	2SDR001

- > 포장단위 : 1 Digital Analog
- > 작업모형 상에 Fixture 형상 구현
- > 3D printing(RP) 및 석고모형에 사용

Replica



Diameter	Ø4
Height	12
2SRHRR001	

- > 포장단위 : 1 Replica
- > Fixture analog로 작업모형 상에 Fixture 형상 구현

SFIT Ti-Base Setting Screw



Diameter	Ø1.95
Height	8.9
2SSFSS100	

- > 포장단위 : 5 SFIT Ti-Base Setting Screws
- > SFIT Ti-Base 및 보철물 Adaptation 시 사용되는 기공용 Screw
- > Hex Driver를 사용하여 체결
- > 권장 체결 토크 : Finger force

• 보철물 시적 시 스프링부가 Spread 되지않는 범위내에서 Fixture와 결합되어 보철물 착탈 용이



Torx S Driver(Machine)

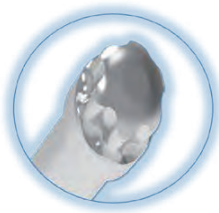
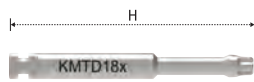

Type	Machine
<i>Stargrip Height</i>	Stargrip 1.8
22	KMTD18S
28	KMTD18L

- > 포장단위 : 1 Torx S Driver(Machine)
- > Contra-angle를 사용하여 체결

Torx S Driver(Ratchet)

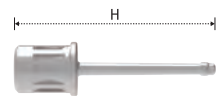

Type	Ratchet
<i>Stargrip Height</i>	Stargrip 1.8
15	KHTD1808
24	KHTD1815
29	KHTD1820

- > 포장단위 : 1 Torx S Driver(Ratchet)
- > Torque Wrench를 사용하여 체결

Torx A Driver(Machine)

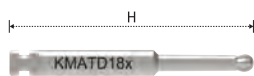

Type	Machine
<i>Stargrip Height</i>	Stargrip 1.8
22	KMATD18S
28	KMATD18L

- > 포장단위 : 1 Torx A Driver(Machine)
- > Contra-angle를 사용하여 체결

Torx A Driver(Ratchet)

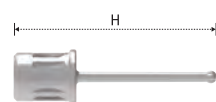

Type	Ratchet
<i>Stargrip Height</i>	Stargrip 1.8
15	KRBUD08
24	KRBUD15
29	KRBUD20

- > 포장단위 : 1 Torx A Driver(Ratchet)
- > Torque Wrench를 사용하여 체결

Hex Driver(Ratchet)

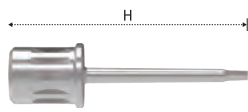

Type	Ratchet
Hex Height	Hex 1.2
17(Short)	KHD1215
23(Long)	KHD1221
29(X-Long)	KHD1227

- > 포장단위 : 1 Hex Driver(Ratchet)
- > Scanbody 및 Pick-up Impression Coping 체결 등에 사용
- > Torque Wrench를 사용하여 체결

SFIT Lift Driver

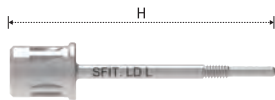

Type	Ratchet
Height	21
	27

- > 포장단위 : 1 SFIT Lift Driver
- > Cold welding(냉간합착)으로 인하여 SFIT Ti-Base가 제거되지 않을 경우 사용



Torque Wrench



Code
KTW001

- > 포장단위 : 1 Torque Wrench
- > 탄성 손잡이를 이용하여 10 / 25 / 30 / 35 Ncm으로 회전력을 제어할 수 있으며, 단단한 일자 손잡이를 잡고 돌리면 최대 120 Ncm



Spreader

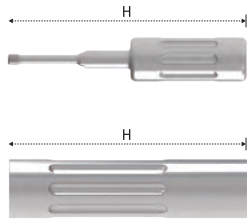

Type	Handle
Height	42

Type	Connector
Height	30

- > Ti-Base와 Crown의 반복된 탈착으로 인하여 Spring의 유지력이 떨어질 경우 Spreader가 SFIT Ti-Base Spring부를 벌려 유지력을 복원
- > 유지력이 떨어진 상태에서 납품 시 셋팅 과정에서 SFIT Ti-Base와 크라운이 분리되어 셋팅 시 어려움 발생
- > 기공소에서 최종 여담 확인 후 초과납품 전 사용권장

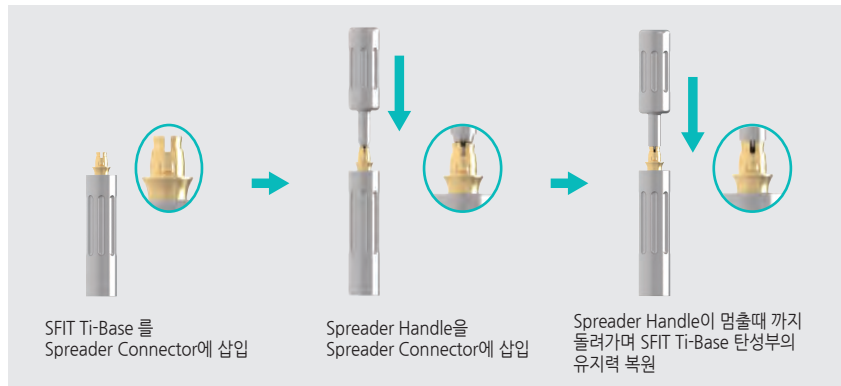

SFIT Crown Gauge

Driver



Holder



Code
SFCG

- > 포장단위 : 3 Holders + 1 Handle
- > 기공과정에 사용되며 SFIT Ti-Base의 Crown 내면 Under cut 확인
- > Color로 SFIT Ti-Base 길이 구분
(Yellow : Length 2.2mm, Purple : Length 3.6mm, Blue : Length 5.0mm)
- > SFIT Ti-Base System의 가장 중요한 부분 중 하나는 Crown 내부의 언더컷(Undercut) 가공임. 크라운 게이지는 크라운 내부의 언더컷을 확인할 수 있는 가장 중요한 기구 중 하나로 홀더와 드라이버로 구성됨
- > 홀더는 Post 길이에 따라 Yellow(Post 2.2mm), Purple(Post 3.6mm), Blue(Post 5mm)로 구성됨
- > 내부 언더컷을 제대로 가공하지 않으면 나사 풀림, 보철물 탈락 등의 문제가 발생할 수 있음

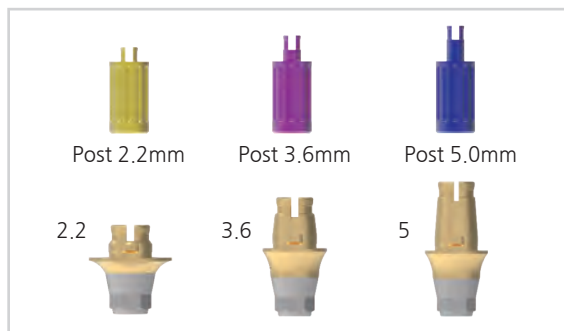

SFIT Crown Gauge 사용 방법

① SFIT Ti-Base Length에 맞는 Holder에 Driver를 시계 방향으로 체결



O 완전히 체결하지 않고 일정 깊이까지만 체결



X 끝까지 체결할 경우 크라운이 결합되지 않음



② 크라운 결합

- 결합 후 살짝 흔들었을 때 크라운이 빠지거나 끝까지 체결되지 않을 경우 내면 밀링이 잘못 된 것으로 판단



③ Driver를 손힘(15N)을 이용하여 시계방향으로 완전히 체결

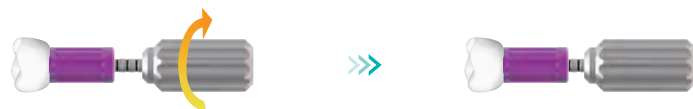

유지력

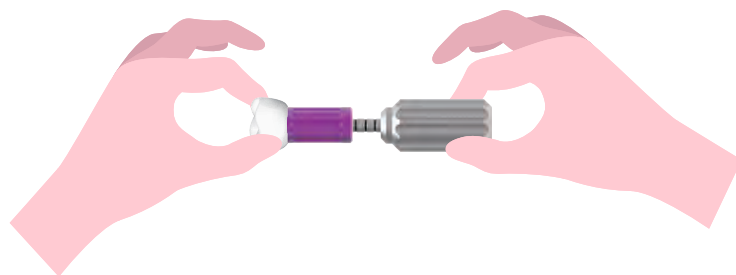

Crown과 Driver를 양손으로 잡고 힘껏 당겼을 시(30~45N)

- ① 크라운이 분리될 경우: 내부 밀링 불량
- ② 크라운이 분리되지 않을 경우: 내부 밀링 양호

Component selection guide for the Sub. Multi SFIT Ti-Base

- Intra-oral scanning
- Model scanning

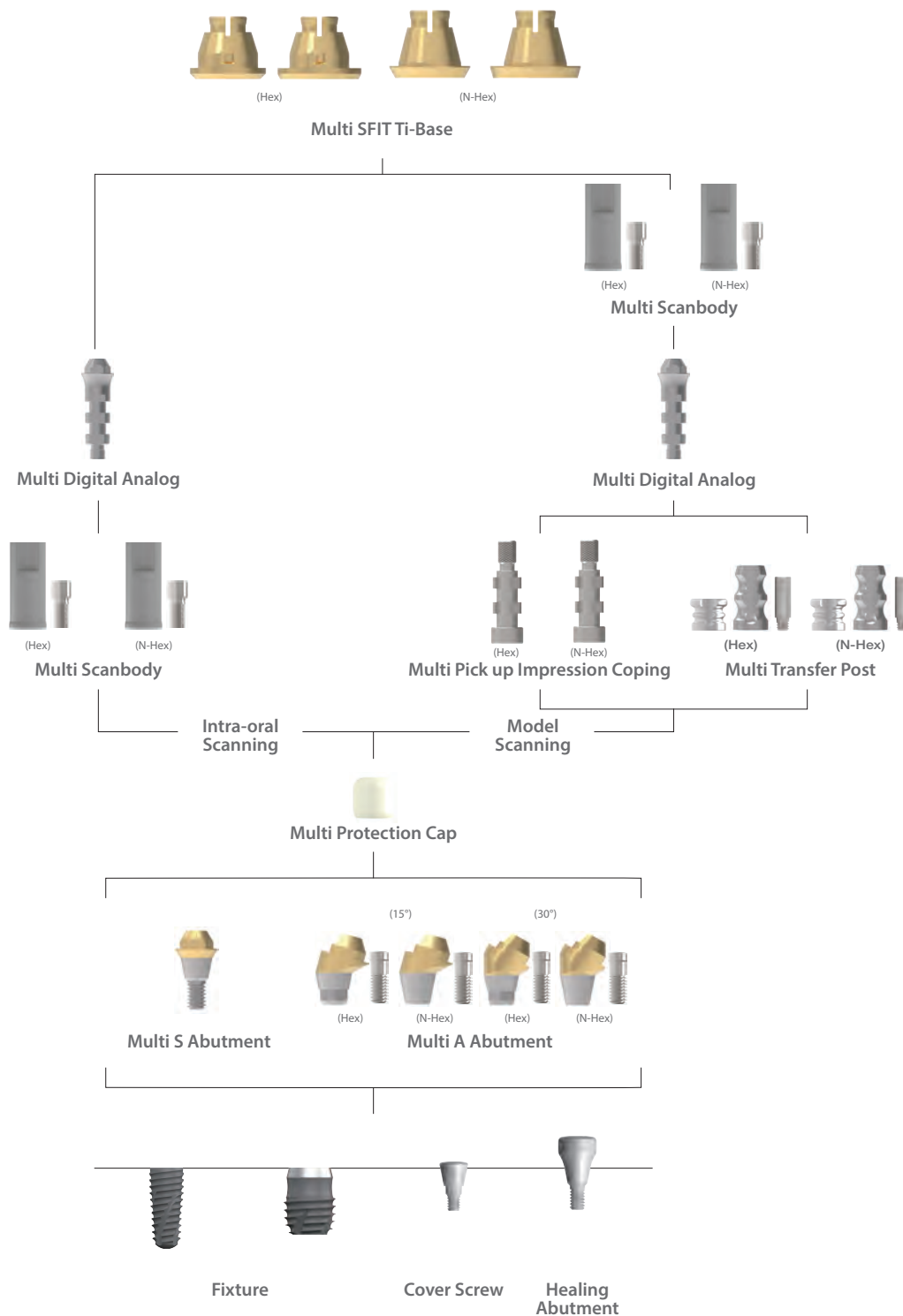

Multi S Abutment

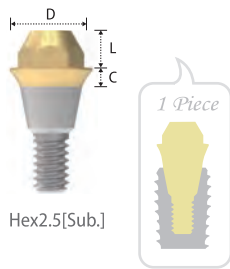

Fixture Connection	Hex2.5[Sub.]	
Platform[Fixture Dia.]	Ø4.5 [Ø3.5 / Ø4.0 / Ø4.5 / Ø5.0 / Ø5.5 / Ø6.0]	
Diameter	Ø4.5	Ø5.5
Length	2	2
Cuff		
1	2SMS451	2SMS551
2	2SMS452	2SMS552
3	2SMS453	2SMS553
4	2SMS454	2SMS554
5	2SMS455	2SMS555

- > 포장단위 : 1 Multi S Abutment
- > SRP 유지형 보철 제작
- > Multi SFIT Ti-Base를 위한 Titanium-Base
- > Screw와 Abutment의 일체형 구조(Solid type)
- > 심미성을 위한 Gold coloring
- > Scanbody 사용 시 Digital work 가능
- > 3shape 및 Exocad용 라이브러리 제공
- > Multi S Holder를 사용하여 구강 내 Delivery
- > Multi S Driver와 Torque Wrench를 사용하여 체결
- > 권장 체결 토크 : 30Ncm
- > Abutment level impression

Multi A Abutment

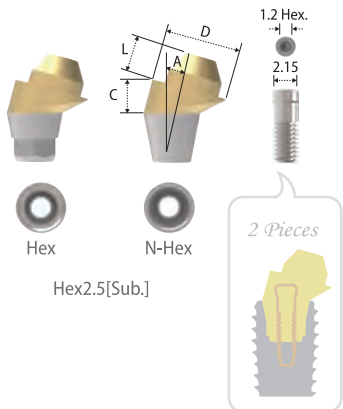

Type	Hex			
Fixture Connection	Hex2.5[Sub.]			
Platform[Fixture Dia.]	Ø4.5[Ø3.5/Ø4.0/Ø4.5/Ø5.0/Ø6.0]		Ø5.5[Ø3.5/Ø4.0/Ø4.5/Ø5.0/Ø6.0]	
Diameter	Ø4.5(15°)	Ø4.5(30°)	Ø5.5(15°)	Ø5.5(30°)
Length	2	2	2	2
Cuff				
2	● 2SMAH45152			
3	★ 2SMAH45153	● 2SMAH45303	★ 2SMAH55153	★ 2SMAH55303
4	★ 2SMAH45154	★ 2SMAH45304	★ 2SMAH55154	★ 2SMAH55304
5			★ 2SMAH55155	★ 2SMAH55305

Type	N-Hex			
Fixture Connection	Hex2.5[Sub.]			
Platform[Fixture Dia.]	Ø4.5[Ø3.5/Ø4.0/Ø4.5/Ø5.0/Ø6.0]		Ø5.5[Ø3.5/Ø4.0/Ø4.5/Ø5.0/Ø6.0]	
Diameter	Ø4.5(15°)	Ø4.5(30°)	Ø5.5(15°)	Ø5.5(30°)
Length	2	2	2	2
Cuff				
2	● 2SMAN45152			
3	★ 2SMAN45153	● 2SMAN45303	★ 2SMAN55153	★ 2SMAN55303
4	★ 2SMAN45154	★ 2SMAN45304	★ 2SMAN55154	★ 2SMAN55304
5			★ 2SMAN55155	★ 2SMAN55305

- > 포장단위 : 1 Multi A Abutment + Abutment Screw (2SSHR300: ★, 2SSHR400: ●)
- > SRP 유지형 보철 제작
- > Multi SFIT Ti-Base를 위한 Titanium-Base
- > Fixture path 보상(2개의 fixture 기준 최대 90°)
- > 심미성을 위한 Gold coloring
- > Scanbody 사용 시 Digital work 가능
- > 3shape 및 Exocad용 라이브러리 제공
- > Multi A Holder를 사용하여 구강 내 Delivery
- > Hex Driver와 Torque Wrench를 사용하여 체결
- > 권장 체결 토크 : 30Ncm
- > Abutment level impression

Abutment Screw



<i>Height</i> <i>Diameter</i>	7.5	6.5
2.15	★2SSHR300	●2SSHR400

- > 포장단위 : 1 Abutment Screw
- > Multi A Abutment 체결 시 사용
- > Hex Driver와 Torque Wrench를 사용하여 체결

Multi Protection Cap

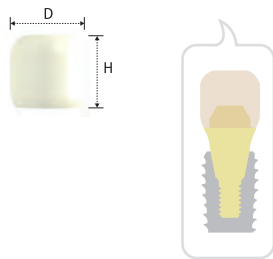

<i>Multi S&A</i> <i>Abutment Diameter</i>	Ø4.5	Ø5.5
<i>Diameter</i> <i>Height</i>	Ø5.2	Ø6.2
5	2SMPC45	2SMPC55

- > 포장단위 : 1 Multi Protection Cap
- > 치유기간 중 구강 내 Abutment를 보호하고 환자의 이물감을 최소화
- > Abutment의 보철 마진을 형성하기 위한 Gingival retraction에 사용
- > 임시 보철의 하부구조로 사용 가능
- > Hex Driver로 체결
- > 권장 체결 토크: 5~10Ncm

Multi Scanbody

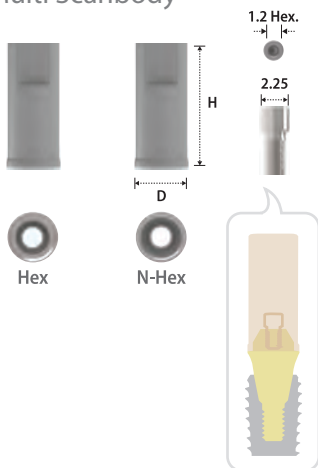

<i>Type</i>	Hex	N-Hex
<i>Multi S&A</i> <i>Abutment Diameter</i>	Ø4.5 & Ø5.5	Ø4.5 & Ø5.5
<i>Diameter</i> <i>Height</i>	Ø4.5	Ø4.5
9	2SMB001H	2SMB001N

- > 포장단위 : 1 Scanbody + 1 Multi Cylinder Screw(2SMCS100)
- > 내구성이 뛰어나고 정밀한 공차로 정확한 Digital impression(Scanning)
- > 특수 코팅적용한 100% 티타늄 합금
- > Scan spray 및 Sand Blasting등의 과정이 불필요
- > Hex Driver를 사용하여 체결
- > 권장 체결 토크 : 12~15Ncm
- > Abutment level impression

Multi Pick-up Impression Coping

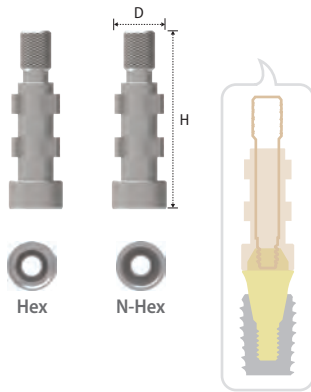

Type	Hex		N-Hex	
Multi S&A Abutment Diameter	Ø4.5	Ø5.5	Ø4.5	Ø5.5
Diameter / Length	Ø4.65	Ø5.65	Ø4.65	Ø5.65
16	2SMIH45	2SMIH55	2SMIN45	2SMIN55

- > 포장단위 : 1 Multi Pick-up Impression Coping + 1 Guide Pin(2SMGP012)
- > Open tray 사용(Custom tray)
- > Hex Driver를 사용하여 체결
- > 권장 체결 토크 : 12~15Ncm
- > Abutment level impression

Multi Transfer Post

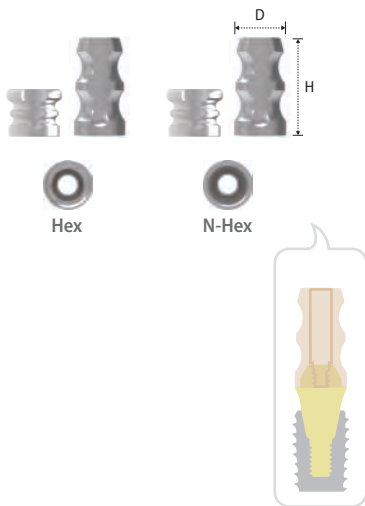

Type	Hex		N-Hex	
Multi S&A Abutment Diameter	Ø4.5	Ø5.5	Ø4.5	Ø5.5
Diameter / Height	Ø4.5	Ø5.5	Ø4.5	Ø5.5
5	2SMTH455	2SMTH555	2SMTN455	2SMTN555
8.5	2SMTH45	2SMTH55	2SMTN45	2SMTN55

- > 포장단위 : 1 Multi Transfer Post + 1 Guide Pin(2SMTHS100)
- > Closed tray 사용
- > Hex Driver를 사용하여 체결
- > 권장 체결 토크 : 12~15Ncm
- > Abutment level impression

Multi Digital Analog



Multi S&A Abutment Diameter	Ø4.5	Ø5.5
Diameter / Length	Ø4.5	Ø5.5
2	2SMLA45	2SMLA55

- > 포장단위 : 1 Digital Analog
- > 작업모형 상에 Abutment 형상 구현
- > 3D printing(RP) 및 석고모형에 사용
- > Abutment 직경에 따라 사용

Multi Polishing Protector

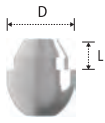

Type	Hex
Multi S&A Abutment Diameter	Ø4.5
Diameter / Length	Ø4.5
2	2SMPP45

- > 포장단위 : 1 Multi Polishing Protector
- > 가공 과정에서 Polishing 작업 시 Margin 보호

Multi S Driver(Machine)

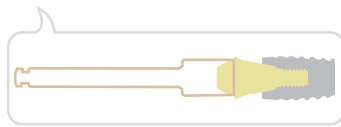
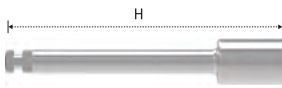

Type	Machine
Height	27.5
	KMMSD21L

- > 포장단위 : 1 Multi S Machine Driver
- > Contra-angle를 사용하여 Multi S Abutment 체결

Multi S Driver(Ratchet)

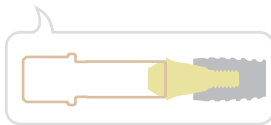
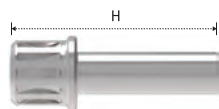

Type	Ratchet
Height	22
	KMMSD15L

- > 포장단위 : 1 Multi S Ratchet Driver
- > Torque Wrench를 사용하여 Multi S Abutment 체결

Multi Holder

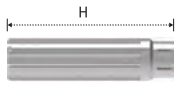

S Holder



Type	Hand
Height 20	KMHS01

- > 포장단위 : 1 Multi S Holder
- > 안정적으로 Multi S Abutment를 위치시키기 위하여 사용

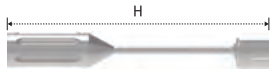

A Holder

Type	Hand
Height 32	KMHA01

- > 포장단위 : 1 Multi A Holder
- > 안정적으로 Multi A Abutment를 위치시키기 위하여 사용



① Multi A Abutment에 Abutment Screw를 넣고 Multi A Holder와 연결한 뒤 Abutment와 Holder의 방향을 맞춤

② Multi A Holder의 손잡이를 잡고 구강 내 위치에 맞춰서 구부림

③ Fixture에 연결

④ Hex Driver와 Torque Wrench를 사용하여 Multi A Abutment를 조임

Multi SFIT Ti Base

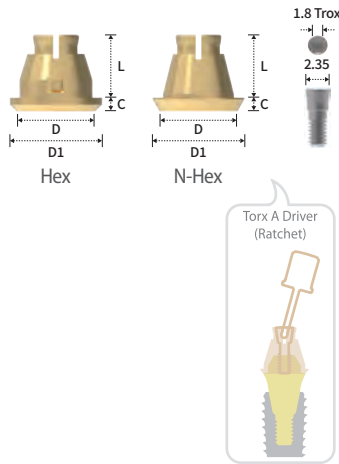

Type	Hex	
Multi S&A Abutment Diameter	Ø4.5	Ø5.5
Diameter(D)	Ø4.5	Ø5.5
Diameter(D1)	Ø5.3	Ø5.9
Length	3.6	3.6
Cuff	0.8	0.8
	2SMSFT45HA	2SMSFT55HA

Type	N-Hex	
Multi S&A Abutment Diameter	Ø4.5	Ø5.5
Diameter(D)	Ø4.5	Ø5.5
Diameter(D1)	Ø5.3	Ø5.9
Length	3.6	3.6
Cuff	0.8	0.8
	2SMSFT45NA	2SMSFT55NA

- > 포장단위 : 1 Multi SFIT Ti-Base
- > Spread Fit™ 유지형 Cementless보철 제작으로 유지보수가 매우 용이
- > Angulated screw channel 형성 가능(최대 25°)
- > Multi A Abutment 사용 시 최대 110°까지 Fixture 식립 Path 보상
- > 심미성을 위한 Gold coloring
- > 3shape 및 Exocad용 라이브러리 제공(5µm 단위로 세분화)
- > Torx Driver와 Torque Wrench를 사용하여 체결
(Straight screw channel : Torx S Driver / Angulated screw channel : Torx A Driver)
- > 권장 체결 토크 : 25Ncm

Multi SFIT Ti Base Screw



Diameter	Ø2.3
Height	5.5
	2SMCS100AF

- > 포장단위 : 1 Multi SFIT Ti-Base Screw
- > Angulated screw channel 형성 가능(최대 25°)
- > Torx S Driver 또는 Torx A Driver 와 Torque Wrench를 사용하여 체결

Multi SFIT Setting Screw

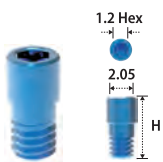

Diameter	Ø2.0
Height	4.3
	2SMCSS100

- > 포장단위 : 5 Multi SFIT Ti-Base Setting Screws
- > Multi SFIT Ti-Base 및 보철물 Adaptation 시 사용되는 기공용 Screw
- > Hex Driver를 사용하여 체결
- > 권장 체결 토크: Finger force

Multi SFIT Crown Gauge



Code
SFMCG

- > 포장단위 : 1 Holder + 1 Handle
- > 기공과정에 사용되며 Multi SFIT Ti-Base의 Crown 내면 Under cut 확인

Spreader

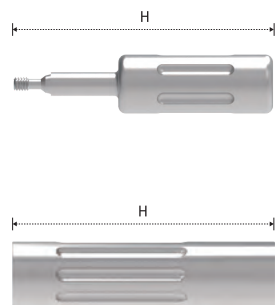

Type	Handle
Height	33.5
	2SMSFSP01H

Type	Connector
Height	30
	2SSFSP01C

- > Ti-Base와 Crown의 반복된 탈착으로 인하여 Spring의 유지력이 떨어질 경우 Spreader가 SFIT Ti-Base Spring부를 벌려 유지력을 복원
- > 유지력이 떨어진 상태에서 납품 시 셋팅 과정에서 SFIT Ti-Base와 크라운이 분리되어 셋팅 시 어려움 발생
- > 기공소에서 최종 어답 확인 후 치과납품 전 사용권장

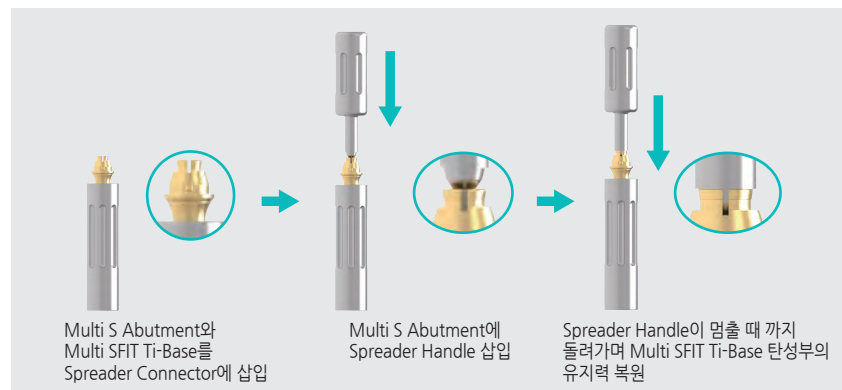

Component selection guide for the Sub-N. SFIT Ti-Base

- Intra-oral scanning
- Model scanning

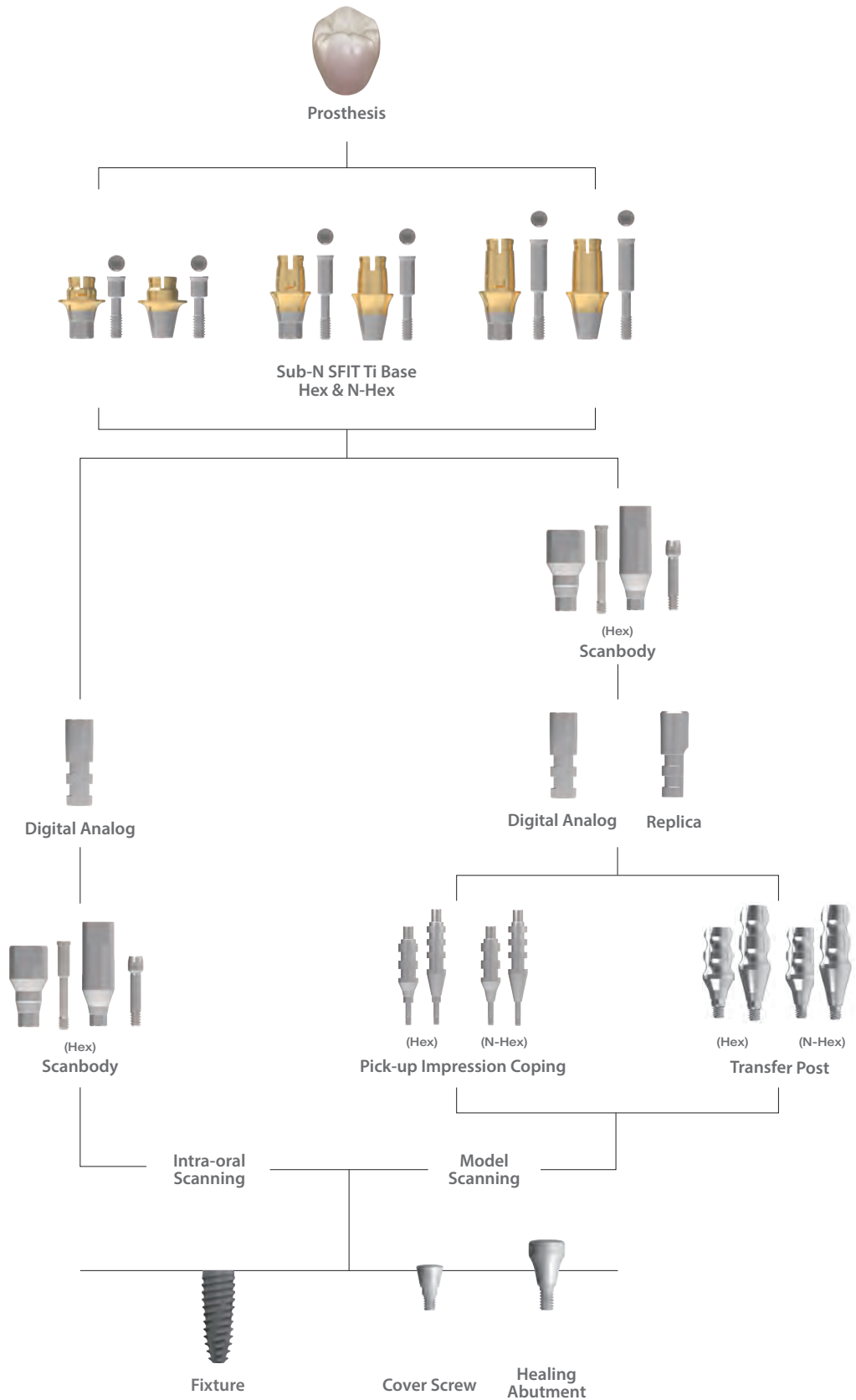

Sub-N. SFIT Ti-Base

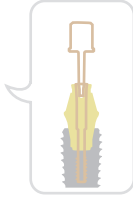
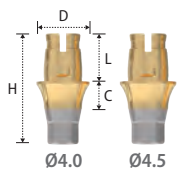

Type	Hex					
Length	2.2		3.6		5.0	
Cuff / Diameter	Ø4.0	Ø4.5	Ø4.0	Ø4.5	Ø4.0	Ø4.5
0.5	SSFH38020NA	SSFH45020NA	-	-	-	-
1	SSFH38120NA	SSFH45120NA	SSFH38135NA	SSFH45135NA	SSFH38150NA	SSFH45150NA
2	SSFH38220NA	SSFH45220NA	SSFH38235NA	SSFH45235NA	SSFH38250NA	SSFH45250NA
3	SSFH38320NA	SSFH45320NA	SSFH38335NA	SSFH45335NA	SSFH38350NA	SSFH45350NA
4	-	-	SSFH38435NA	SSFH45435NA	SSFH38450NA	SSFH45450NA

- > 포장단위 : 1 Sub-N. SFIT Ti-Base + 1 SFIT Ti-Base Screw
- > Spread Fit™ 유지형 Cementless보철 제작으로 유지보수가 매우 용이
- > Angulated screw channel 형성 가능(최대 25°)
- > 극도로 짧은 치관 및 낮은 교합고경에서도 사용 가능
- > 심미성을 위한 Gold coloring 및 회전방지 돌기 부여
- > 3shape 및 Exocad용 라이브러리 제공(5 μ m 단위로 세분화)
- > Torx Driver와 Torque Wrench를 사용하여 체결
(Straight screw channel: Torx S Driver / Angulated screw channel: Torx A Driver)
- > 권장 체결 토크 : 20~25Ncm
- > Fixture level impression

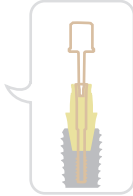
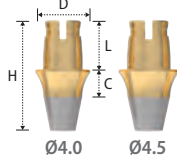

Type	N-Hex					
Length	2.2		3.6		5.0	
Cuff / Diameter	Ø4.0	Ø4.5	Ø4.0	Ø4.5	Ø4.0	Ø4.5
0.5	SSFN38020NA	SSFN45020NA	-	-	-	-
1	SSFN38120NA	SSFN45120NA	SSFN38135NA	SSFN45135NA	SSFN38150NA	SSFN45150NA
2	SSFN38220NA	SSFN45220NA	SSFN38235NA	SSFN45235NA	SSFN38250NA	SSFN45250NA
3	SSFN38320NA	SSFN45320NA	SSFN38335NA	SSFN45335NA	SSFN38350NA	SSFN45350NA
4	-	-	SSFN38435NA	SSFN45435NA	SSFN38450NA	SSFN45450NA

- > Healing Abutment의 Size는 사용 될 Sub-N. SFIT Ti-Base의 직경보다 한 단계 큰 Size 권장
- > 잇몸 압박으로 인한 Ti-Base seating의 어려움 발생을 방지 및 올바른 Emergence profile 형성에 유리
ex) Ø4.5 SFIT Ti-Base 사용 시 Ø5.5 Healing Abutment 사용

SFIT Ti-Base Screw

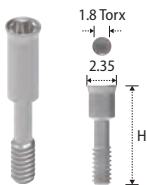

Length / Cuff	2.2		3.6		5.0	
	Code	H	Code	H	Code	H
0.5	SSFS05A20N	9.7	-	-	-	-
1	SSFS15A20N	10.2	SSFS10A35N	11.6	SSFS10A50N	13
2	SSFS25A20N	11.2	SSFS20A35N	12.6	SSFS20A50N	14
3	SSFS35A20N	12.2	SSFS30A53N	13.6	SSFS30A50N	15
4	SSFS40A20N	13.2	SSFS40A35N	14.6	SSFS40A50N	16

- > 포장단위 : 1 SFIT Ti-Base Screw
- > Angulated screw channel 형성 가능(최대 25°)
- > Torx S Driver 또는 Torx A Driver 와 Torque Wrench를 사용하여 체결

Scanbody

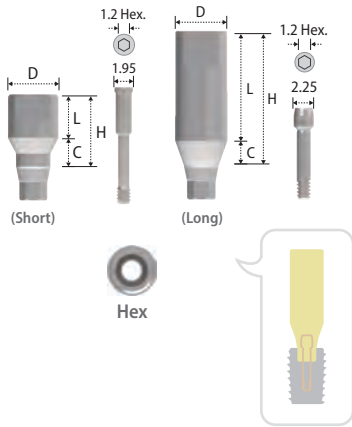

Type	Hex(Short)	Hex(Long)
Diameter	Ø4.3	Ø4.3
Height	6	11
Length / Cuff	4	9
	SSB4325N	SSB4329N

- > 포장단위 : 1 Scanbody + 1 Abutment Screw
- > 모델스캐너 및 구강스캐너 모두 사용 가능
- > 특수 코팅적용한 100% 티타늄 합금
- > Scan spray 및 Sand Blasting등의 과정이 불필요
- > Hex Driver와 Torque Wrench로 체결
- > 권장 체결 토크 : 12~15Ncm

Pick-up Impression Coping

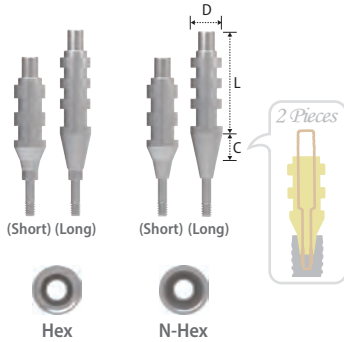

Type	Hex	N-Hex
Diameter	Ø4.5	Ø4.5
Length / Cuff		
14 (Short) / 2	SIH45SN	SIN45SN
16 (Long) / 4	SIH45LN	SIN45LN

- > 포장단위 : 1 Pick-up Impression Coping + 1 Guide Pin
- > Open tray impression
- > Guide Pin (SIS001SN/SIS001LN)으로 체결
- > Hex Driver와 Torque Wrench로 체결
- > 권장 체결 토크 : 12~15Ncm

Transfer Post

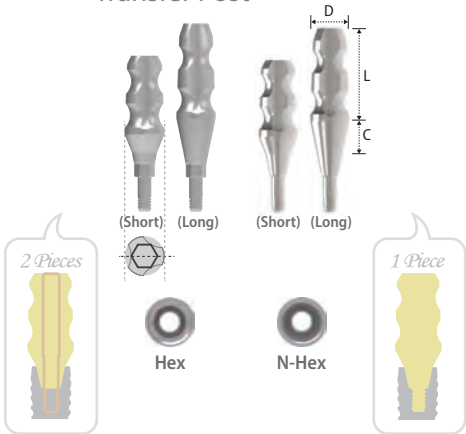

Type	Hex	N-Hex
Diameter	Ø4.5	Ø4.5
Length / Cuff		
9 (Short) / 2	STH45SN	STN45SN
11 (Long) / 4	STH45LN	STN45LN

- > 포장단위 : 1 Transfer Post + 1 Guide Pin / N-Hex - 1 Transfer Post (Solid Type)
- > Closed tray impression
- > Guide Pin (STS001SN/STS001LN)으로 체결
- > Hex Driver와 Torque Wrench로 체결
- > 권장 체결 토크 : 12~15 Ncm

Digital Analog



Diameter	Ø3.9
Height	12
	SDR001N

- > 포장단위 : 1 Digital Analog
- > 작업모형 상에 Fixture 형상 구현
- > 3D printing(RP) 및 석고모형에 사용

Replica



<i>Diameter</i>	Ø4
<i>Height</i>	2SRHRR001

- > 포장단위 : 1 Replica
- > Fixture analog로 작업모형 상에 Fixture 형상 구현

SFIT Ti-Base Setting Screw



<i>Diameter</i>	Ø1.95
<i>Height</i>	SSFSS100N

- > 포장단위 : 5 SFIT Ti-Base Setting Screws
- > Sub-N. SFIT Ti-Base 및 보철물 Adaptation 시 사용되는 기공용 Screw
- > Hex Driver를 사용하여 체결
- > 권장 체결 토크 : Finger force

• 보철물 시적 시 스프링부가 Spread 되지않는 범위내에서 Fixture와 결합되어 보철물 착탈 용이



Sub-N. SFIT Lift Driver

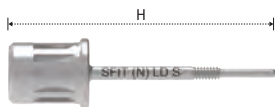

<i>Type</i>	Ratchet
<i>Diameter</i>	Ø7.9
<i>Height</i>	
30	KHSPLD01SN
36	KHSPLD01SL

- > 포장단위 : 1 Sub-N. SFIT Lift Driver
- > Cold welding(냉간합착)으로 인하여 Sub-N. SFIT Ti-Base가 제거되지 않을 경우 사용



Spreader

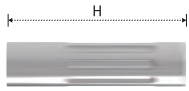
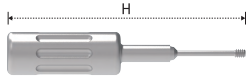

Type	Handle
Diameter	Ø7.5
Height	42
	SSFSP01HN

Type	Connector
Diameter	Ø7.5
Height	30
	SSFSP01CN

- > Sub-N. SFIT Ti-Base와 Crown의 반복된 탈착으로 인하여 Spring의 유지력이 떨어질 경우 Spreader가 Sub-N. SFIT Ti-Base Spring부를 벌려 유지력을 복원
- > 유지력이 떨어진 상태에서 납땜 시 셋팅 과정에서 Sub-N. SFIT Ti-Base와 크라운이 분리되어 셋팅 시 어려움 발생
- > 기공소에서 최종 어답 확인 후 치과납땜 전 사용권장

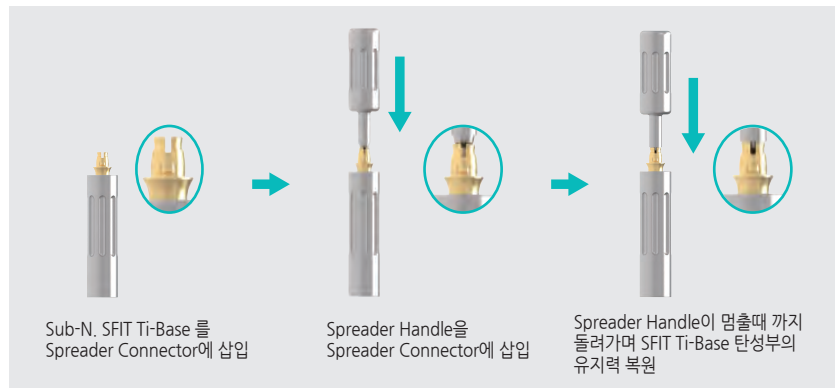

SFIT Crown Gauge

Driver



Holder



Code
SFCG

- > 포장단위 : 3 Holders + 1 Handle
- > 기공과정에 사용되며 Sub-N. SFIT Ti-Base의 Crown 내면 Under cut 확인
- > Color로 SFIT Ti-Base 길이 구분
(Yellow : Length 2.2mm, Purple : Length 3.6mm, Blue : Length 5.0mm)
- > Sub-N. SFIT Ti-Base System의 가장 중요한 부분 중 하나는 Crown 내부의 언더컷(Undercut) 가공임. 크라운 게이지는 크라운 내부의 언더컷을 확인할 수 있는 가장 중요한 기구 중 하나로 홀더와 드라이버로 구성됨
- > 홀더는 Post 길이에 따라 Yellow(Post 2.2mm), Purple(Post 3.6mm), Blue(Post 5mm)로 구성됨
- > 내부 언더컷을 제대로 가공하지 않으면 나사 풀림, 보철물 탈락 등의 문제가 발생할 수 있음

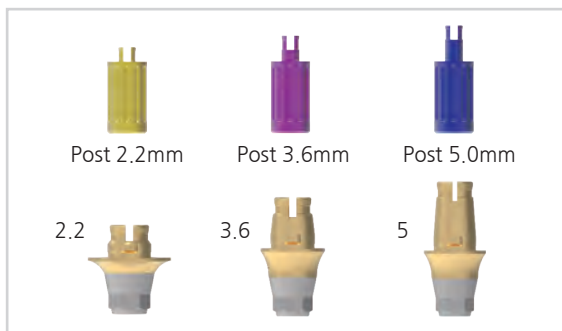

SFIT Crown Gauge 사용 방법

- ① Sub-N. SFIT Ti-Base Length에 맞는 Holder에 Driver를 시계 방향으로 체결

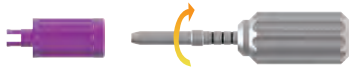

O 완전히 체결하지 않고 일정 깊이까지만 체결



X 끝까지 체결할 경우 크라운이 결합되지 않음



- ② 크라운 결합

- 결합 후 살짝 흔들었을 때 크라운이 빠지거나 끝까지 체결되지 않을 경우 내면 밀링이 잘못 된 것으로 판단



- ③ Driver를 손힘(15N)을 이용하여 시계방향으로 완전히 체결



유지력

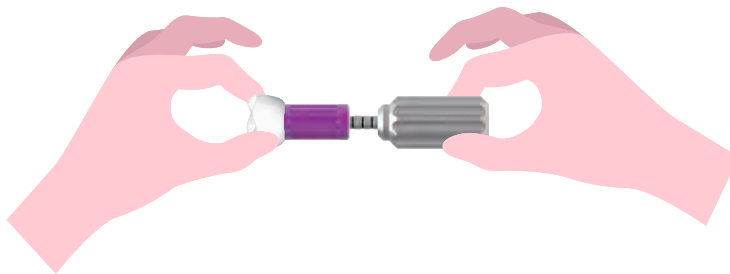

Crown과 Driver를 양손으로 잡고 힘껏 당겼을 시(30~45N)

- ① 크라운이 분리될 경우: 내부 밀링 불량
② 크라운이 분리되지 않을 경우: 내부 밀링 양호

Component selection guide for the Sub-N. Multi SFIT Ti-Base

- Intra-oral scanning
- Model scanning

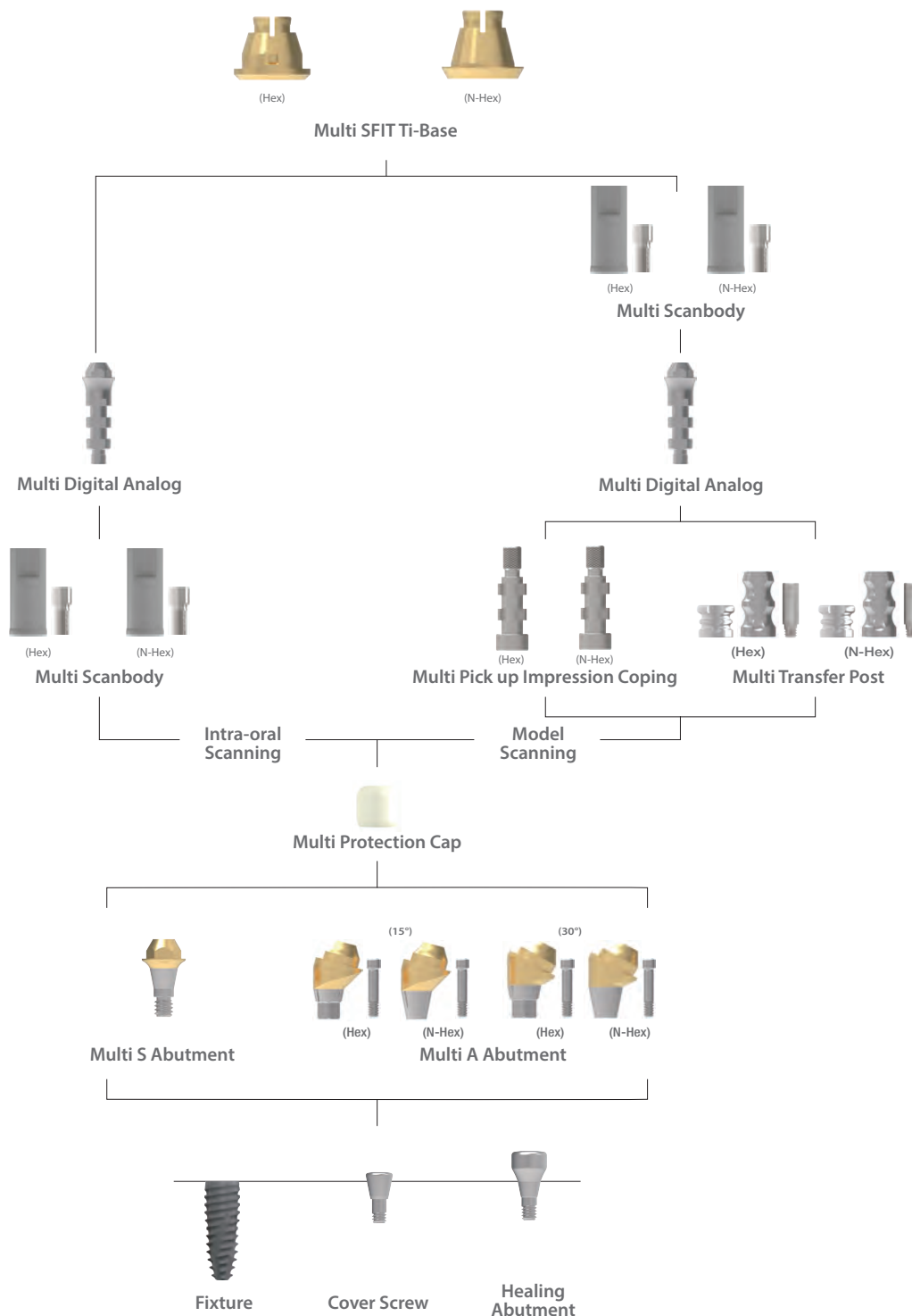

Multi S Abutment

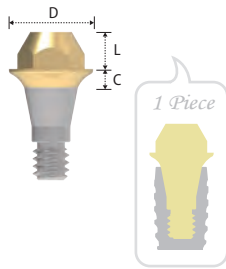

Diameter	Ø4.5
Cuff / Length	2
1	SMS451N
2	SMS452N
3	SMS453N
4	SMS454N

- > 포장단위 : 1 Multi S Abutment
- > SRP 유지형 보철 제작
- > Multi SFIT Ti-Base를 위한 Titanium-Base
- > Screw와 Abutment의 일체형 구조(Solid type)
- > 심미성을 위한 Gold coloring
- > Scanbody 사용 시 Digital work 가능
- > 3shape 및 Exocad용 라이브러리 제공
- > Multi S Holder를 사용하여 구강 내 Delivery
- > Multi S Driver와 Torque Wrench를 사용하여 체결
- > 권장 체결 토크 : 20~25Ncm
- > Abutment level impression

Multi A Abutment

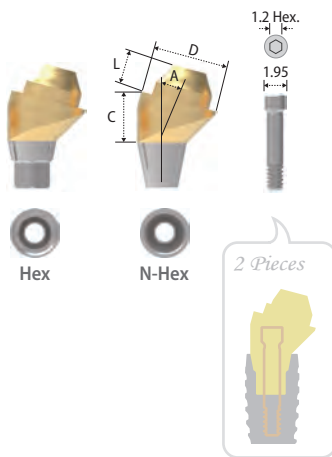

Type	Hex	
Diameter(Angle)	Ø4.5(15°)	Ø4.5(30°)
Cuff / Length	2	2
2	★ SMAH45152N	
3	● SMAH45153N	★ SMAH45303N
4	● SMAH45154N	● SMAH45304N

Type	N-Hex	
Diameter(Angle)	Ø4.5(15°)	Ø4.5(30°)
Cuff / Length	2	2
2	★ SMAN45152N	
3	● SMAN45153N	★ SMAN45303N
4	● SMAN45154N	● SMAN45304N

- > 포장단위 : 1 Multi A Abutment + Abutment Screw (SSHR200N: ★, SSHR300N: ●)
- > SRP 유지형 보철 제작
- > Multi SFIT Ti-Base를 위한 Titanium-Base
- > Fixture path 보상(2개의 fixture 기준 최대 90°)
- > 심미성을 위한 Gold coloring
- > Scanbody 사용 시 Digital work 가능
- > 3shape 및 Exocad용 라이브러리 제공
- > Multi A Holder를 사용하여 구강 내 Delivery
- > Hex Driver와 Torque Wrench를 사용하여 체결
- > 권장 체결 토크 : 20~25Ncm
- > Abutment level impression

Abutment Screw

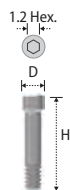

Height	8.7	9.3
Diameter	Ø1.95 ★ SSHR200N	● SSHR300N

- > 포장단위 : 1 Abutment Screw
- > Multi A Abutment 체결 시 사용
- > Hex Driver와 Torque Wrench를 사용하여 체결

Multi Protection Cap

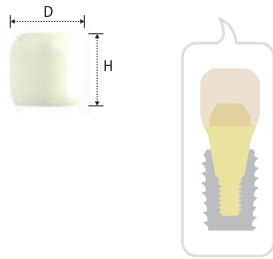

Multi S&A Abutment Diameter	Ø4.5	Ø5.5
Diameter Height	Ø5.2	Ø6.2
5	2SMPC45	2SMPC55

- > 포장단위 : 1 Multi Protection Cap
- > 치유기간 중 구강 내 Abutment를 보호하고 환자의 이물감을 최소화
- > Abutment의 보철 마진을 형성하기 위한 Gingival retraction에 사용
- > 임시 보철의 하부구조로 사용 가능
- > Hex Driver로 체결
- > 권장 체결 토크: 5~10Ncm

Multi Scanbody

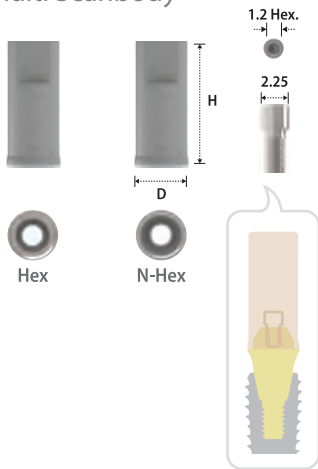

Type	Hex	N-Hex
Multi S&A Abutment Diameter	Ø4.5 & Ø5.5	Ø4.5 & Ø5.5
Diameter Height	Ø4.5	Ø4.5
9	2SMB001H	2SMB001N

- > 포장단위 : 1 Scanbody + 1 Multi Cylinder Screw(2SMCS100)
- > 내구성이 뛰어나고 정밀한 공차로 정확한 Digital impression(Scanning)
- > 특수 코팅적용한 100% 티타늄 합금
- > Scan spray 및 Sand Blasting등의 과정이 불필요
- > Hex Driver를 사용하여 체결
- > 권장 체결 토크 : 12~15Ncm
- > Abutment level impression

Multi Pick-up Impression Coping

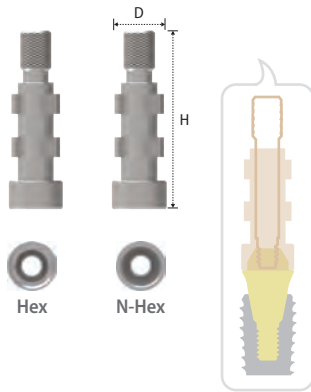

Type	Hex		N-Hex	
Multi S&A Abutment Diameter	Ø4.5	Ø5.5	Ø4.5	Ø5.5
Diameter / Length	Ø4.65	Ø5.65	Ø4.65	Ø5.65
16	2SMIH45	2SMIH55	2SMIN45	2SMIN55

- > 포장단위 : 1 Multi Pick-up Impression Coping + 1 Guide Pin(2SMGP012)
- > Open tray 사용(Custom tray)
- > Hex Driver를 사용하여 체결
- > 권장 체결 토크 : 12~15Ncm
- > Abutment level impression

Multi Transfer Post

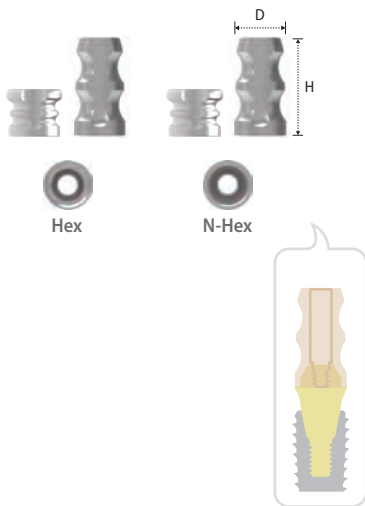

Type	Hex		N-Hex	
Multi S&A Abutment Diameter	Ø4.5	Ø5.5	Ø4.5	Ø5.5
Diameter / Height	Ø4.5	Ø5.5	Ø4.5	Ø5.5
5	2SMTH455	2SMTH555	2SMTN455	2SMTN555
8.5	2SMTH45	2SMTH55	2SMTN45	2SMTN55

- > 포장단위 : 1 Multi Transfer Post + 1 Guide Pin(2SMTHS100)
- > Closed tray 사용
- > Hex Driver를 사용하여 체결
- > 권장 체결 토크 : 12~15Ncm
- > Abutment level impression

Multi Digital Analog



Multi S&A Abutment Diameter	Ø4.5	Ø5.5
Diameter / Length	Ø4.5	Ø5.5
2	2SMLA45	2SMLA55

- > 포장단위 : 1 Digital Analog
- > 작업모형 상에 Abutment 형상 구현
- > 3D printing(RP) 및 석고모형에 사용
- > Abutment 직경에 따라 사용

Multi Polishing Protector

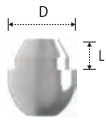

Type	Hex
Multi S&A Abutment Diameter	Ø4.5
Diameter	Ø4.5
Length	2
2SMPP45	

- > 포장단위 : 1 Multi Polishing Protector
- > 가공 과정에서 Polishing 작업 시 Margin 보호

Multi S Driver(Machine)

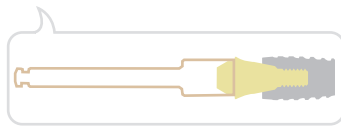
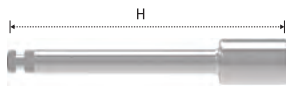

Type	Machine
Height	27.5
KMMSD21L	

- > 포장단위 : 1 Multi S Machine Driver
- > Contra-angle를 사용하여 Multi S Abutment 체결

Multi S Driver(Ratchet)

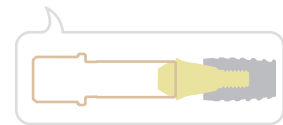
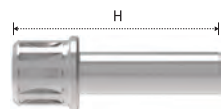

Type	Ratchet
Height	22
KMMSD15L	

- > 포장단위 : 1 Multi S Ratchet Driver
- > Torque Wrench를 사용하여 Multi S Abutment 체결

Multi Holder

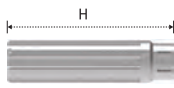

S Holder



Type	Hand
Height 20	KMHS01

- > 포장단위 : 1 Multi S Holder
- > 안정적으로 Multi S Abutment를 위치시키기 위하여 사용

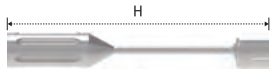

A Holder

Type	Hand
Height 32	KMHA01

- > 포장단위 : 1 Multi A Holder
- > 안정적으로 Multi A Abutment를 위치시키기 위하여 사용



① Multi A Abutment에 Abutment Screw를 넣고 Multi A Holder와 연결한 뒤 Abutment와 Holder의 방향을 맞춤

② Multi A Holder의 손잡이를 잡고 구강 내 위치에 맞춰서 구부림

③ Fixture에 연결

④ Hex Driver와 Torque Wrench를 사용하여 Multi A Abutment를 조임

Multi SFIT Ti Base

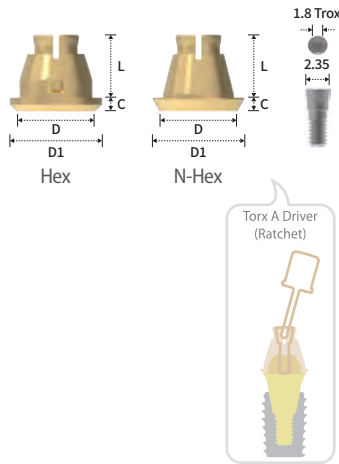

Type	Hex
Multi S&A Abutment Diameter	Ø4.5
Diameter(D)	Ø4.5
Diameter(D1)	Ø5.3
Length	3.6
Cuff	0.8
2SMSFT45HA	

Type	N-Hex
Multi S&A Abutment Diameter	Ø4.5
Diameter(D)	Ø4.5
Diameter(D1)	Ø5.3
Length	3.6
Cuff	0.8
2SMSFT45NA	

- > 포장단위 : 1 Multi SFIT Ti-Base
- > Spread Fit™ 유지형 Cementless보철 제작으로 유지보수가 매우 용이
- > Angulated screw channel 형성 가능(최대 25°)
- > Multi A Abutment 사용 시 최대 110°까지 Fixture 식립 Path 보강
- > 심미성을 위한 Gold coloring
- > 3shape 및 Exocad용 라이브러리 제공(5µm 단위로 세분화)
- > Torx Driver와 Torque Wrench를 사용하여 체결
(Straight screw channel : Torx S Driver / Angulated screw channel : Torx A Driver)
- > 권장 체결 토크 : 25Ncm

Multi SFIT Ti Base Screw



Diameter	Ø2.3
Height	5.5
2SMCS100AF	

- > 포장단위 : 1 Multi SFIT Ti-Base Screw
- > Angulated screw channel 형성 가능(최대 25°)
- > Torx S Driver 또는 Torx A Driver 와 Torque Wrench를 사용하여 체결

Multi SFIT Setting Screw

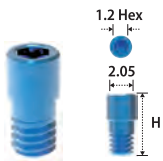

Diameter	Ø2.0
Height	4.3
2SMCSS100	

- > 포장단위 : 5 Multi SFIT Ti-Base Setting Screws
- > Multi SFIT Ti-Base 및 보철물 Adaptation 시 사용되는 기공용 Screw
- > Hex Driver를 사용하여 체결
- > 권장 체결 토크: Finger force

Multi SFIT Crown Gauge

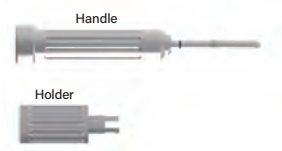

Code
SFMCG

- > 포장단위 : 1 Holder + 1 Handle
- > 기공과정에 사용되며 Multi SFIT Ti-Base의 Crown 내면 Under cut 확인

Spreader

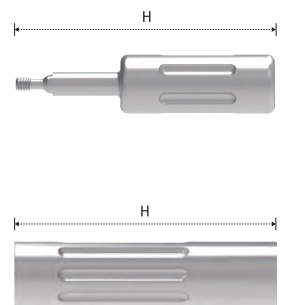

Type	Handle
Height	33.5
	2SMSFSP01H

Type	Connector
Height	30
	2SSFSP01C

- > Ti-Base와 Crown의 반복된 탈착으로 인하여 Spring의 유지력이 떨어질 경우 Spreader가 SFIT Ti-Base Spring부를 벌려 유지력을 복원
- > 유지력이 떨어진 상태에서 납품 시 셋팅 과정에서 SFIT Ti-Base와 크라운이 분리되어 셋팅 시 어려움 발생
- > 기공소에서 최종 어답 확인 후 치과납품 전 사용권장

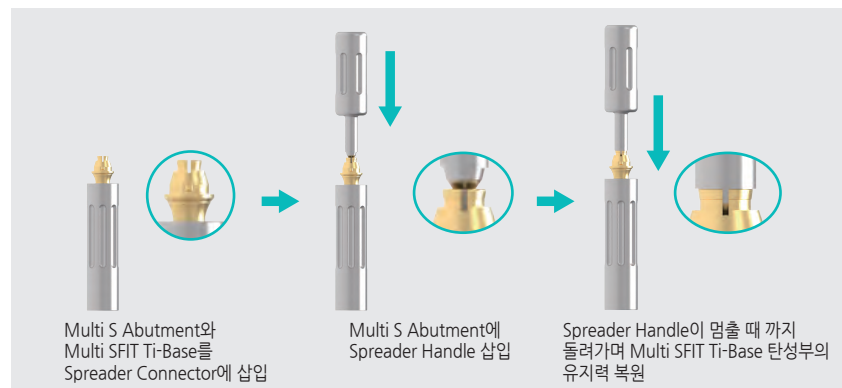

Component selection guide for the Sub. Hybrid Ti-Base System

- Intra-oral scanning
- Model-scanning

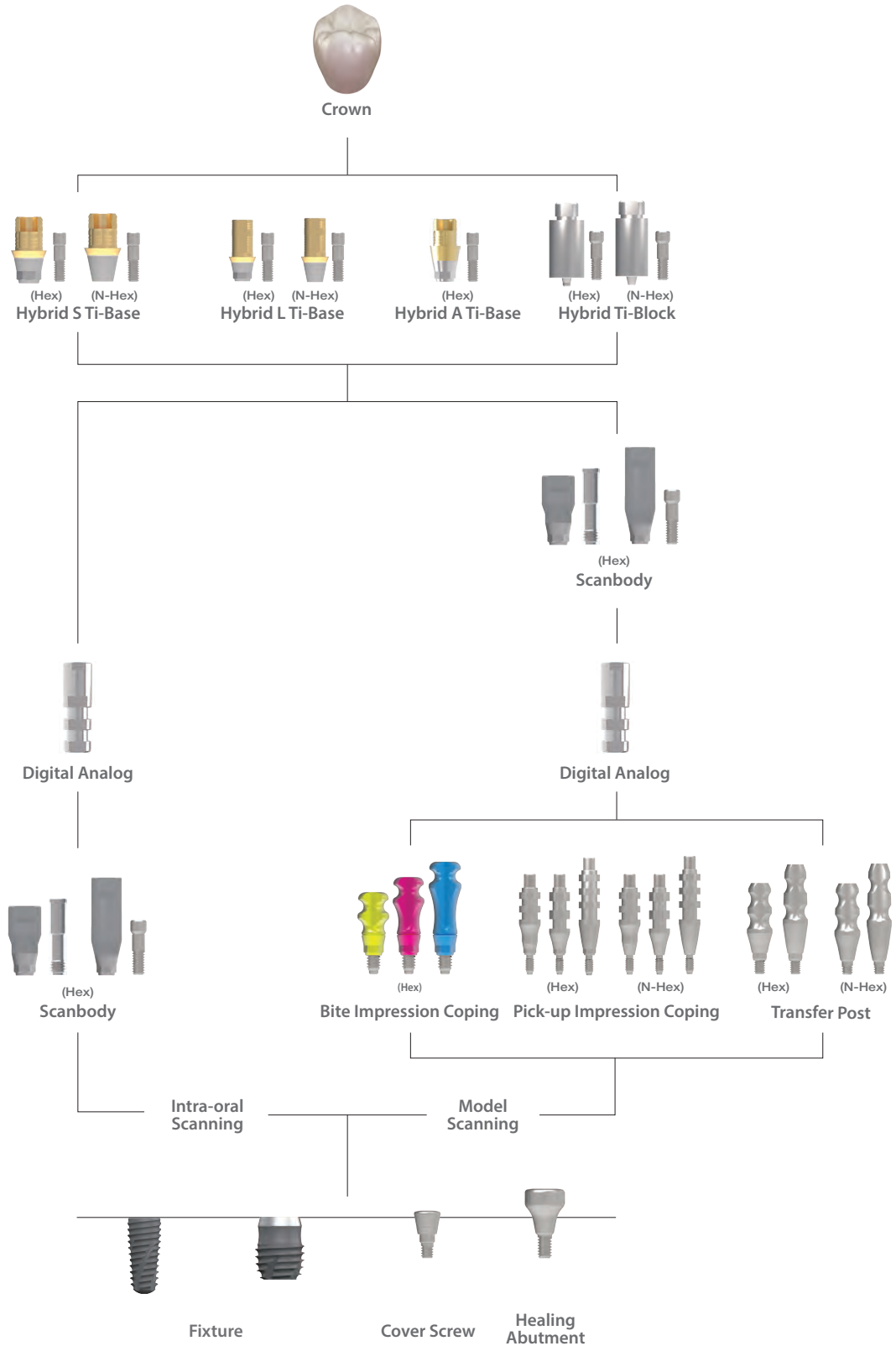

Hybrid S Ti-Base

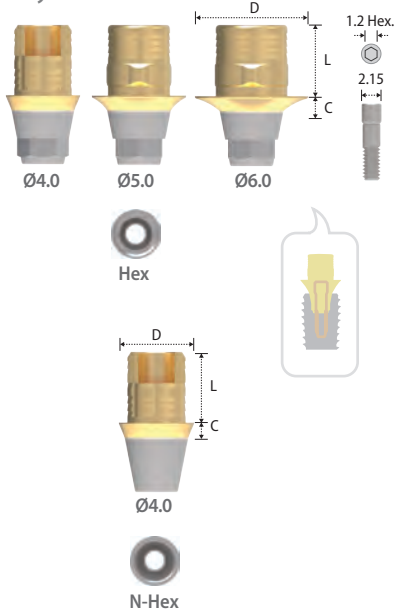

Type	Hex			N-Hex
Diameter	Ø4.0	Ø5.0	Ø6.0	Ø4.0
Length Cuff	3.75	3.75	3.75	3.75
0.8	2SLH404	2SLH504	2SLH604	2SLN404
2	2SLH424	2SLH524	2SLH624	2SLN424
3	2SLH434	2SLH534	2SLH634	2SLN434

- > 포장단위 : 1 Hybrid S Ti-Base + 1 Abutment Screw(2SSHR200)
- > CRP 및 SCRП 유지형 보철 제작
- > 회전방지 단면 부여
- > 심미성을 위한 Gold coloring
- > Scanbody 사용 시 Digital work 가능
- > 3shape, Exocad 및 Dental Wings용 라이브러리 제공
- > Hex Driver와 Torque Wrench로 체결
- > 권장 체결 토크 : 30Ncm
- > Fixture level impression

Hybrid L Ti-Base

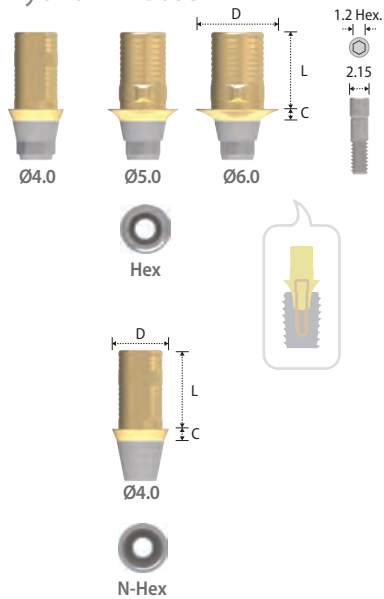

Type	Hex			N-Hex
Diameter	Ø4.0	Ø5.0	Ø6.0	Ø4.0
Length Cuff	5.5	5.5	5.5	5.5
1	2SLH415	2SLH515	2SLH615	2SLN415
2	2SLH425	2SLH525	2SLH625	2SLN425
3	2SLH435	2SLH535	2SLH635	2SLN435

- > 포장단위 : 1 Hybrid L Ti-Base + 1 Abutment Screw(2SSHR200)
- > CRP 및 SCRП 유지형 보철 제작
- > 회전방지 단면 부여
- > 심미성을 위한 Gold coloring
- > Scanbody 사용 시 Digital work 가능
- > 3shape, Exocad 및 Dental Wings용 라이브러리 제공
- > Hex Driver와 Torque Wrench로 체결
- > 권장 체결 토크 : 30Ncm
- > Fixture level impression

Hybrid A Ti-Base

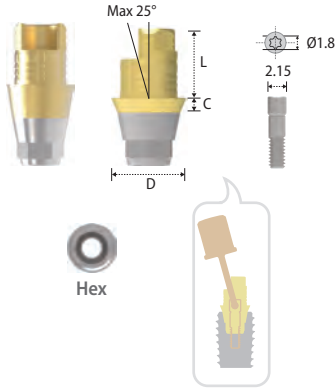

Type	Hex	N-Hex
Diameter	Ø4.0	Ø4.0
Length	3.75	3.75
Cuff		
0.8	2SLH404A	2SLN404A
2	2SLH424A	2SLN424A
3	2SLH434A	2SLN434A

- > 포장단위 : 1 Hybrid A Ti-Base + 1 Abutment Screw (2SLAH100 / 2SLAH200 / 2SLAH300)
- > CRP 및 SCRП 유지형 보철 제작
- > Angulated Screw Channel 25° 까지 작업 가능
- > 심미성을 위한 Gold coloring
- > Scanbody 사용 시 Digital work 가능
- > 3shape, Exocad 및 Dental Wings용 라이브러리 제공
- > Torx A Driver와 Torque Wrench로 체결
- > 권장 체결 토크 : 30Ncm
- > Fixture level impression

* Torx A Ratchet Driver

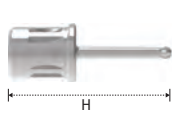

Height	Type	Ratchet
24(Short)		KRBUD15
29(Long)		KRBUD20

> Torx A Driver와 Torx 구조가 있는 Abutment Screw의 접촉면적이 넓어 Internal slip이나 파절 염려가 적음

Hybrid Ti-Block

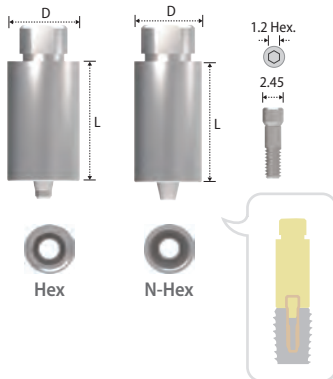

Type	Hex			N-Hex		
Diameter	10	12	14	10	12	14
Length						
20	CSHH10S	CSHH12S	CSHH14S	CSHN10S	CSHN12S	CSHN14S

- > 포장단위 : 1 Hybrid Ti-Block + 2 Abutment Screws (2SSHR100)
- > CRP 및 SCRП 유지형 보철 제작
- > 3shape, Exocad 및 Dental Wings용 라이브러리 제공
- > Hex Driver와 Torque Wrench로 체결
- > 권장 체결 토크 : 30Ncm
- > Fixture level impression

Scanbody

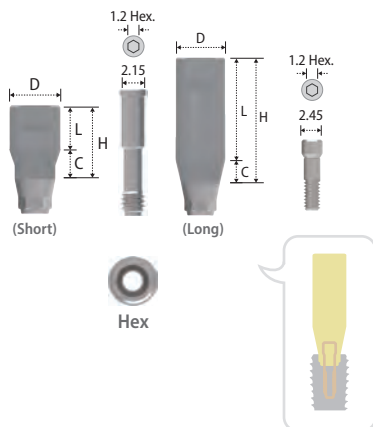

Type	Hex(Short)	Hex(Long)
Diameter	Ø4.3	Ø4.3
Height	6	11
Length		
Cuff	4	9
2	2SSB4325	2SSB4329

- > 포장단위 : 1 Scanbody + 1 Abutment Screw(2SSB100S / 2SSHR100)
- > 내구성이 뛰어나고 정밀한 공차로 정확한 Digital impression(Scanning)
- > 특수 코팅적용한 100% 티타늄 합금
- > Scan spray 및 Sand Blasting등의 과정이 불필요
- > 개구량 부족 하지 않거나 교합고경이 충분하다면 Long Scanbody 사용 권장
- > Hex Driver를 사용하여 체결
- > 권장 체결 토크 : 12~15Ncm
- > Fixture level impression

Bite Impression Coping



Type	Hex(Short)	Hex(Long)	Hex(X-Long)
Diameter	Ø4.5	Ø4.5	Ø4.5
Length / Cuff	2	4	6
	4.0 2SBIC45S	2SBIC45L	2SBIC45X

- > 포장단위 : 1 Bite Impression Coping (Inbuilt Guide Pin)
- > Bite tray 사용
- > Bite와 Impression 동시 채득 가능
- > Hex Driver를 사용하여 체결
- > 권장 체결 토크 : 12~15Ncm
- > Fixture level impression

Pick-up Impression Coping

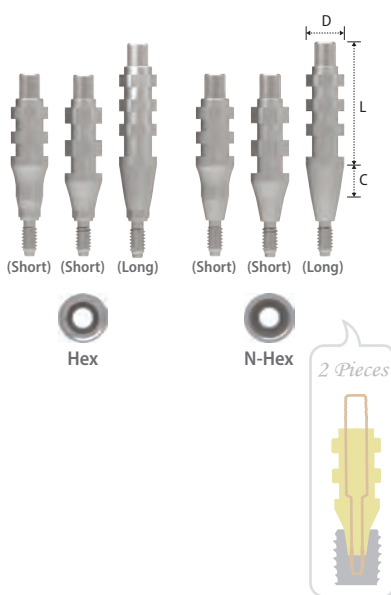

Type	Hex			N-Hex		
Diameter / Length / Cuff	Ø4.5	Ø5.5	Ø6.5	Ø4.5	Ø5.5	Ø6.5
12 (Short) / 4	2SIH454S	2SIH554S	2SIH654S	2SIN454S	2SIN554S	2SIN654S
14 (Short) / 2	2SIH45S	2SIH55S	2SIH65S	2SIN45S	2SIN55S	2SIN65S
16 (Long) / 4	2SIH45L	2SIH55L	2SIH65L	2SIN45L	2SIN55L	2SIN65L

- > 포장단위 : 1 Pick-up Impression Coping + 1 Guide Pin(2SISR001SS / 2SISR001SL)
- > Open tray 사용(Custom tray)
- > Hex Driver를 사용하여 체결
- > 권장 체결 토크 : 12~15Ncm
- > Fixture level impression

Transfer Post

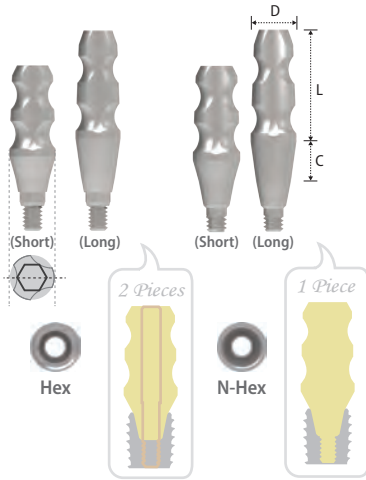

Type	Hex			N-Hex		
<i>Diameter</i> <i>Length / Cuff</i>	Ø4.5	Ø5.5	Ø6.5	Ø4.5	Ø5.5	Ø6.5
9 (Short) / 2	2STH45S	2STH55S	2STH65S	2STN45S	2STN55S	2STN65S
11 (Long) / 4	2STH45L	2STH55L	2STH65L	2STN45L	2STN55L	2STN65L

- > 포장단위 : Hex- 1 Transfer Post + 1 Guide Pin(2STH001SS / 2STH001SL)
N-Hex- 1 Transfer Post(Solid type)
- > Closed tray 사용
- > Hex Driver를 사용하여 체결
- > 권장 체결 토크 : 12~15Ncm
- > Fixture level impression

Digital Analog



<i>Diameter</i> <i>Height</i>	Ø3.9
12	2SDR001

- > 포장단위 : 1 Digital Analog
- > 작업모형 상에 Fixture 형상 구현
- > 3D printing(RP) 및 석고모형에 사용

Abutment Screw

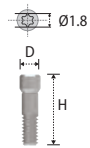
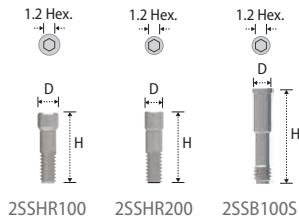

<i>Diameter</i> <i>Height</i>	Ø2.45	Ø2.15	Ø2.15
8.5	2SSHR100	2SSHR200	
10.7			2SSB100S

- > 2SSHR100 : Hybrid Block and Scanbody (2SSB4329)
- > 2SSHR200 : Hybrid S Ti-Base, Hybrid L Ti-Base
- > 2SSHR100S : Scanbody (2SSB4325)
- > Hex Driver와 Torque Wrench로 체결

<i>Diameter</i> <i>Height</i>	2	3.2	4.2
Ø2.15	2SLAH100	2SLAH200	2SLAH300

- > 포장단위 : 1 Abutment Screw
- > Hybrid A Ti-Base용
- > Angulated Screw Channel 25° 까지 작업 가능
- > Torx A Driver와 Torque Wrench로 체결

Component selection guide for the Sub. Multi Hybrid Ti-Base System

- Intra-oral scanning
- Model-scanning

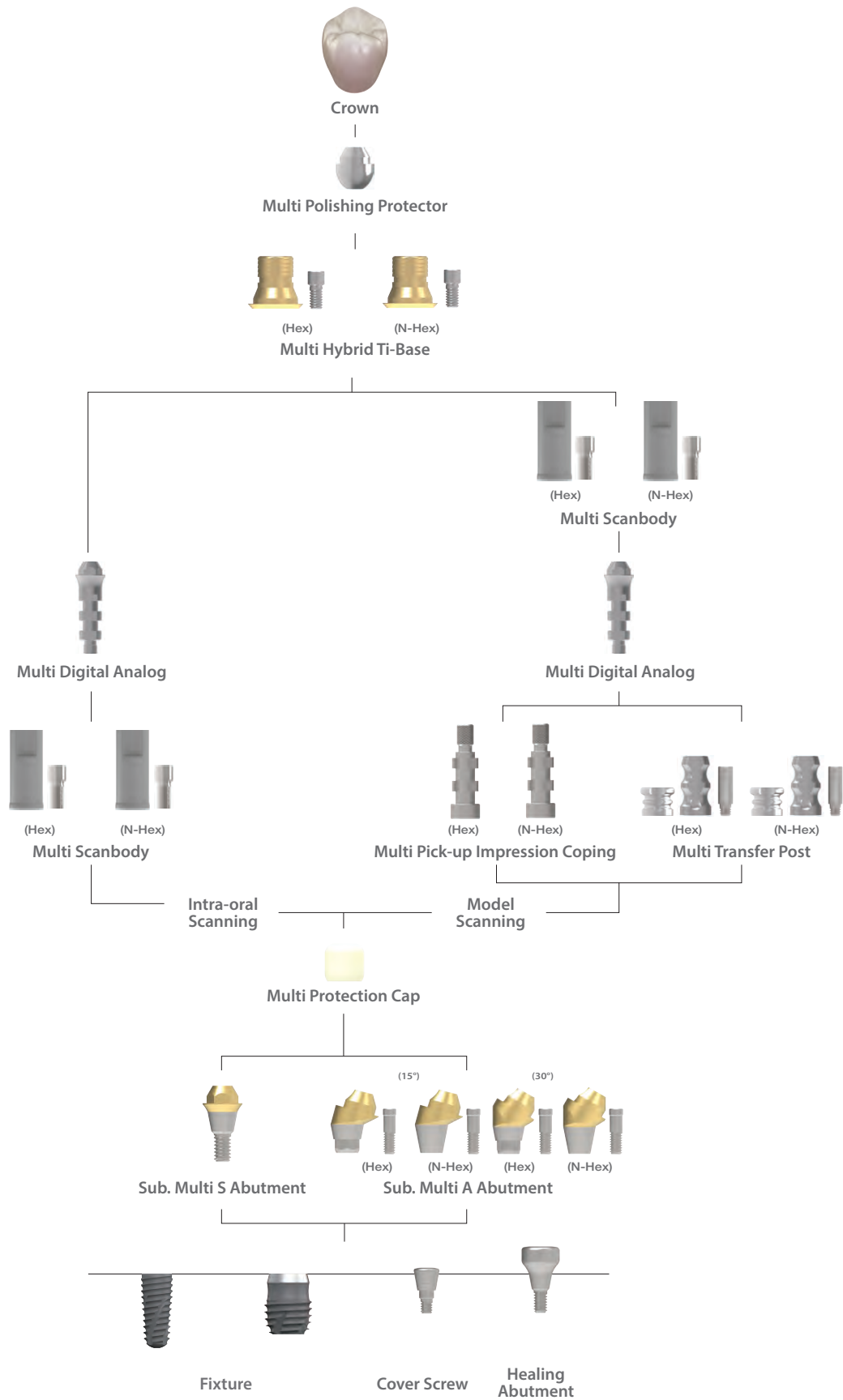

Multi S Abutment

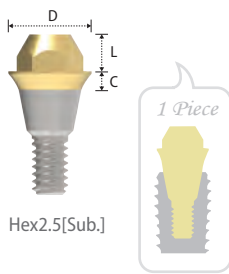

Hex2.5[Sub.]

Fixture Connection	Hex2.5[Sub.]	
Platform[Fixture Dia.]	Ø4.5 [Ø3.5 / Ø4.0 / Ø4.5 / Ø5.0 / Ø6.0]	
Diameter	Ø4.5	Ø5.5
Cuff / Length	2	2
1	2SMS451	2SMS551
2	2SMS452	2SMS552
3	2SMS453	2SMS553
4	2SMS454	2SMS554
5	2SMS455	2SMS555

- > 포장단위 : 1 Multi S Abutment
- > SRP 유지형 보철 제작
- > Multi Hybrid Ti-Base를 위한 Titanium-Base
- > Screw와 Abutment의 일체형 구조(Solid type)
- > 심미성을 위한 Gold coloring
- > Scanbody 사용 시 Digital work 가능
- > 3shape 및 Exocad용 라이브러리 제공
- > Multi S Holder를 사용하여 구강 내 Delivery
- > Multi S Driver와 Torque Wrench를 사용하여 체결
- > 권장 체결 토크 : 30Ncm
- > Abutment level impression

Multi A Abutment

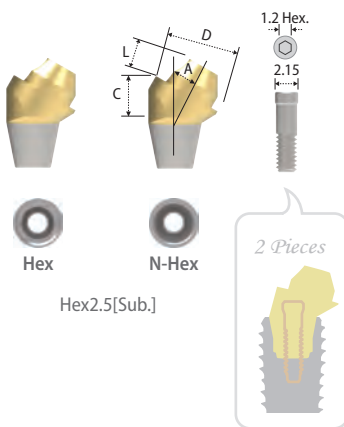

Hex
N-Hex
Hex2.5[Sub.]

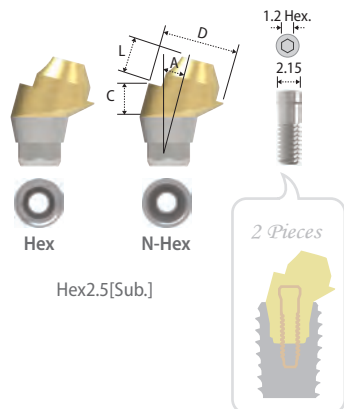

Hex
N-Hex
Hex2.5[Sub.]

Type	Hex			
Fixture Connection	Hex2.5[Sub.]			
Platform[Fixture Dia.]	Ø4.5 [Ø3.5 / Ø4.0 / Ø4.5 / Ø5.0 / Ø6.0]		Ø5.5 [Ø3.5 / Ø4.0 / Ø4.5 / Ø5.0 / Ø6.0]	
Diameter(Angle)	Ø4.5(15°)	Ø4.5(30°)	Ø5.5(15°)	Ø5.5(30°)
Cuff / Length	2	2	2	2
2	● 2SMAH45152			
3	★ 2SMAH45153	● 2SMAH45303	★ 2SMAH55153	★ 2SMAH55303
4	★ 2SMAH45154	★ 2SMAH45304	★ 2SMAH55154	★ 2SMAH55304
5			★ 2SMAH55155	★ 2SMAH55305

Type	N-Hex			
Fixture Connection	Hex2.5[Sub.]			
Platform[Fixture Dia.]	Ø4.5 [Ø3.5 / Ø4.0 / Ø4.5 / Ø5.0 / Ø6.0]		Ø5.5 [Ø3.5 / Ø4.0 / Ø4.5 / Ø5.0 / Ø6.0]	
Diameter(Angle)	Ø4.5(15°)	Ø4.5(30°)	Ø5.5(15°)	Ø5.5(30°)
Cuff / Length	2	2	2	2
2	● 2SMAN45152			
3	★ 2SMAN45153	● 2SMAN45303	★ 2SMAN55153	★ 2SMAN55303
4	★ 2SMAN45154	★ 2SMAN45304	★ 2SMAN55154	★ 2SMAN55304
5			★ 2SMAN55155	★ 2SMAN55305

- > 포장단위 : 1 Multi A Abutment + Abutment Screw(2SSHR300: ★, 2SSHR400: ●)
- > SRP 유지형 보철 제작
- > Multi Hybrid Ti-Base를 위한 Titanium-Base
- > Fixture path 보상(2개의 fixture 기준 최대 90°)
- > 심미성을 위한 Gold coloring
- > Scanbody 사용 시 Digital work 가능
- > 3shape 및 Exocad용 라이브러리 제공
- > Multi A Holder를 사용하여 구강 내 Delivery
- > Hex Driver와 Torque Wrench를 사용하여 체결
- > 권장 체결 토크 : 30Ncm
- > Abutment level impression

Abutment Screw

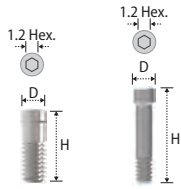

Height	7.5	6.5
Diameter	2.15	2.25
	★ 2SSHR300	● 2SSHR400

- > 포장단위 : 1 Abutment Screw
- > Multi A Abutment 체결 시 사용
- > Hex Driver와 Torque Wrench를 사용하여 체결

Multi Protection Cap

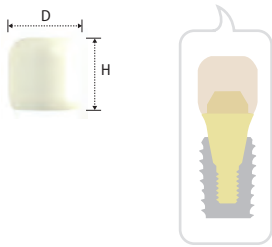

Multi S & A Abutment Diameter	Ø4.5	Ø5.5
Diameter	Ø5.2	Ø6.2
Height	5	5
	2SMPC45	2SMPC55

- > 포장단위 : 1 Multi Protection Cap
- > 치유기간 중 구강 내 Abutment를 보호하고 환자의 이물감을 최소화
- > Abutment의 보철 마진을 형성하기 위한 Gingival retraction에 사용
- > 임시 보철의 하부구조로 사용 가능
- > Hex Driver로 체결
- > 권장 체결 토크 : 5~10Ncm

Multi Scanbody

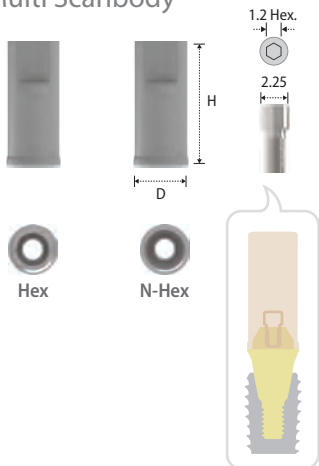

Type	Hex	N-Hex
Multi S & A Abutment Diameter	Ø4.5 & Ø5.5	Ø4.5 & Ø5.5
Diameter	Ø4.5	Ø4.5
Height	9	9
	2SMB001H	2SMB001N

- > 포장단위 : 1 Scanbody + 1 Multi Cylinder Screw(2SMCS100)
- > 내구성이 뛰어나고 정밀한 공차로 정확한 Digital impression(Scanning)
- > 특수 코팅적용한 100% 티타늄 합금
- > Scan spray 및 Sand Blasting등의 과정이 불필요
- > Hex Driver를 사용하여 체결
- > 권장 체결 토크 : 12~15Ncm
- > Abutment level impression

Multi Pick-up Impression Coping

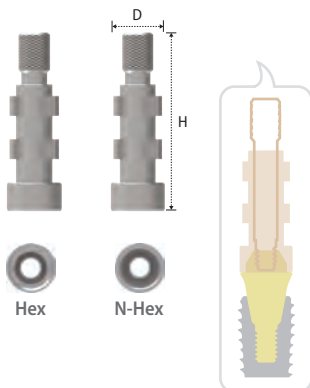

Type	Hex		N-Hex	
Multi S & A Abutment Diameter	Ø4.5	Ø5.5	Ø4.5	Ø5.5
Diameter	Ø4.65	Ø5.65	Ø4.65	Ø5.65
Height	16	16	16	16
	2SMIH45	2SMIH55	2SMIN45	2SMIN55

- > 포장단위 : 1 Multi Pick-up Impression Coping + 1 Guide Pin(2SMGP012)
- > Open tray 사용(Custom tray)
- > Hex Driver를 사용하여 체결
- > 권장 체결 토크 : 12~15Ncm
- > Abutment level impression

Multi Transfer Post

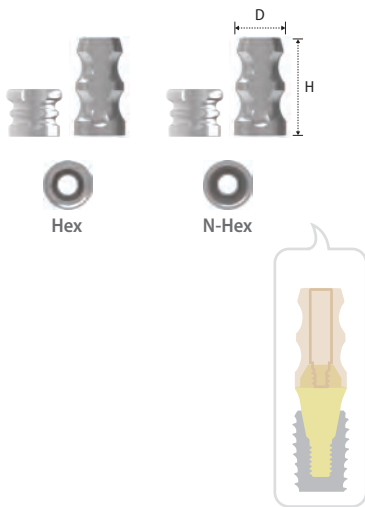

Type	Hex		N-Hex	
Multi S&A Abutment Diameter	Ø4.5	Ø5.5	Ø4.5	Ø5.5
Diameter / Height	Ø4.5	Ø5.5	Ø4.5	Ø5.5
5	2SMTH455	2SMTH555	2SMTN455	2SMTN555
8.5	2SMTH45	2SMTH55	2SMTN45	2SMTN55

- > 포장단위 : 1 Multi Transfer Post + 1 Guide Pin(2SMTHS100)
- > Closed tray 사용
- > Hex Driver를 사용하여 체결
- > 권장 체결 토크 : 12~15Ncm
- > Abutment level impression

Multi Digital Analog



Multi S&A Abutment Diameter	Ø4.5	Ø5.5
Diameter / Length	Ø4.5	Ø5.5
2	2SMLA45	2SMLA55

- > 포장단위 : 1 Multi Digital Analog
- > 작업모형 상에 Abutment 형상 구현
- > 3D printing(RP) 및 석고모형에 사용

Multi Hybrid Ti-Base

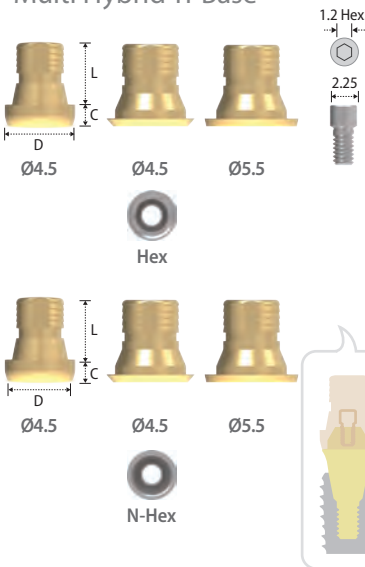

Type	Hex			N-Hex		
Multi S&A Abutment Diameter	Ø4.5	Ø4.5	Ø5.5	Ø4.5	Ø4.5	Ø5.5
Diameter / Length	Ø4.5	Ø4.5	Ø5.5	Ø4.5	Ø4.5	Ø5.5
Cuff	4.5	4.5	4.5	4.5	4.5	4.5
0.5	2SMHT45H	2SMHT55H		2SMHT45N	2SMHT55N	
1.5	2SMHT40H			2SMHT40N		

- > 포장단위 : 1 Multi Hybrid Ti-Base + 1 Multi Cylinder Screw (2SMCS100)
- > CRP 및 SCRП 유지형 보철 제작
- > 회전방지 단면 부여
- > 심미성을 위한 Gold coloring
- > Scanbody 사용 시 Digital work 가능
- > 3shape, Exocad 및 Dental Wings용 라이브러리 제공
- > Hex Driver와 Torque Wrench로 체결
- > 권장 체결 토크 : 20Ncm
- > Abutment level impression

Multi Cylinder Screw

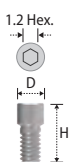

Diameter / Height	Ø2.25
5	2SMCS100

- > 포장단위 : 1 Multi Cylinder Screw
- > Multi Scanbody 및 Multi Hybrid Ti-Base용
- > Hex Driver와 Torque Wrench로 체결
- > 권장 체결 토크 : 20Ncm

Component selection guide for the Sub-N. Hybrid Ti-Base System

- Intra-oral scanning
- Model-scanning

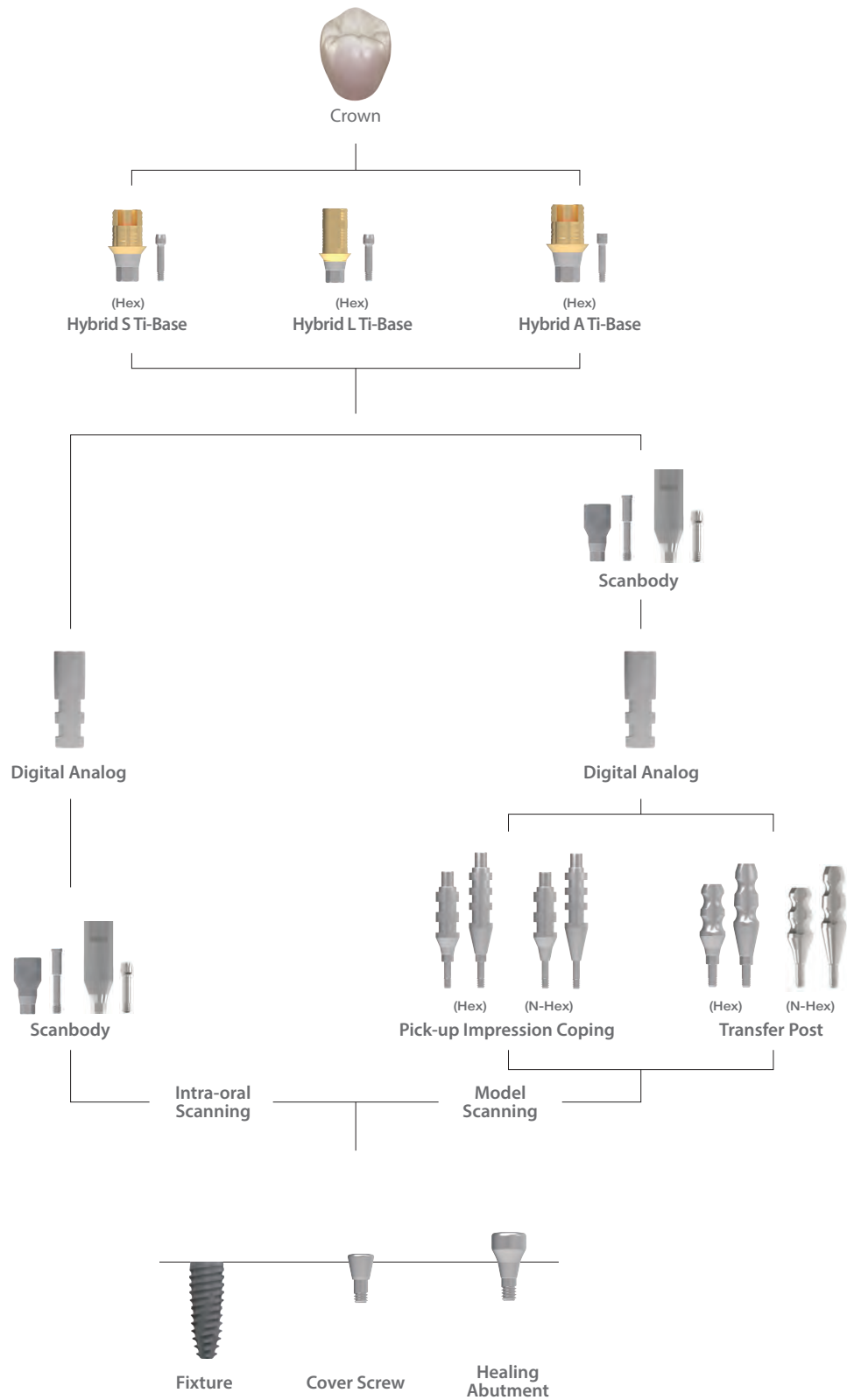

Hybrid S Ti-Base

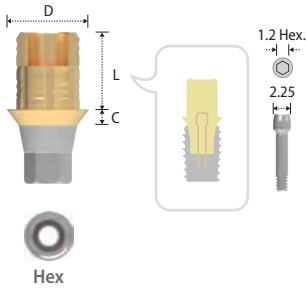

Type	Hex
Diameter	Ø4.0
Length / Cuff	3.75
0.8	SLH404N
2	SLH424N
3	SLH434N

- > 포장단위 : 1 Hybrid S Ti-Base + 1 Abutment Screw(SSHR100N)
- > CRP 및 SCRП 유지형 보철 제작
- > 회전방지 단면 부여
- > 심미성을 위한 Gold coloring
- > Scanbody 사용 시 Digital work 가능
- > 3shape, Exocad 및 Dental Wings용 라이브러리 제공
- > Hex Driver와 Torque Wrench로 체결
- > 권장 체결 토크 : 20~25Ncm
- > Fixture level impression

Hybrid L Ti-Base

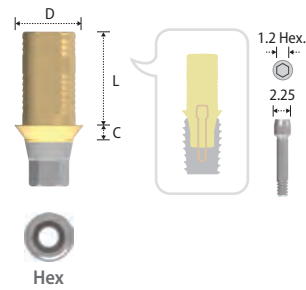

Type	Hex
Diameter	Ø4.0
Length / Cuff	5.5
1	SLH415N
2	SLH425N
3	SLH435N

- > 포장단위 : 1 Hybrid L Ti-Base + 1 Abutment Screw(SSHR100N)
- > CRP 및 SCRП 유지형 보철 제작
- > 회전방지 단면 부여
- > 심미성을 위한 Gold coloring
- > Scanbody 사용 시 Digital work 가능
- > 3shape, Exocad 및 Dental Wings용 라이브러리 제공
- > Hex Driver와 Torque Wrench로 체결
- > 권장 체결 토크 : 20~25Ncm
- > Fixture level impression

Hybrid A Ti-Base

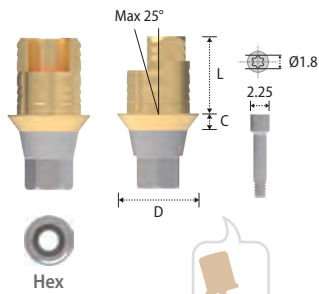

Type	Hex	N-Hex
Diameter	Ø4.0	Ø4.0
Length / Cuff	3.75	3.75
0.8	SLH404AN	SLN404AN
2	SLH424AN	SLN424AN
3	SLH434AN	SLN434AN

- > 포장단위 : 1 Hybrid A Ti-Base + 1 Abutment Screw (SLAH100N / SLAH200N / SLAH300N)
- > CRP 및 SCRП 유지형 보철 제작
- > Angulated Screw Channel 25° 까지 작업 가능
- > 심미성을 위한 Gold coloring
- > Scanbody 사용 시 Digital work 가능
- > 3shape, Exocad 및 Dental Wings용 라이브러리 제공
- > Torx A Driver와 Torque Wrench로 체결
- > 권장 체결 토크 : 20~25Ncm
- > Fixture level impression

*Torx A Ratchet Driver

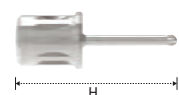

Height	Type	Ratchet
24(Short)		KRBUD15
29(Long)		KRBUD20

- > Torx A Driver와 Angulated screw channel용 Torx 구조가 있는 Abutment Screw의 접촉면적이 넓어 Internal slip이나 파결 염려가 적음
- > 25° 기준 최대 토크 50Ncm

Scanbody

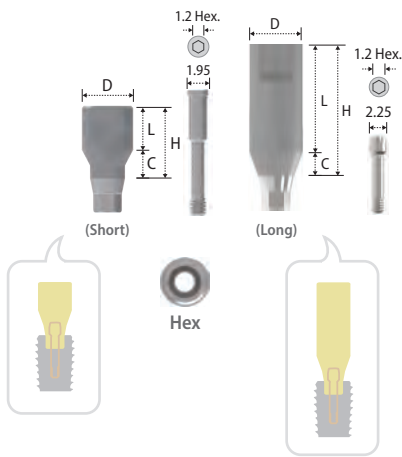

Type	Hex(Short)	Hex(Long)
Diameter	Ø4.3	Ø4.3
Height	6	11
Length / Cuff	4	9
2	SSB4325N	SSB4329N

- > 포장단위 : 1 Scanbody + 1 Abutment Screw
- > 모델스캐너 및 구강스캐너 모두 사용 가능
- > 특수 코팅적용한 100% 티타늄 합금
- > Scan spray 및 Sand Blasting등의 과정이 불필요
- > Hex Driver와 Torque Wrench로 체결
- > 권장 체결 토크 : 12~15Ncm

Pick-up Impression Coping

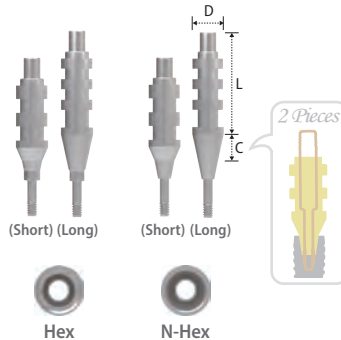

Type	Hex	N-Hex
Diameter	Ø4.5	Ø4.5
Length / Cuff		
14 (Short) / 2	SIH45SN	SIN45SN
16 (Long) / 4	SIH45LN	SIN45LN

- > 포장단위 : 1 Pick-up Impression Coping + 1 Guide Pin
- > Open tray impression
- > Guide Pin (SIS001SN/SIS001LN)으로 체결
- > Hex Driver와 Torque Wrench로 체결
- > 권장 체결 토크 : 12~15Ncm

Transfer Post

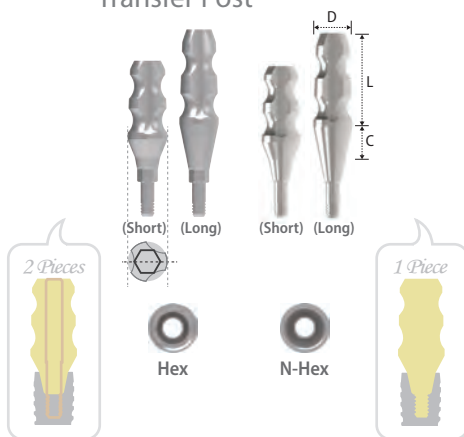

Type	Hex	N-Hex
Diameter	Ø4.5	Ø4.5
Length / Cuff		
9 (Short) / 2	STH45SN	STN45SN
11 (Long) / 4	STH45LN	STN45LN

- > 포장단위 : 1 Transfer Post + 1 Guide Pin / N-Hex - 1 Transfer Post (Solid Type)
- > Closed tray impression
- > Guide Pin (STS001SN/STS001LN)으로 체결
- > Hex Driver와 Torque Wrench로 체결
- > 권장 체결 토크 : 12~15 Ncm

Digital Analog



<i>Diameter</i>	Ø3.9	
<i>Height</i>	12	SDR001N

- > 포장단위 : 1 Digital Analog
- > 작업모형 상에 Fixture 형상 구현
- > 3D printing(RP) 및 석고모형에 사용

Abutment Screw

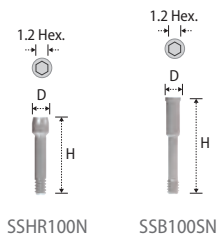

<i>Diameter</i>	Ø2.25	Ø1.95
<i>Height</i>	10.2	SSHR100N
	12.3	SSB100SN

- > 포장단위 : 1 Abutment Screw
- > SSHR100N : Hybrid S Ti-Base, Hybrid L Ti-Base, Scanbody (SSB4329N)
- > SSB100SN : Scanbody (SSB4325N)
- > Hex Driver와 Torque Wrench로 체결
- > 권장 체결 토크 : 20~25Ncm

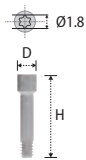

<i>Height</i>	10.2	11.4	12.4
<i>Diameter</i>	Ø2.25	SLAH100N	SLAH200N
			SLAH300N

- > 포장단위 : 1 Abutment Screw
- > Hybrid A Ti-Base용
- > Angulated Screw Channel 25° 까지 작업 가능
- > Torx A Driver와 Torque Wrench로 체결

COWELL EXPERT KITS

Experts know what makes them experts

• SURGICAL KITS

- INNO SUB. FULL SURGICAL KIT
- INNO INT. FULL SURGICAL KIT
- INNO EXT. FULL SURGICAL KIT
- INNO SUB. SHORT SURGICAL KIT
- INNO SUB. NARROW SURGICAL KIT
- MINI PLUS SURGICAL KIT
- INNO PROSTHETIC PLANNING KIT
- INNO PROSTHETIC INSTRUMENT KIT



• DIGITAL GUIDED SURGERY KITS

- Lodestar Plus Kit
- Lodestar Kit
- Lodestar Sinus Kit



• **COWELL EXPERT INSTRUMENT KITS**

- MFS Kit (Multi-Functional Sinus Kit)
- ESL Kit (Easy Sinus Lift Kit)
- MFR Kit (Multi-Functional Removal Kit)
- InnoGenic GBR Kit
- Bone Profiler Kit
- InnoGenic Autobone Harvester
- COWELL BMP Trepine Kit
- Atraumatic Extraction Kit
- AO4 Surgical Stent
- Volume-up Guide System

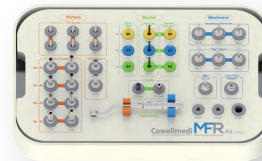

INNO SUB. FULL SURGICAL KIT [KCA010F]



- > INNO Submerged Implant System(Sub.)
- > Fixture Driver 및 Depth Gauge의 치은 높이 측정부 제외 전 구성품 Sub. Int. 및 Ext. 공용



Ø3.5 Fixture Final Drill Ø4.0 Fixture Final Drill Ø4.5 Fixture Final Drill Ø5.0 Fixture Final Drill Ø6.0 Fixture Final Drill

		<p>* A common tool for Sub. / Int. / Ext. An exclusive tool by type</p>					

INNO INT. FULL SURGICAL KIT [KCA010FI]



- > INNO Internal Implant System(Int.)
- > Fixture Driver 제외 전 구성품 Sub. Int. 및 Ext. 공용



Path Drill 2KTD18	Point Drill KPD01S	Parallel Pin KPP002	Parallel Pin KPP002	1.2 Hex Driver L KHD1221	1.2 Hex Driver XL KHD1227	M. Mount Driver L KMMD06L	R. Mount Driver L KRMD19L	M. Fixture Driver S KMMI01S	R. Fixture Driver S KHD101S	M. Fixture Driver L KMMI01L	R. Fixture Driver L KHD101L	Drill Extension KDE002	Depth Gauge KDG001	
Ø2.2 X 7 KPSD2207	Ø2.2 X 8 KPSD2208	Ø2.2 X 10 KPSD2210	Ø2.2 X 12 KPSD2212	Ø2.2 X 14 KPSD2214	Ø3.5 X 7 2KTD3707	Ø3.5 X 8 2KTD3708	Ø3.5 X 10 2KTD3710	Ø3.5 X 12 2KTD3712	Ø3.5 X 14 2KTD3714	Ø3.5 X 7 2KTD3707	Ø3.5 X 8 2KTD3708	Ø3.5 X 10 2KTD3710	Ø3.5 X 12 2KTD3712	Ø3.5 X 14 2KTD3714
Ø4.0 X 7 2KTD4007	Ø4.0 X 8 2KTD4008	Ø4.0 X 10 2KTD4010	Ø4.0 X 12 2KTD4012	Ø4.0 X 14 2KTD4014	Ø4.0 X 7 2KTD4007	Ø4.0 X 8 2KTD4008	Ø4.0 X 10 2KTD4010	Ø4.0 X 12 2KTD4012	Ø4.0 X 14 2KTD4014	Ø4.0 X 7 2KTD4007	Ø4.0 X 8 2KTD4008	Ø4.0 X 10 2KTD4010	Ø4.0 X 12 2KTD4012	Ø4.0 X 14 2KTD4014
Ø4.5 X 7 2KTD4507	Ø4.5 X 8 2KTD4508	Ø4.5 X 10 2KTD4510	Ø4.5 X 12 2KTD4512	Ø4.5 X 14 2KTD4514	Ø4.5 X 7 2KTD4507	Ø4.5 X 8 2KTD4508	Ø4.5 X 10 2KTD4510	Ø4.5 X 12 2KTD4512	Ø4.5 X 14 2KTD4514	Ø4.5 X 7 2KTD4507	Ø4.5 X 8 2KTD4508	Ø4.5 X 10 2KTD4510	Ø4.5 X 12 2KTD4512	Ø4.5 X 14 2KTD4514
Ø5.0 X 7 2KTD5007	Ø5.0 X 8 2KTD5008	Ø5.0 X 10 2KTD5010	Ø5.0 X 12 2KTD5012	Ø5.0 X 14 2KTD5014	Ø5.0 X 7 2KTD5007	Ø5.0 X 8 2KTD5008	Ø5.0 X 10 2KTD5010	Ø5.0 X 12 2KTD5012	Ø5.0 X 14 2KTD5014	Ø5.0 X 7 2KTD5007	Ø5.0 X 8 2KTD5008	Ø5.0 X 10 2KTD5010	Ø5.0 X 12 2KTD5012	Ø5.0 X 14 2KTD5014
Ø6.0 X 7 2KTD6007	Ø6.0 X 8 2KTD6008	Ø6.0 X 10 2KTD6010	Ø6.0 X 12 2KTD6012	Ø6.0 X 14 2KTD6014	Ø6.0 X 7 2KTD6007	Ø6.0 X 8 2KTD6008	Ø6.0 X 10 2KTD6010	Ø6.0 X 12 2KTD6012	Ø6.0 X 14 2KTD6014	Ø6.0 X 7 2KTD6007	Ø6.0 X 8 2KTD6008	Ø6.0 X 10 2KTD6010	Ø6.0 X 12 2KTD6012	Ø6.0 X 14 2KTD6014
Ø3.5 Countersink 4KCS35	Ø4.0 Countersink 4KCS40	Ø4.5 Countersink 4KCS45	Ø5.0 Countersink 4KCS50	Ø6.0 Countersink 4KCS60	Ø3.5 Countersink 4KCS35	Ø4.0 Countersink 4KCS40	Ø4.5 Countersink 4KCS45	Ø5.0 Countersink 4KCS50	Ø6.0 Countersink 4KCS60	Ø3.5 Countersink 4KCS35	Ø4.0 Countersink 4KCS40	Ø4.5 Countersink 4KCS45	Ø5.0 Countersink 4KCS50	Ø6.0 Countersink 4KCS60

* A common tool for Sub. / Int. / Ext. An exclusive tool by type

INNO EXT. FULL SURGICAL KIT [KCA010FE]



- > INNO External Implant System(Ext.)
- > Fixture Driver 제외 전 구성품 Sub. Int. 및 Ext. 공용



○ Ø3.5 Fixture Final Drill
 ○ Ø4.0 Fixture Final Drill
 ○ Ø4.5 Fixture Final Drill
 ○ Ø5.0 Fixture Final Drill
 ○ Ø6.0 Fixture Final Drill

Ext. Fixture Driver							

* A common tool for Sub. / Int. / Ext. An exclusive tool by type

01



Drill / Surgical Tool

Point Drill

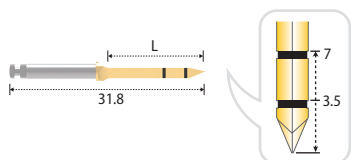

- > Cortical Bone에 천공 위치를 선정하여 초기 Drilling을 용이
- > 골재생술 시 치유에 필요한 신생혈관의 성장을 위해 주변 수용부의 단단한 골조직 천공

Length	15
KPD01S	

Path Drill

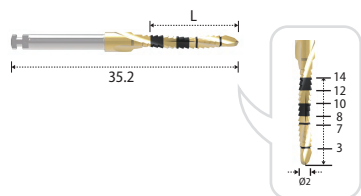

- > Drilling 시 식립 Path를 수정해야할 경우 사용

Length	15
2KTD18	

Initial Drill

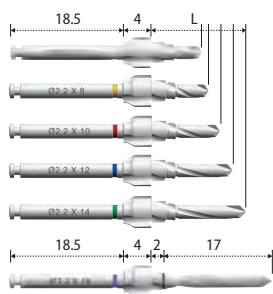

- Length band
- 7mm Fixture
- 8mm Fixture
- 10mm Fixture
- 12mm Fixture
- 14mm Fixture
- 16&18mm Fixture

Length	8	9	11	13	15	17&19
	KPSD2207	KPSD2208	KPSD2210	KPSD2212	KPSD2214	*KPSD2218

*별도판매

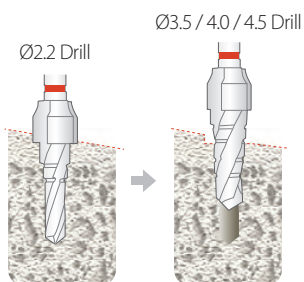

Final Drill 기진입량 확보

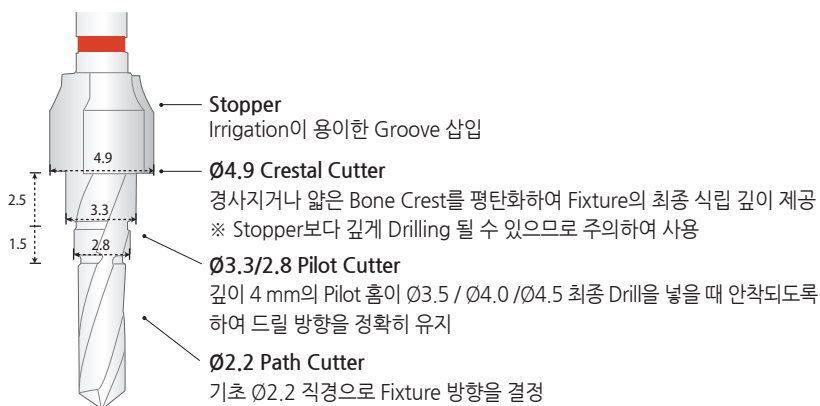

Final Drill

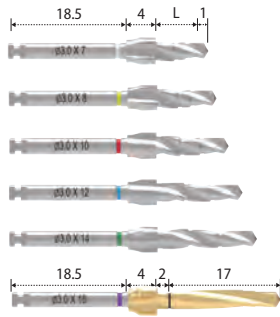

> 7, 8, 10, 12, 14, 16, 18mm Fixture의 각 직경별 Final Drill

Fixture Dia. Length	Ø3.0	Ø3.5	Ø4.0	Ø4.5	Ø5.0	Ø6.0
7	*2KTD3007	2KTD3707	2KTD4007	2KTD4507	2KTD5007	2KTD6007
8	*2KTD3008	2KTD3708	2KTD4008	2KTD4508	2KTD5008	2KTD6008
10	*2KTD3010	2KTD3710	2KTD4010	2KTD4510	2KTD5010	2KTD6010
12	*2KTD3012	2KTD3712	2KTD4012	2KTD4512	2KTD5012	2KTD6012
14	*2KTD3014	2KTD3714	2KTD4014	2KTD4514	2KTD5014	
16&18	*2KTD3018	*2KTD3718	*2KTD4018	*2KTD4518		

* 별도판매

Countersink

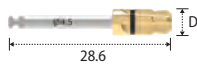

> Hard bone에서 Cortical bone 삭제(hole 확장) 시 사용

Fixture Dia.	Ø3.5	Ø4.0	Ø4.5	Ø5.0	Ø6.0
Diameter	Ø3.7	Ø4.2	Ø4.6	Ø5.1	Ø6.0
	4KCS35	4KCS40	4KCS45	4KCS50	4KCS60

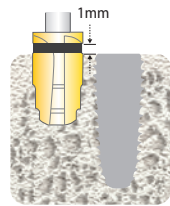

Fixture 상부가
치조골연과 일치
하게 매식

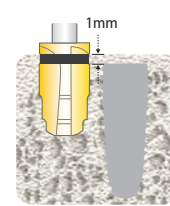

치조골연 아래로
1mm 이상 깊게
매식

1mm 깊게 식립할 경우 Marking Line 상단선까지 Drilling

* 골질이 너무 단단하여 Fixture 식립이 완전하게 되지 않을 경우 카운터 싱크 상단까지 Drilling

Multi Countersink

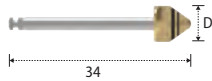

Diameter	Ø6.5
	4KCS01

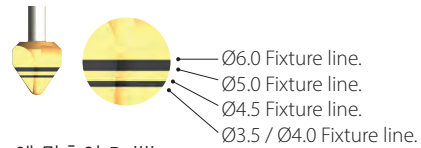

> External 전용 Countersink

> Fixture 직경별 Laser marking에 맞추어 Drilling

Tap Drill



> D1이상의 Hard Bone일 경우 선택적 사용

Fixture Dia.	Ø3.5	Ø4.0	Ø4.5	Ø5.0	Ø6.0
	*3KMTD35A	*3KMTD40A	*3KMTD45A	*3KMTD50A	*3KMTD60A

* 별도판매

Parallel Pin

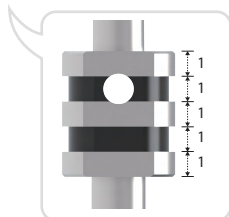
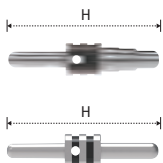

잇몸높이 확인용
Marking Line(1~5mm)

> Fixture의 위치와 방향 확인 시 사용

> 중간의 작은 관통 구멍에 실을 꿰어 구강안에서 떨어뜨릴 경우 삼키지 않도록 함

Height	21
	KPP002
	* KPP002P

* 별도판매

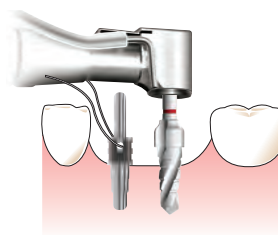
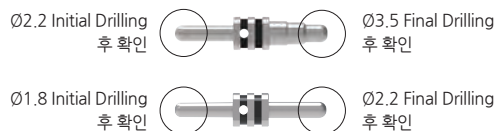

Drill Extension

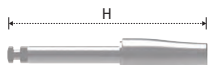

Height	27.5
	KDE002



Drill을 삽입한 후 회전하여 딸깍 소리가 나면 체결 완료

> Hand Piece용 Tool의 길이 연장

> 부정확한 체결상태로 무리한 힘을 가할 시 끼거나 휘고 파절이 발생할 수 있음

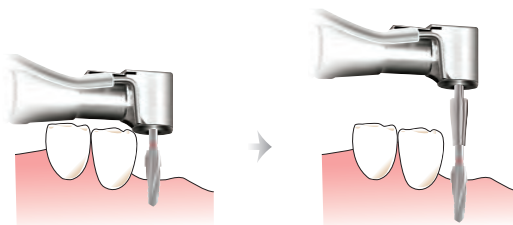

Mount Driver

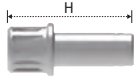
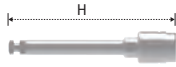

> Mount가 있는 Pre-Mount type의 Fixture 식립 시 Mount에 체결하여 사용

Height \ Type	Machine
20.5(Short)	* KMMD06S
26.3(Long)	KMMD06L
32.3(X-Long)	* KMMD12X

* 별도판매

Height \ Type	Ratchet
12(Short)	* KRMD12S
19(Long)	KRMD19L

* 별도판매

Hex Driver

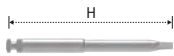

> Cover Screw, Abutment 체결 및 제거 등 여러가지 용도로 사용

Type	Machine	
Height \ Hex	Hex 0.9	Hex 1.2
22(Short)	* KMD09S	* KMD12S
28(Long)	* KMD09L	* KMD12L

* 별도판매

Type	Ratchet	
Height \ Hex	Hex 0.9	Hex 1.2
12(X-Short)	-	* KHD1212
17(Short)	* KHD0915	* KHD1215
23(Long)	* KHD0921	KHD1221
29(X-Long)	* KHD0927	KHD1227

* 별도판매

Fixture Driver

Sub.

Int.

Ext.

Sub.

Int.

Ext.

> Mount가 없는 No-Mount type의 Fixture 식립 시 Fixture에 직접 체결하여 사용

Type	Machine			
Length \ System	Sub.	Int.	Ext.(Hex 2.7)	Ext.(Hex 3.4)
28.1 / 26.3 / 26.4 (Short)	2KMMS01S	KMMI01S	KMME01S	KMME02S
33.3 / 30.5 / 31.4 (Long)	2KMMS01L	KMMI01L	* KMME01L	
40.3 / 35.5 / 36.4 (X-Long)	* 2KMMS01X	* KMMI01X	* KMME01X	

* 별도판매

Type	Ratchet			
Length \ System	Sub.	Int.	Ext.(Hex 2.7)	Ext.(Hex 3.4)
20.7 / 19.5 / 19.9 (Short)	* 2KHDS01S	KHDI01S	* KHDE01S	
25.7 / 24.5 / 24.9 (Long)	2KHDS01L	KHDI01L	KHDE01L	KHDE02L
30.7 / 29.5 / 29.9 (X-Long)	2KHDS01X	* KHDI01X	* KHDE01X	

* 별도판매

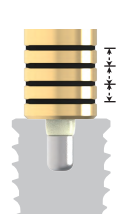
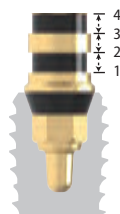

Torque Wrench



- > Fixture를 식립 할 때와 Fixture에 보철 부속을 연결할 때 수동으로 회전력을 제어
- > 탄성 손잡이를 이용하여 10 / 25 / 30 / 35 Ncm으로 회전력을 제어할 수 있으며, 단단한 일자 손잡이를 잡고 돌리면 최대 120 Ncm

Code	KTW001
------	--------



Depth Gauge



- > Drilling된 깊이를 측정, 반대편에 있는 5mm폭의 편평한 면이 인접한 Fixture의 최소 간격을 유지하도록 함

Code	KDG001
------	--------



- > Depth Gauge의 한 쪽은 Drilling 깊이를 측정하며, 다른 한 쪽은 Fixture 상단 부터 치은의 높이 측정

Code	KDG004	※ Submerged(Sub.) 전용
------	--------	----------------------

Fixture Path Gauge

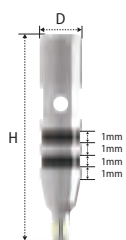

Sub. Regular

- > Implant 식립 후 Path확인 및 치은 높이 측정
- > Implant Connection에 따라 INNO Sub. Implant에 사용

Type	Sub. Regular
Diameter	Ø3.5
Height	17

* KFPG01R

* 별도판매



- * 제품 상단의 Marking으로 Connection 구분
- R - INNO Sub. Regular
- N - INNO Sub. Narrow

02 Drilling Sequence

E.g. 12mm Fixture

> Ø2.2 Initial Drill과 Final Drill를 이용한 간단한 Drill sequence (Ø3.5 / 4.0 / 4.5 fixture)

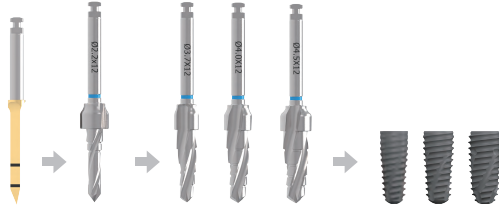

> Length Marking



Actual length of the Drill: Fixture + 1mm

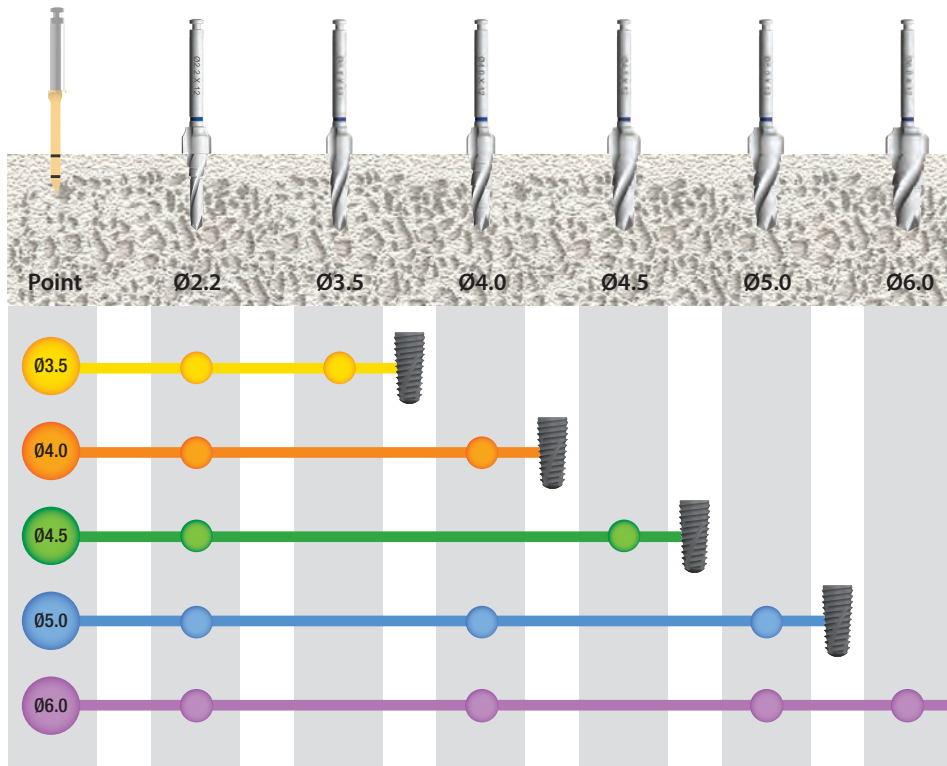

> Ø5.0 fixture: a series of the Point Drill, Initial Drill, Ø4.0 Final Drill, and Ø5.0 Final Drill.

> Ø6.0 fixture: a series of the Point Drill, Initial Drill, Ø4.0 Final Drill, Ø5.0 Final Drill, and Ø6.0 Final Drill.

Soft Bone (D4)

1단계 작은 직경의 Final Drill → Fixture식립

Hard Bone(D1, D2)

Final Drill → Countersink → Fixture식립

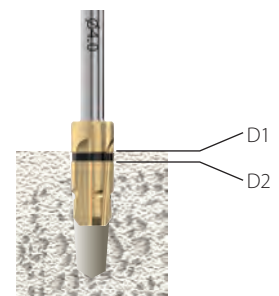

※ 경사진 치조능선에서의 Drill법

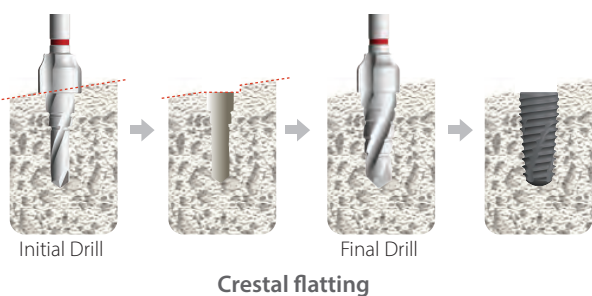

> Initial Drill 및 Final Drill의 Crestal Cutter로 평탄화
> Implant 길이보다 한 치수 더 긴 Drill 사용

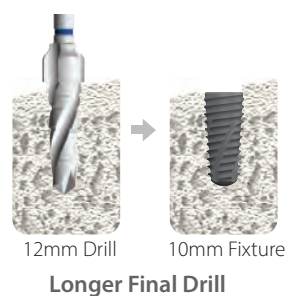

※ 넓은 발치와에서의 Drill법

> 해면골에 식립
> Fixture 직경보다 한 치수 좁은 Drill 사용

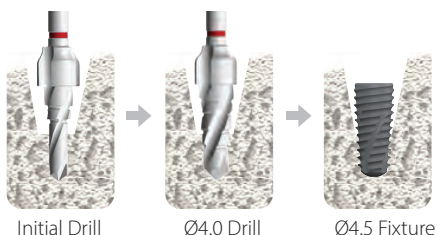

※ 식립 토크 조정법

> 0.5mm 더 깊게 식립하여 최대 토크를 올릴 수 있음



Level	Fixture placement level					
	Crestal Level			0.5mm Deeper Level		
Density	D1	D2	D3	D1	D2	D3
Torque	34.1	29	15.5	44.4	38.4	19.1

> Drill 홈에서 Pumping Action으로 골 분쇄물 제거 효과
> 치밀골에서는 식립 토크를 낮춤

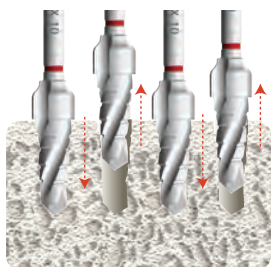

Density	Pumping action while final drilling		
	D1	D2	D3
Non-Debridement	34.1	29	19.6
Debridement	30	25	15.5

※ Bone Quality 4에서의 토크 조정

> Pumping Action을 하지 않고 한 번에 최종 깊이까지 Drilling
> 0.5mm 더 깊게 식립
> 식립 Implant보다 한 단계 낮은 직경의 Final Drill 사용

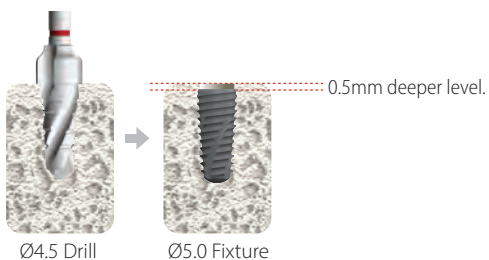

Level	Fixture placement level			
	Crestal level		0.5mm Deeper Level	
Debridement	with	without	with	without
Ø4.5 Fixture	4.4	10.2	-	12.9
Ø5.0 Fixture	11.6	19.9	14.1	24.5

INNO SUB. SHORT SURGICAL KIT [KSI001]



> INNO Submerged Short Implant System(Sub.)



Point Drill

Step Drill

Point Drill KPD015	Ø2.0 Step Drill KSSD2004	Ø4.0 Step Drill KSSD4004	Ø4.5 Step Drill KSSD4504	Ø5.0 Step Drill KSSD5004	Ø5.5 Step Drill KSSD5504	Ø6.0 Step Drill KSSD6004

Stopper

Countersink

4mm Drill Stopper SIDS04	5.5mm Drill Stopper SIDS05	7mm Drill Stopper SIDS07	Ø4.0 Countersink 4KCS40S	Ø4.5 Countersink 4KCS45S	Ø5.0 Countersink 4KCS50S	Ø5.5 Countersink 4KCS55S	Ø6.0 Countersink 4KCS60S

Mount Driver

Hex Driver

M. Mount Driver L KMMD06L	R. Mount Driver L KRMD19L	1.2 Hex Driver L KHD1221	Torque Wrench KTW001

Length Marking & Stopper

Actual length of drill: Fixture + 0.5mm.

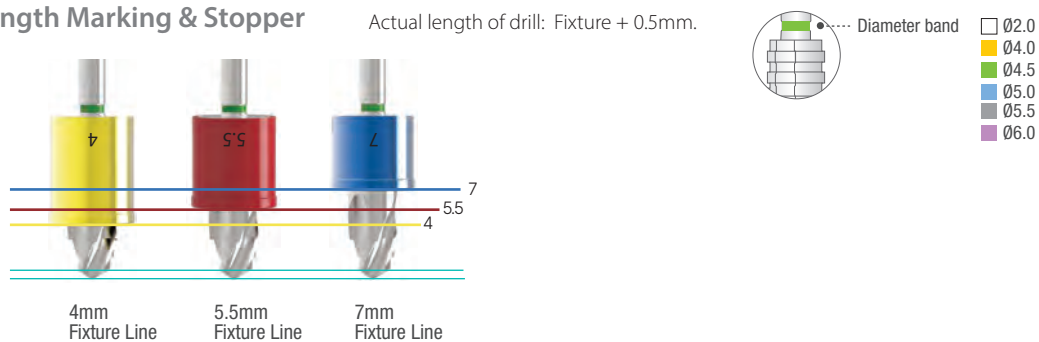

Drilling Sequence

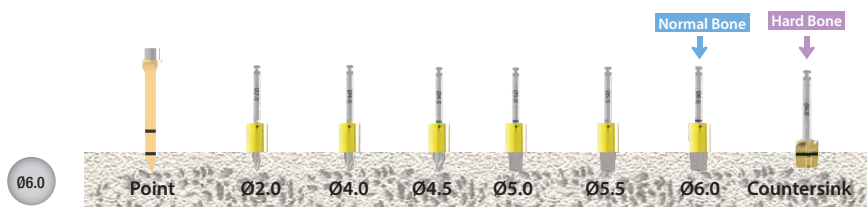
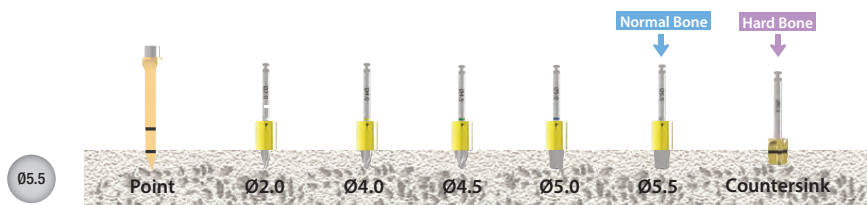
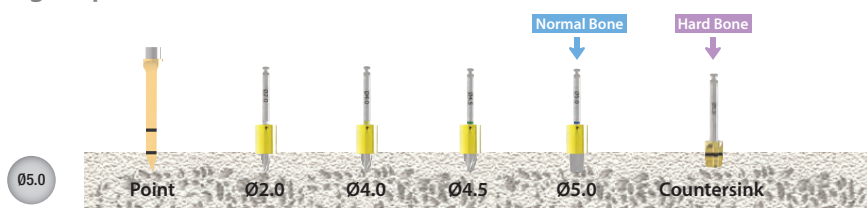

INNO SUB. NARROW SURGICAL KIT [KNA001]



> INNO Submerged Narrow Implant System(Sub-N.)

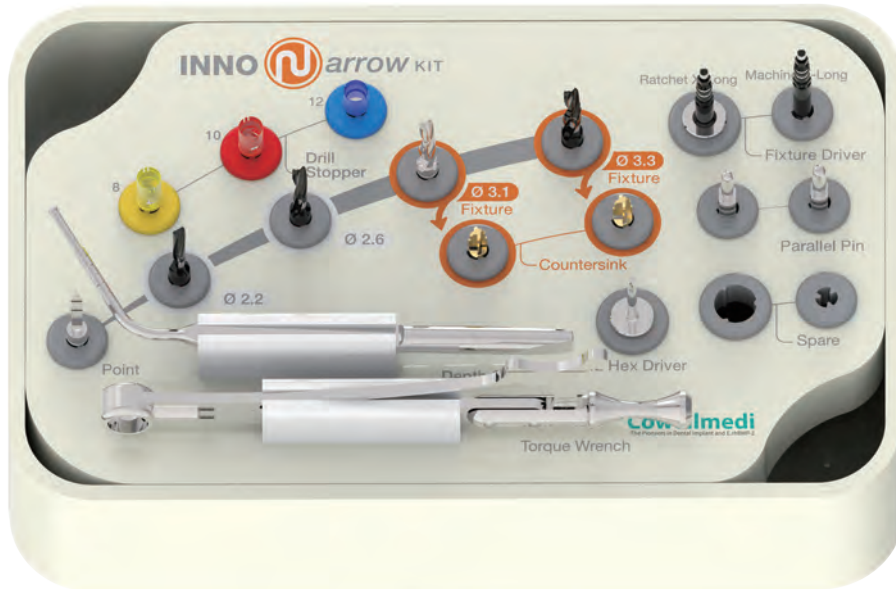

Point Drill



Twist Drill

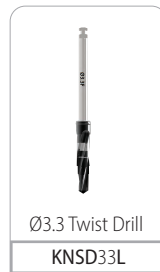
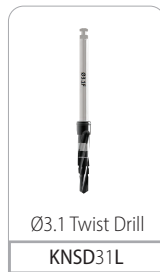
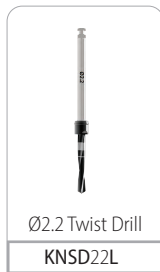

Stopper

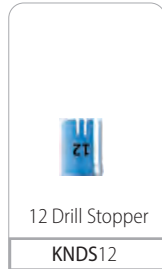

Countersink

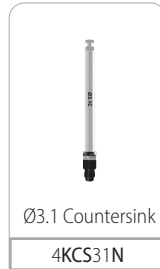

Fixture Driver



Parallel Pin



Hex Driver



Depth Gauge



Torque Wrench

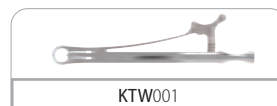

Fixture Driver

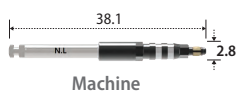

Machine

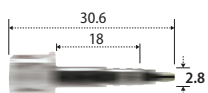

Ratchet

Type	Machine	Ratchet
	KMMS01XN	KHDS01XN

- > No-Mount type의 Fixture 식립 시 Fixture에 직접 체결하여 사용
- > Pre-Mount의 경우 Mount Driver를 사용하여 식립 (*별도판매)

Parallel Pin



Code	KPP003
------	--------



Fixture Path Guage

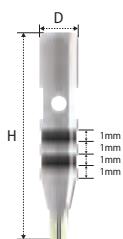

Sub. Narrow

- > Implant 식립 후 Path확인 및 치은 높이 측정
- > Implant Connection에 따라 INNO Sub. Narrow Implant에 사용

Type	Sub. Narrow
Diameter	Ø3.1
Height	17
	* KFPG01N

* 별도판매



- * 제품 상단의 Marking으로 Connection 구분
- R - INNO Sub. Regular
- N - INNO Sub. Narrow

Drilling Sequence

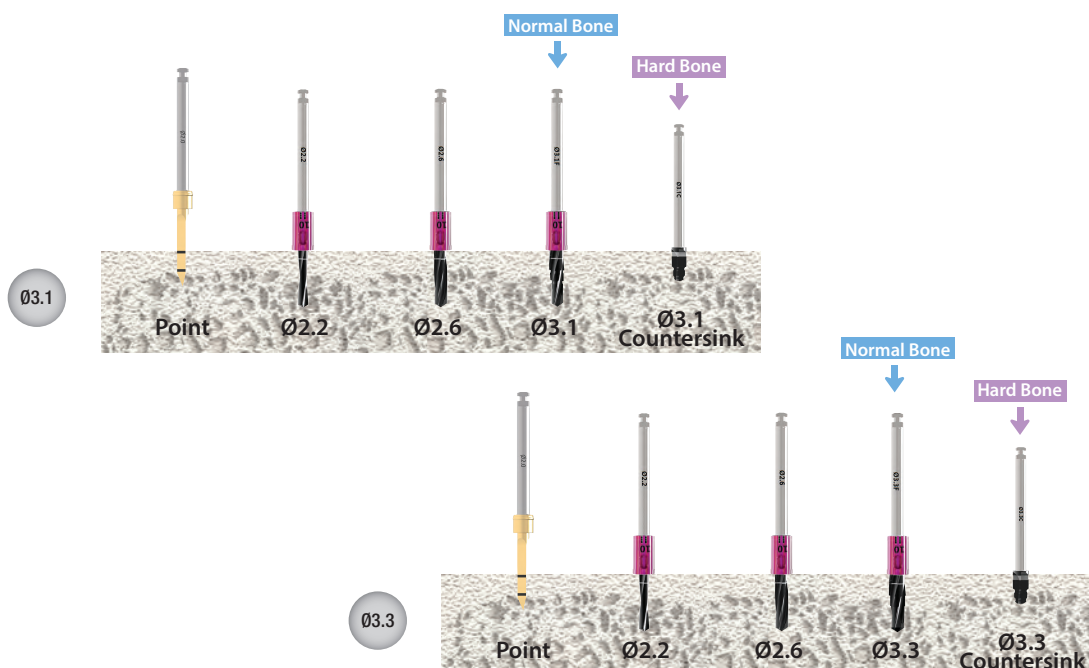

MINI PLUS SURGICAL KIT [KMA003]

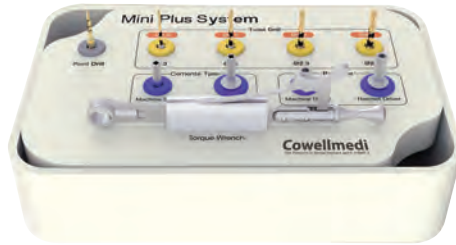

Point Drill

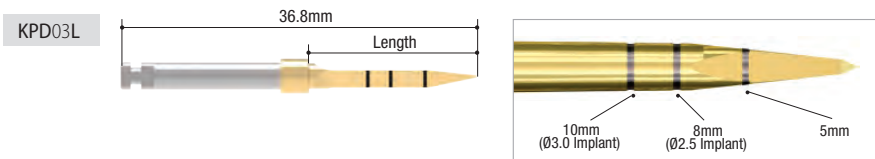

> Cortical Bone에 천공 위치를 선정하여 초기 Drilling을 용이

Ø1.3 Twist Drill

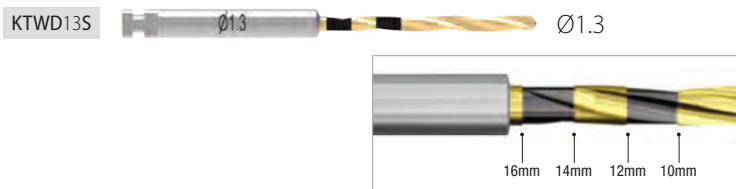

Ø1.8 Twist Drill

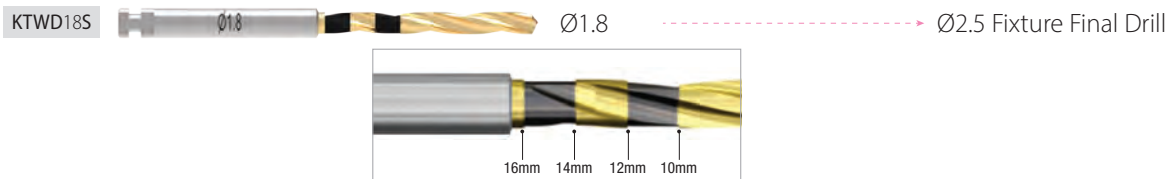

Ø2.3 / Ø2.6 Twist Drill

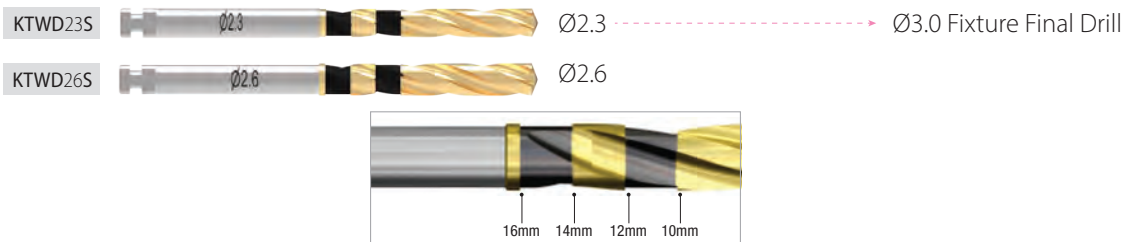

Driver

Cement Type

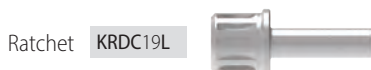

Ball Type



Tissue Punch *Extra product

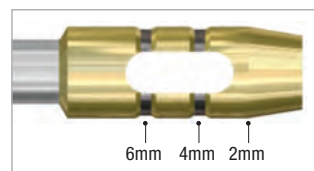

- > Flapless로 시술 시 연조직 천공
- > Fixture의 직경보다 0.3mm 큰 직경

Multi Gauge *Extra product

> 드릴 깊이와 경로의 정확한 측정을 위해 사용

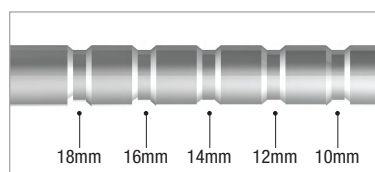
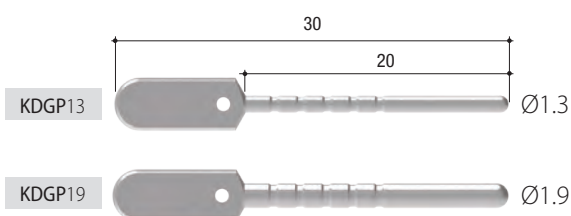

Drilling Sequence

Ø2.5

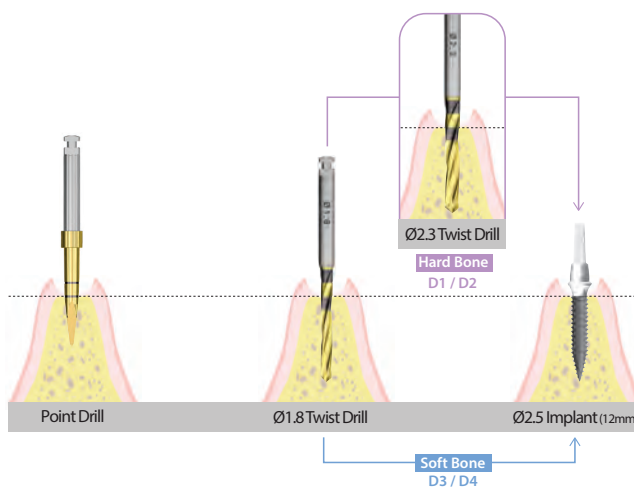

Ø3.0

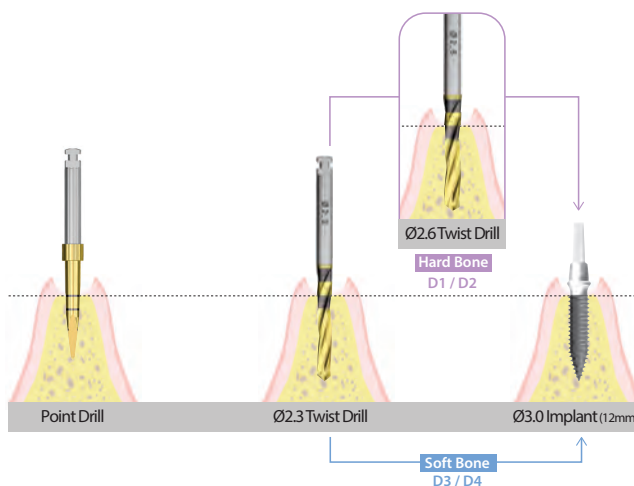

※ 골질 D4 Bone에서는 Drilling 깊이를 조절하여 Fixture가 Self-tapping하면서 식립 될 수 있도록 함

INNO PROSTHETIC PLANNING KIT [KIPP001]

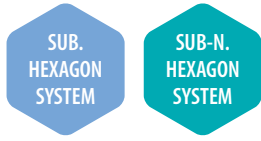

- > INNO Submerged, Submerged Short(Sub.) 및 Submerged Narrow Implant System(Sub-N.)
- > 최종 Abutment의 Size 설정을 위한 Try-in kit



Straight

- > Straight type abutment의 최종 Abutment의 직경, 길이 및 Cuff등의 치수 측정용
Cemented | Absolute | Straight Abutment



- **Breakaway Stopper**
실크를 연결하여 구강 내 탈락을 방지
 - **Cuff Marking**
2 또는 4mm로 Cuff(Gingival height) 표기
 - **Cuff Height**
Cuff에 해당하는 부위로 층례 따라 2 또는 4mm의 Abutment Gauge 선택
 - **Diameter**
직경에 따라 각기 다른 Coloring
- Ø3.8 ● Ø4.5 ● Ø5.5 ● Ø6.5
Green Yellow Purple Blue

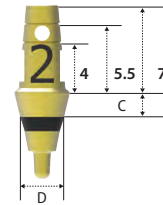

Abutment Gauge



Type	Regular		
Diameter	Ø4.5	Ø5.5	Ø6.5
<i>Cuff</i> / <i>Length</i>	7		
2	P2SCH4527	P2SCH5527	P2SCH6527
4	P2SCH4547	P2SCH5547	P2SCH6547

- > 포장단위 : 1 Abutment Gauge
- > INNO Submerged / Submerged Short(Sub.)에 사용
- > Straight type abutment(Ø4.5/5.5/6.5)의 Size 측정

Abutment Gauge-N



Type	Narrow	
Diameter	Ø3.8	Ø4.5
<i>Cuff</i> / <i>Length</i>	7	
2	PSCH3827N	PSCH4527N
4	PSCH3847N	PSCH4547N

- > 포장단위 : 1 Abutment Gauge-N
- > INNO Submerged Narrow(Sub-N.)에 사용
- > Straight type abutment(Ø3.8/4.5)의 Size 측정

Angulated

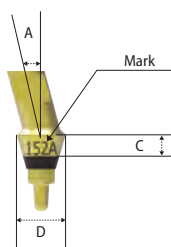

> Angulated Type의 직경, 커프 및 길이를 예측하여 올바른 크기의 Abutment와 Crown을 선택하는 데에 도움
Angulated I Beauty-up Abutment

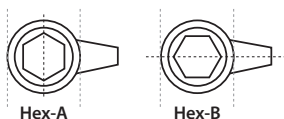

Abutment Gauge



Type	Hex-A	
Diameter(Angle)	Ø4.5(15°)	Ø4.5(25°)
Cuff / Length	8	
2	P2SAH45152A	P2SAH45252A
4	P2SAH45154A	P2SAH45254A

Type	Hex-B	
Diameter(Angle)	Ø4.5(15°)	Ø4.5(25°)
Cuff / Length	8	
2	P2SAH45152B	P2SAH45252B
4	P2SAH45154B	P2SAH45254B

> 포장단위 : 1 Abutment Gauge
> INNO Submerged / Submerged Short(Sub.)에 사용
> Angulated type abutment(15°/25°)의 Size 측정
> Fixture 식립 방향에 따라 Hex-A 또는 Hex-B 선택

Abutment Gauge-N



Type	Hex-A			
Diameter(Angle)	Ø3.8(15°)	Ø3.8(25°)	Ø4.5(15°)	Ø4.5(25°)
Cuff / Length	8			
2	PSAH38152NA	PSAH38252NA	PSAH45152NA	PSAH45252NA
4	PSAH38154NA	PSAH38254NA	PSAH45154NA	PSAH45254NA

Type	Hex-B			
Diameter(Angle)	Ø3.8(15°)	Ø3.8(25°)	Ø4.5(15°)	Ø4.5(25°)
Cuff / Length	8			
2	PSAH38152NB	PSAH38252NB	PSAH45152NB	PSAH45252NB
4	PSAH38154NB	PSAH38254NB	PSAH45154NB	PSAH45254NB

> 포장단위 : 1 Abutment Gauge-N
> INNO Submerged Narrow(Sub-N.)에 사용
> Angulated type abutment(15°/25°)의 Size 측정
> Fixture 식립 방향에 따라 Hex-A 또는 Hex-B 선택

INNO PROSTHETIC INSTRUMENT KIT [KPA004]



> INNO Implant System의 모든 type(Sub, Sub-N. Int. Ext.)의 보철류 등에 사용되는 All-in-one instrument kit



1.2 Hex Driver

 12mm KHD1212	 17mm KHD1215	 23mm KHD1221	 29mm KHD1227	 39mm KHD1239	 Short KMD12S	 Long KMD12L
Ratchet					Machine	

Angulated Screw Driver

 Short KRBUD15

 Long KRBUD20

Multi Driver and Holder

 Ratchet KRMSD15L

 Machine KMMSD21L

 Multi S KMHS01

 Multi A KMHA01

Multi S Driver

Holder

Straight/Solid/Shoulder Driver

 Short KRR12S

 Long KRR19L

 Short KRW12S

 Long KRW19L

Lock Driver

 Short KRLRD18

 Long KRLRD28

Regular

Wide

Absolute Driver

 Short KRAD4512S

 Long KRAD4519L

 Short KRAD5512S

 Long KRAD5519L

 Short KRAD6512S

 Long KRAD6519L

Ø4.5

Ø5

Ø6.5

Sonator

 S Ratchet Driver SONRD19L

 I&R Driver SONIR002

Ball

 Driver KRB19L

 I&R Driver KBIR01

Torque Wrench

 KTW001

Surgical tool management

수술 도구 관리의 일반 원칙

ㄱ. 모든 수술 도구는 멸균 상태가 아닌 상태로 제공되므로 사용 전에 세척 및 멸균해야 합니다.

*** 주의 : 잘못된 세척 및 멸균 공정으로 인해 공구가 부식되고 손상되며, 직접 사용할 경우 2차 감염의 원인이 될 수 있습니다.**

ㄴ. 드릴 사용 권장 횟수는 골격 상태를 기준으로 20~30회이며, 블레이드가 손상되거나 변형된 경우 교체해야 합니다.

*** 주의 : 손상된 드릴을 사용할 경우 열 nekrosis가 발생할 수 있습니다.**

ㄷ. 수술 도구를 관리할 때는 감염을 막기 위해 마스크와 장갑을 착용해야 합니다.

세척 매뉴얼

(주)코웰메디는 거품이 적으면서 계면활성제를 함유하고 오염물질을 쉽게 행구어 낼 수 있는 사용자 친화성 제품인 효소 세척제 사용을 권장합니다.

효소세척제 선택 시 입증된 효능 (FDA승인, CE마크)을 가진 세척제만 사용을 해야 합니다.

전 세계에 다양한 세척제 및 소독제가 존재하므로 (주)코웰메디에서는 특정 브랜드를 권장하지 않습니다.

(주)코웰메디의 시술기구 세척매뉴얼에 사용된 세척제는 유효성이 검증된 세척제로 다음과 같습니다.

CIDEZYME (Enzymatic Detergent Solution) : J&J

모든 세척제는 제조업체가 권장하는 세제 희석 비율 및 세척온도로 준비를 해야 세척제의 최적 성능의 효과를 낼 수 있습니다.

***참고** 의료시설에서 처리하는 수동 세척은 세척장비나 인적요소에 의해 세척변수가 발생할 수 있으므로 유효성이 검증된 적절한 절차나 문서가 마련되어 있어야 합니다.

▶ 시술기구 세척방법

(주)코웰메디에서 권장하는 시술기구의 세척 지침은 유효성이 검증된 세척방법으로 다음과 같습니다.

1. 충분한 양의 에틸알코올 (70%)에 담가 10분간 초음파 세척을 실시합니다.
2. 에틸알코올을 세척 후에도 남아 있을 수 있는 혈흔 및 이물질을 제거하기 위하여 증류수나 흐르는 물에서 세척하기 어려운 부위는 Syringe 또는 Pipecleaner (부드러운 세척용 솔)를 이용하여 세척을 합니다.
3. 효소 세척제를 제조업체가 권장하는 비율로 수돗물 혹은 증류수로 희석하여 제품을 완전히 잠기도록 충분한 분량의 물에 담근 후 35~40Khz에서 15분간 초음파 세척을 실시합니다.
4. 제품 세척을 위해 사용한 세척제 및 이물질을 제거하기 위해 흐르는 증류수로 3분 동안 행구어 줍니다.
5. 건조된 천이나 온풍기로 수분을 완전히 제거 후 시술기구를 트레이에 조립한 상태 또는 단독으로 수술포로 감싸 사용자 멸균 방법으로 멸균을 실시합니다.

▶ 주의사항

1. 시술기구 세척 시 시술기구에 해당하는 부품의 분실에 주의해야 합니다.
2. 시술기구를 다룰 시에는 날카로운 부위에 다치지 않도록 주의해야 합니다.
3. 부드러운 브러시를 사용하여 오염물을 완전히 제거해야 합니다.
와이어 브러시 또는 스테인레스 재질 브러시를 사용하지 마십시오.
4. 기기의 부식이나 물때를 방지하기 위해 건조기나 여과된 압축 공기로 완전히 건조합니다.
5. 기기를 제대로 행구지 않거나 잔여물이 남아 있거나 제대로 건조하지 않으면 멸균 과정에 변색되거나 부식될 수 있으므로 전체 과정을 다시 거쳐야 합니다.

6. 혈액 얼룩이나 뼈 잔여물과 같은 이물질이 완전히 제거되지 않으면 부식이 시작될 수 있습니다. 사용 직후 세척해야 하며 세척 시 이물질을 완전히 제거해야 합니다.

▶ 초음파 세척기 사용시 주의사항

1. 오염제거가 필요한 기구를 초음파 세척기에 넣기 전에 기구 표면의 혈액이나 눈에 보이는 큰 오염물질을 미리 제거합니다.
2. 해당 장비의 세척용 침전 용액은 제조사에서 권고하는 것을 사용하며 용액의 온도는 MSDS 15°C - 30°C 까지를 기준으로 합니다.
3. 초음파 세척기에 사용하는 세제는 약알칼리성이 적절합니다.
4. 멸균이 필요한 기구는 초음파 세척기로 세척 후 가능한 빨리 멸균하고 공기 중에서 건조되지 않도록 물기를 닦아냅니다.

멸균 소독 매뉴얼

㉔코웰메디에서 권장하는 시술기구의 멸균 지침은 유효성이 검증된 고압증기멸균 방법으로 10⁻⁶ 무균성 보증 수준(S.A.L)을 보장합니다.

의료시설에서 사용하는 소독기는 제조업체의 권장사항을 준수하여야 하며 여러 기기를 멸균처리할 시 제조업체에서 권장하는 소독기 사양을 초과하지 않아야 합니다.

시술 기구 세트는 증기 침투가 용이하면서 제품 표면에 직접 접촉할 수 있도록 만들어진 트레이 및 별도의 케이스에 넣어 멸균 준비를 하여야 합니다.

***참고** 의료시설에서 처리하는 멸균은 멸균 장비나 인적요소에 의해 멸균변수가 발생할 수 있으므로 유효성이 검증된 적절한 절차나 문서가 마련되어 있어야 합니다.

▶ 시술기구 멸균방법

(주)코웰메디에서 권장하는 시술기구의 멸균 매뉴얼은 유효성이 검증된 멸균방법으로 다음과 같습니다.

멸균방법 및 조건은 습열멸균방법 (고압증기멸균)으로 시술기구를 (주)코웰메디 시술기구 트레이에 넣은 후 수술보에 감싸 121°C에서 40분, 건조시간 30분을 권장합니다.

▶ 주의사항

1. 제품을 사용하기 전 제품에 이물질 및 녹 등 이상이 없는지 확인이 필요합니다.
2. 본 제품은 비멸균 상태로 공급되므로 사용 전 반드시 멸균소독을 실시 해야 합니다.
3. 본 제품은 사용 후 즉시 제조사의 세척방법에 따라 세척을 권장하며 세척 후에는 건조하고 깨끗한 장소에 보관하며 사용 전 반드시 멸균 소독을 실시 하여야 합니다.

보관 관리

- ㄱ. 사용후에는 반드시 세척하여 실온의 건조한 곳에서 보관합니다.
- ㄴ. 보관된 기구는 사용전 세척하고, 멸균하여 사용합니다.

Lodestar Plus Kit [KLSP001]

- > 다양한 임상에 적용 가능한 Total Guided Surgery Solution
- > INNO Submerged 및 Submerged Narrow Implant System 전용

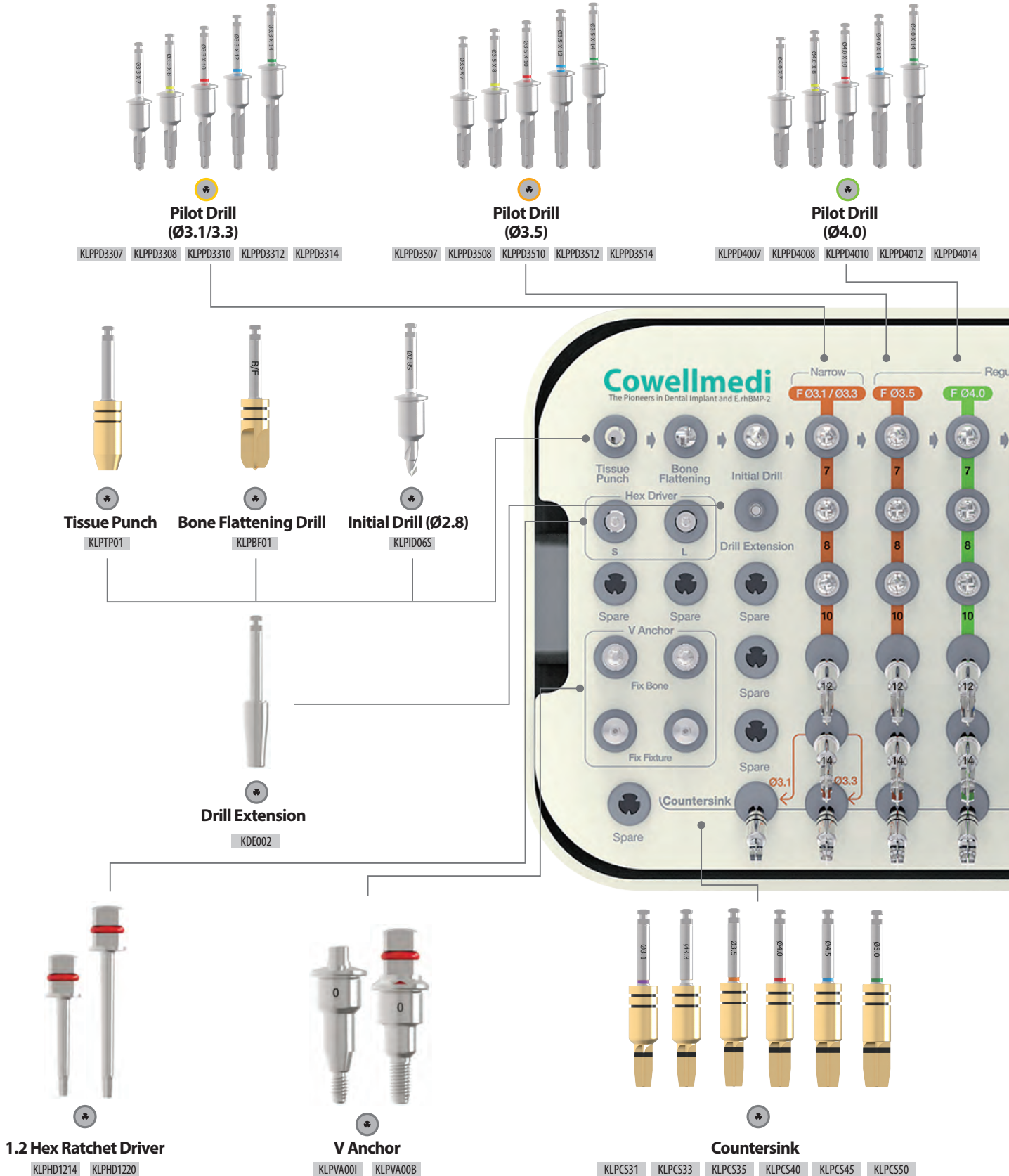



Pilot Drill (Ø4.5)

KLPPD4508 KLPPD4510 KLPPD4512 KLPPD4514



Pilot Drill (Ø5.0)

KLPPD5007 KLPPD5008 KLPPD5010 KLPPD5012 KLPPD5014



Implant Adapter

KLPF01R KLPF02R KLPF01N KLPF02N



Lodestar Plus



Fixture Driver

KLFPD21



Torque Wrench

KTW001LP



Adapter Extension

KLPRE08S KLPRE12L KLPMEO8S KLPMEL2L



Abutment Profiler

KLPA10 KLPA12 KLPA14

Workflow

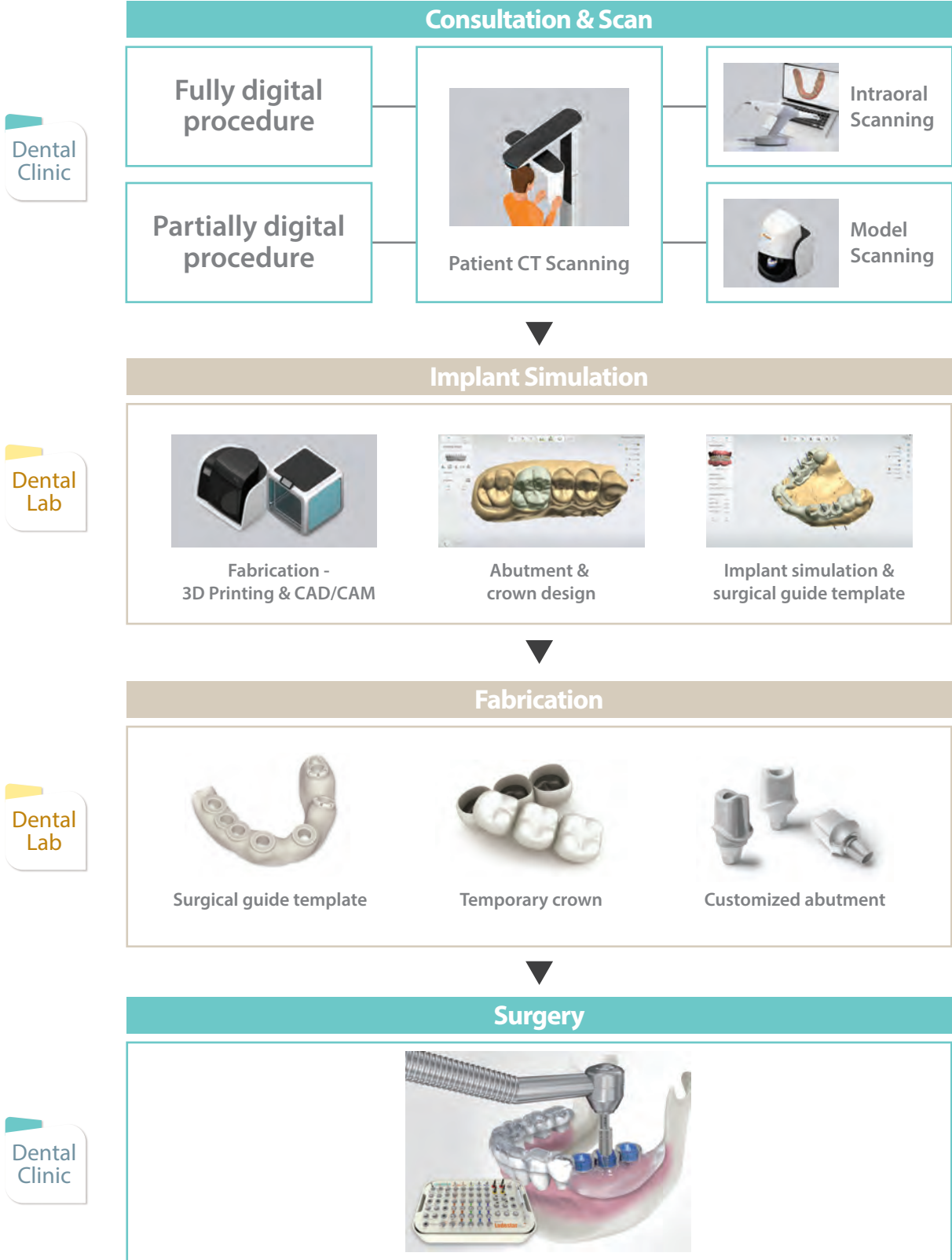

수술 전 준비사항



Surgical guide 소독

소독은 수술전에 해야 하며 Surgical guide를 알코올과 클로르헥시딘(Chlorhexidine)용액을 9: 1 로 혼합한 용액이나 CidexOPA, Betadine등의 소독액에 20분이상 담구어 소독한 후 생리 식염수로 헹구어서 환자 구강에 장착



Surgical guide 장착 체크

- 제작된 Surgical guide의 Window를 통하여 Surgical guide 내면과 치아 외면이 정확하게 장착되었는지 확인
- 스캔데이터가 불충분하여 Guide가 구강에 정확하게 안착이 되지않을 경우 내면을 삭제하여 조정
- 수술 전 Guide를 장착하여 CT촬영을 하면 식립 Path나 정밀성 확인가능
(시술 후에도 Guide를 장착 후 CT 촬영하면 식립 Path를 확인 가능)



Implant 확인

Surgical report에 표기된 Implant가 있는지 확인 필요



Protocol 확인

Surgical report 확인 및 Surgical protocol을 최종적으로 확인

Comprehension and Usage of Offset

- > Sleeve 상단에서 Fixture platform 사이의 거리로 기본 길이는 9mm
- > 잇몸이 두꺼운 환자나 Bone이 좋지 않아 Fixture를 더 깊이 식립 하여야 할 경우 Sleeve를 상단으로 2mm, 4mm 높게 사용
- > Offset을 올릴수록 정확도가 떨어지기에 가능한 9mm로 사용 권장

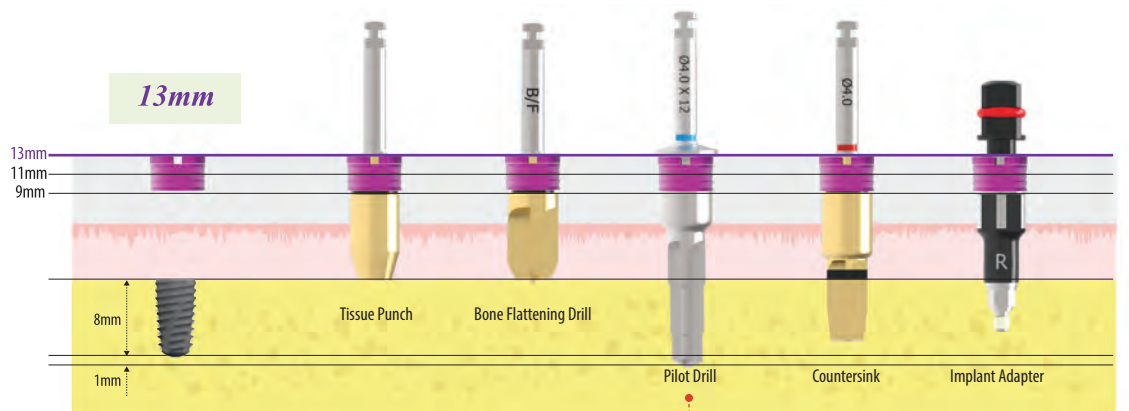
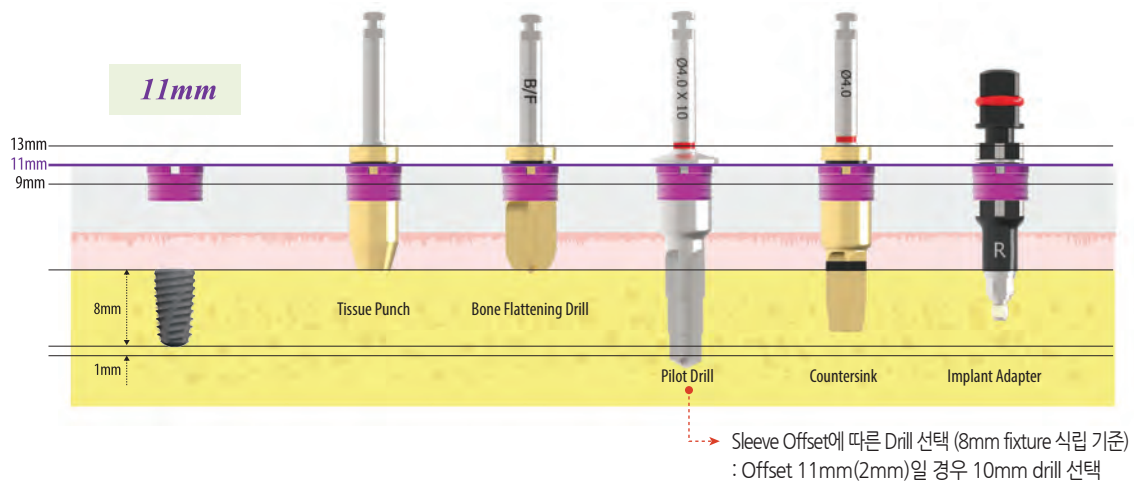
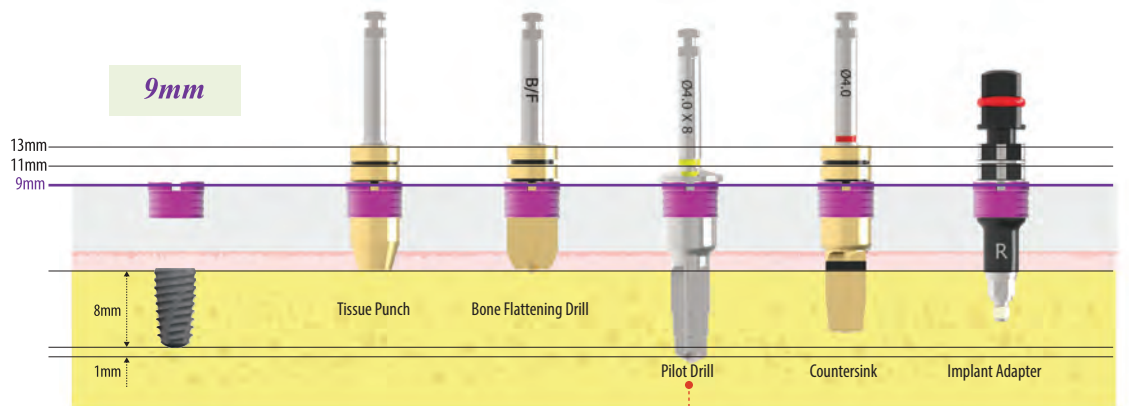

* Caution

실 Drilling 깊이는 표기된 깊이보다
1mm 더 깊으니 유의하여 사용.
Ex) 4.0 X 8mm Drill - Drilling depth : 9mm

Tissue Punch

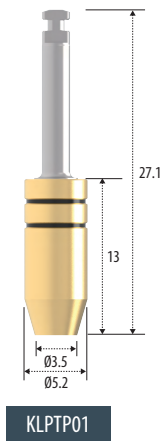

- > Soft tissue 제거 시 사용(시술 위치의 치은을 원형으로 절개)
- > 작은 직경의 Punch로 인하여 시술 후 지혈효과, 작은 시술흔적, 빠른 창상 치유의 효과 발생
- > Offset 적용 가능(9mm, 11mm, 13mm)
- > 무주수 50rpm

Double blade
 내부 고정날부가 잇몸을 분쇄 시켜 별도의 제거 작업이 없이 Suction으로 흡입하여 안정적으로 Gingiva 제거 가능

*** Caution** 수술 후 Tissue punch 내부에 분쇄된 잇몸등의 잔여물이 남을 시 녹 발생, 날 부 손상의 문제가 발생하므로 깨끗이 관리 필요(Explorer 및 Steam등으로 잔여물 제거)

Bone Flattening Drill



- > 시술 부위의 치조경 골면(Bone Level) 평탄하게 만들
- > Bone Level이 경사져 있을 경우 Drill이 미끄러져 계획대로 Drilling 되지 않을수 있음
- > Tissue Punch 사용 후 남아 있는 연조직을 제거
- > 중앙의 Point부가 다음 Drill의 Guide 역할을 하여 정확한 위치에 Drilling 가능
- > Offset 적용 가능(9mm, 11mm, 13mm)
- > 무주수 400rpm / 주수 800 rpm



Initial Drill

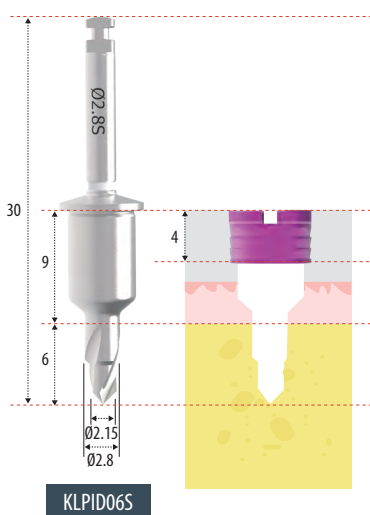

- > High Speed, 주수 1000rpm

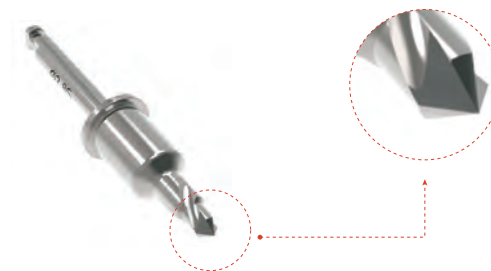

Point
 골표면에 홈을 만들어 다음에 사용하는 Drill의 축이 흔들리지 않도록 하며, 경사진 Bone Level에서도 미끄러짐 없이 Drill Position을 Guide

Ø3.1/Ø3.3 Fixture

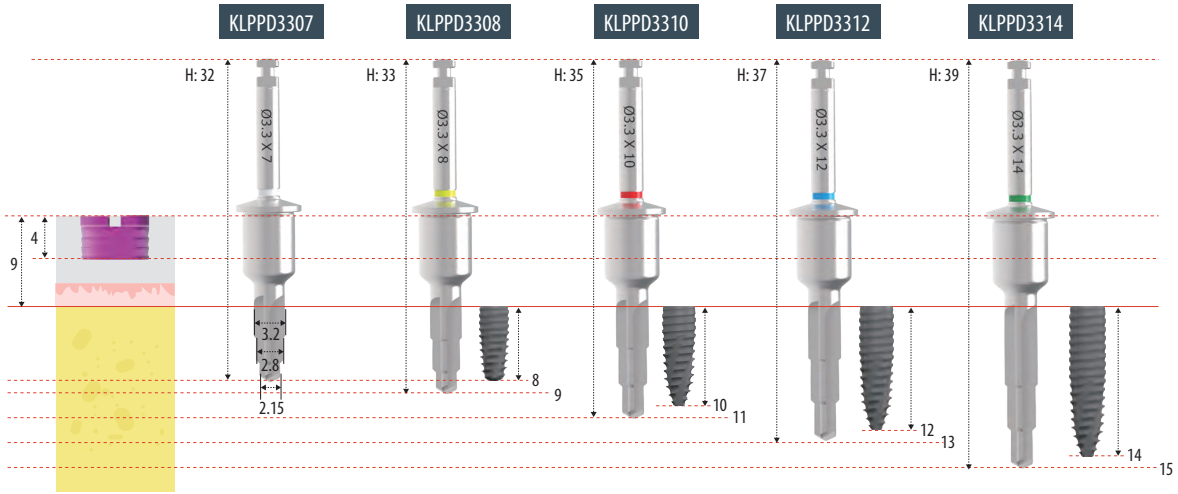

Ø3.5 Fixture

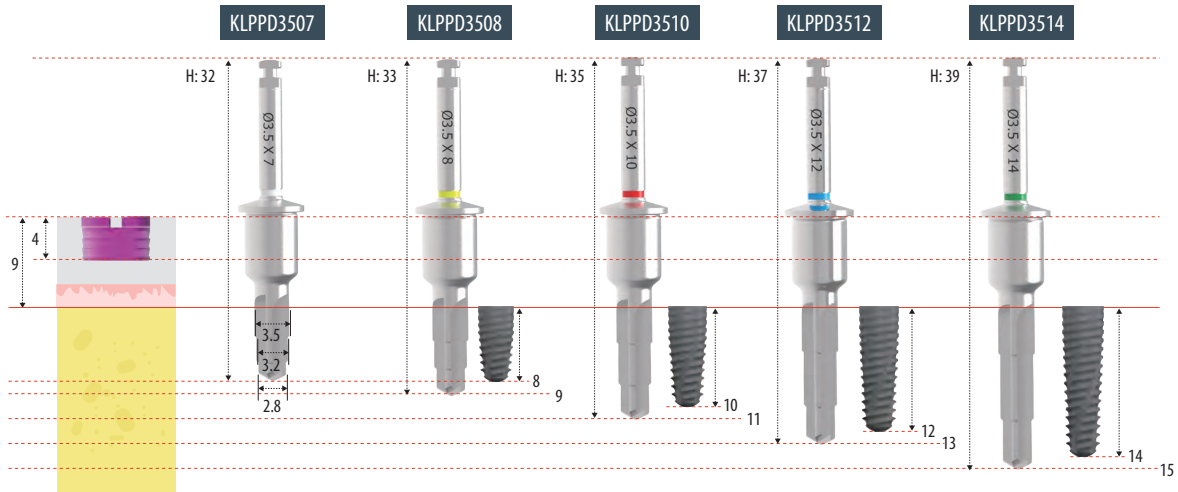

Ø4.0 Fixture

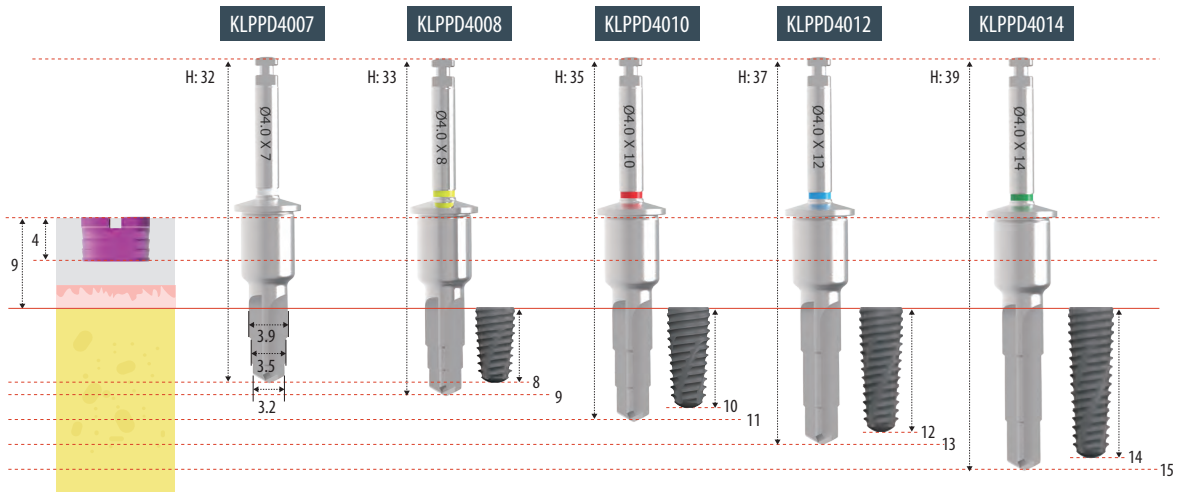

Ø4.5 Fixture

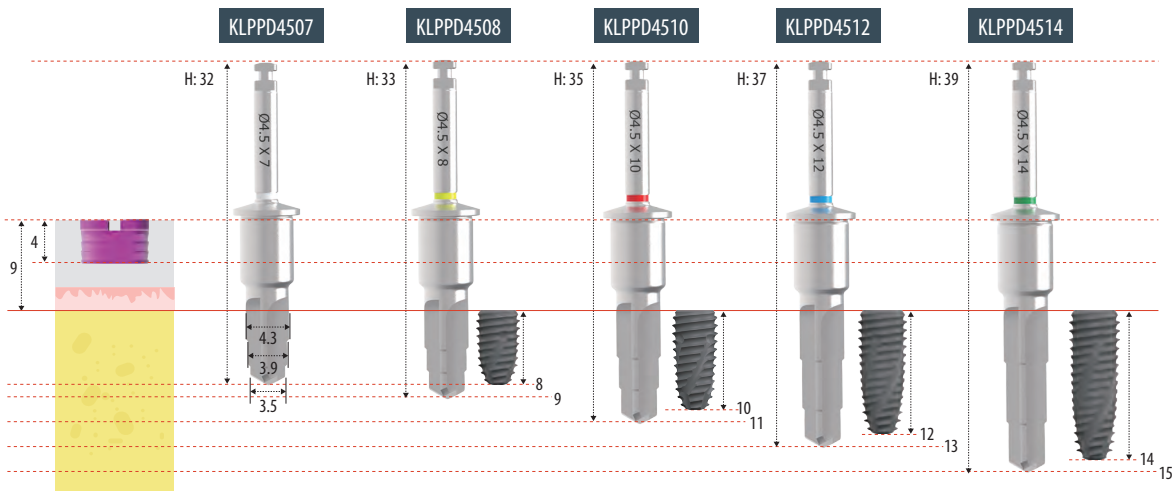

Ø5.0 Fixture

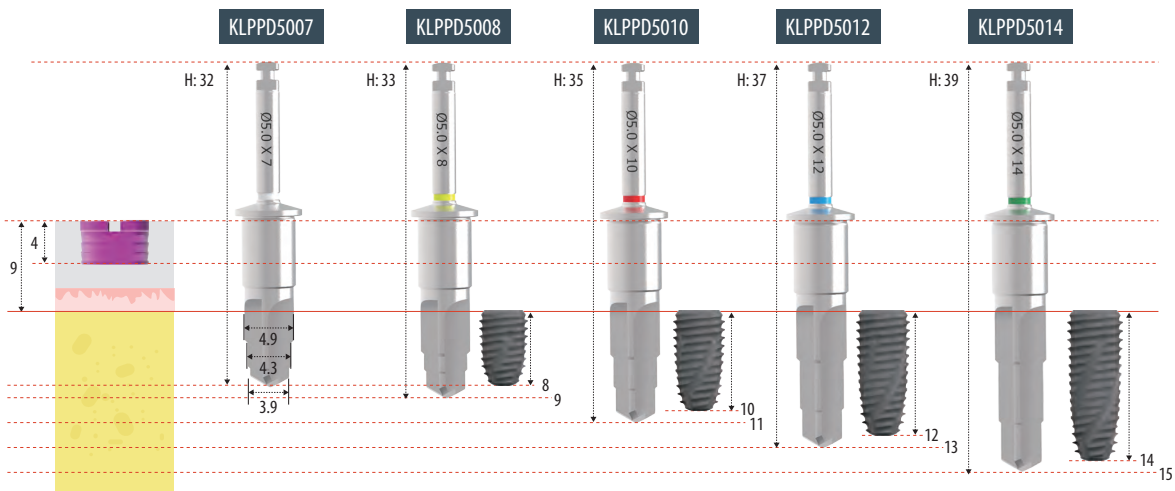

Countersink

- > D1/D2 Bone에서 Cortical bone을 넓혀 Fixture의 과도한 식립 토크 방지
- > Offset 적용 가능(9mm, 11mm, 13mm)
- > 무주수 50rpm

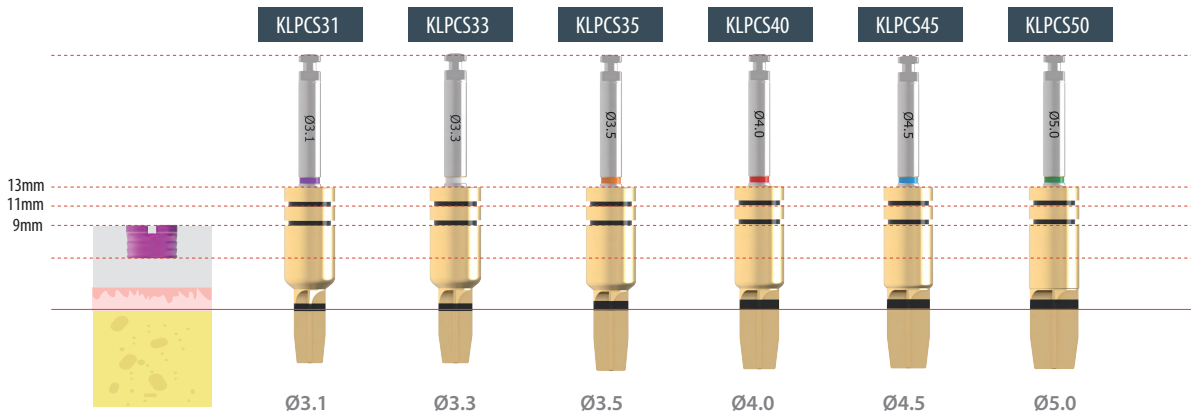

Adapter Extension

- > Implant Connector의 길이가 짧아 사용하기 어려울 경우 연결하여 Ratchet 또는 Machine으로 Fixture를 식립

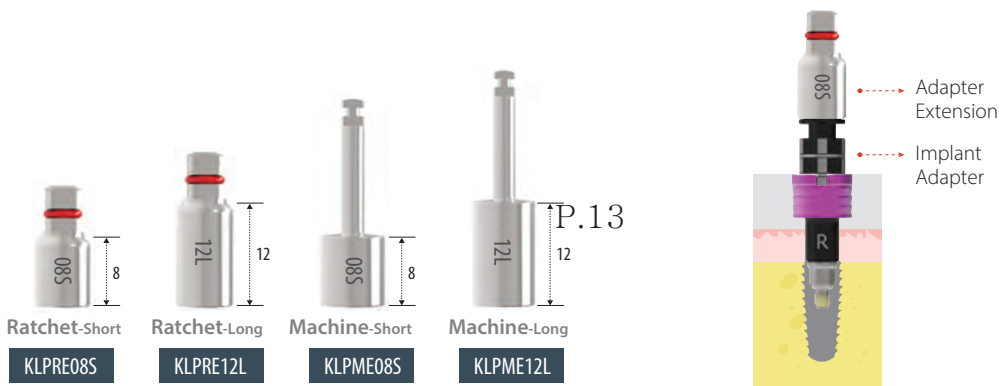

Implant Adapter

- > Fixture를 Sleeve까지 이동시켜 안정적으로 식립
- > Sleeve offset과 Implant Connector 레이저 마킹에 맞추어 깊이를 일치
- > Fixture 식립 시 Implant Connector의 방향과 Sleeve 홈의 방향성을 맞추면 Temporary Abutment의 Hex 방향과 일치
- > Fixture 식립 후 Implant Connector가 냉간 합착되어 제거가 안될 시 홈부에 Crown remover를 걸어서 제거

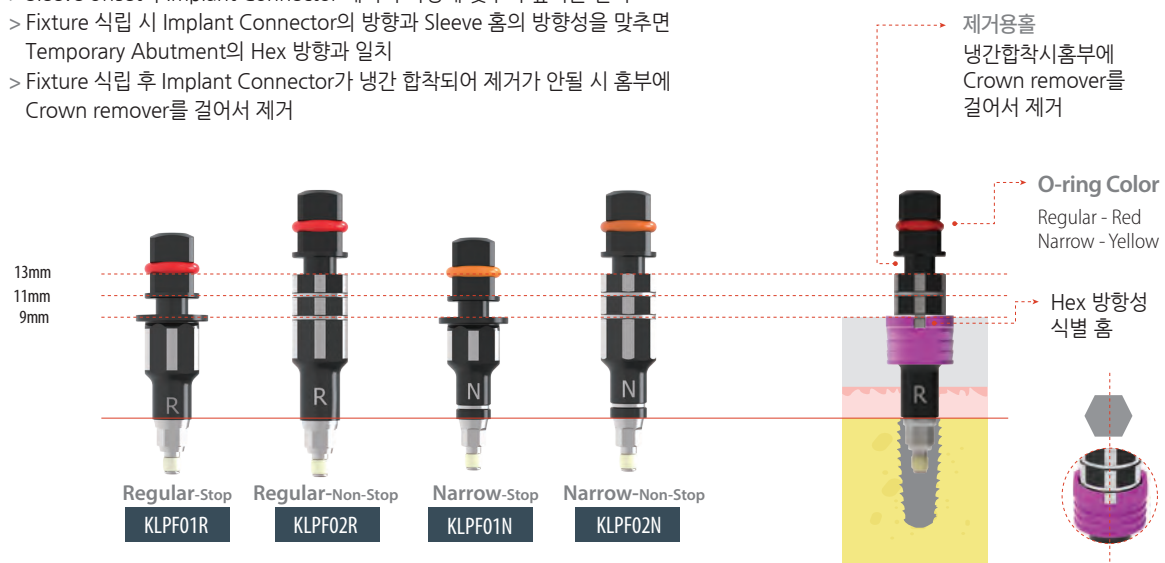

Fixture Driver - Molar

> 개구량이 작거나 대합치와의 간격이 너무 좁아 Implant Connector를 사용할 수 없을 경우 사용
> 4~5mm 식립 후 Implant Connector로 교체하여 완전히 식립



KLPFD21

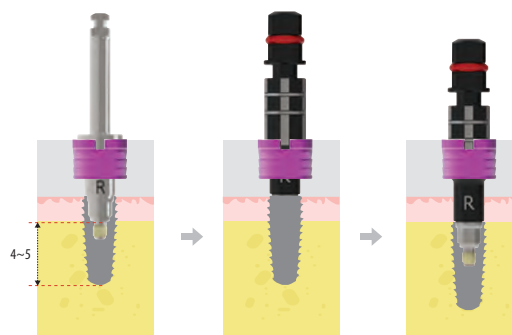

① Place 4~5mm. ② Change to the Implant Adapter. ③ Complete placement.

Abutment Profiler

> Abutment 체결 시 간섭이 되는 Fixture의 인접 치조골을 제거하고 Drill을 360° 회전시켜 잔존골 제거
> Cortical bone이 두꺼울 경우, Drilling rpm을 높이고 주수를 하면서 사용(100rpm 이내)

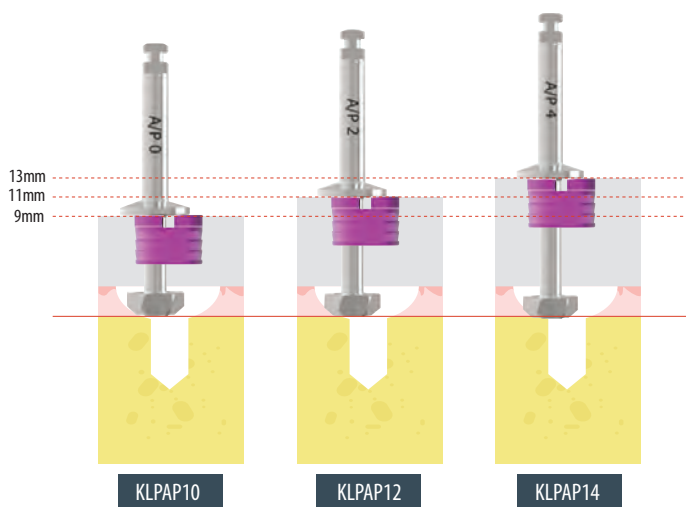

KLPAP10

KLPAP12

KLPAP14



Before use

After use

V Anchor - Fix Fixture

> 무치약과 같은 Case에서 Surgical Guide가 움직이지 않도록 먼저 식립되어 있는 Fixture에 Hex Driver로 체결하여 사용



*** Caution**

- > 반드시 체결된 Fixture의 Sleeve offset에 맞춰 체결
- > 기본구성에 Sleeve Offset 9mm용 V Anchor 포함(11,13mm용 별매)

V Anchor - Fix Bone

> 무치약과 같은 Case에서 Initial drilling 후 생성 된 Hole에 Torque Wrench를 사용하여 나사부를 고정시켜 Surgical guide가 움직이지 않도록 함



*** Caution**

- > 반드시 체결된 Fixture의 Sleeve offset에 맞춰 체결
- > 기본구성에 Sleeve Offset 9mm용 V Anchor 포함(11,13mm용 별매)

1.2 Hex Ratchet Driver

> Cover Screw나 Healing Abutment 체결 시 사용



Torque Wrench(Square)

- > Fixture 및 abutment 체결 시 torque force 조절을 위해 사용
- > Implant Adapter, Hex Driver 및 V anchor와 연결하여 사용
- > 탄성바로 10, 25, 30 & 35Ncm로 조절 가능
- > 최대 120Ncm

KTW001LP

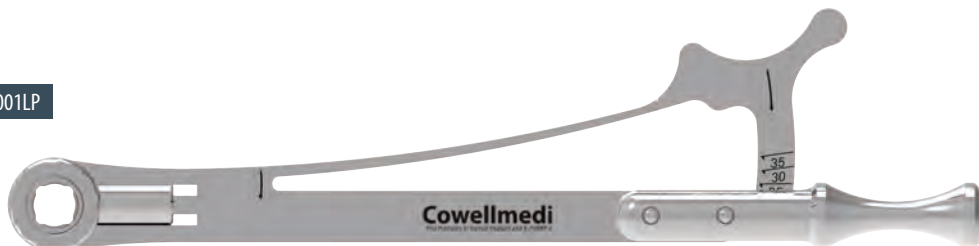

Sleeve

Extra



Closed Sleeve

KLPS01

* 포장단위 : 5 Sleeves

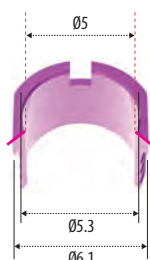

Open Sleeve

KLPS02

* 포장단위 : 5 Sleeves

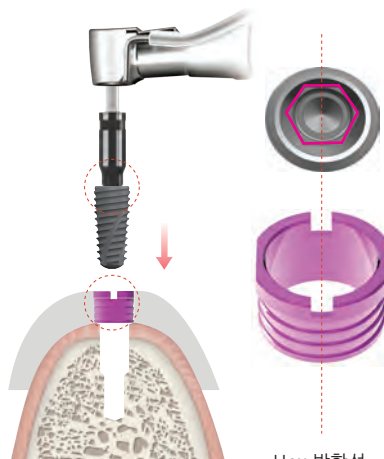

Hex 방향성 식별 홈

Anchor System

Extra

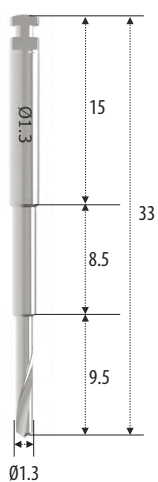

Anchor Drill

KLSAD13

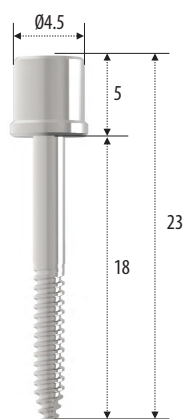

Anchor Screw

KLSAS18



Anchor Driver

KLSMD23

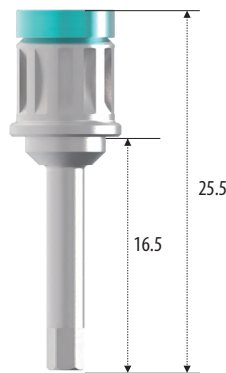

Anchor Driver

KLSRD16

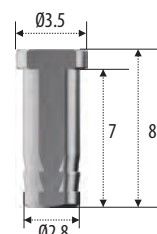

Anchor Sleeve

KLSAS01

* 포장단위 : 5 Sleeves

Drilling Sequence

Drilling Sequence (7~10mm)

INNO Sub Fixture Ø5 x 10mm

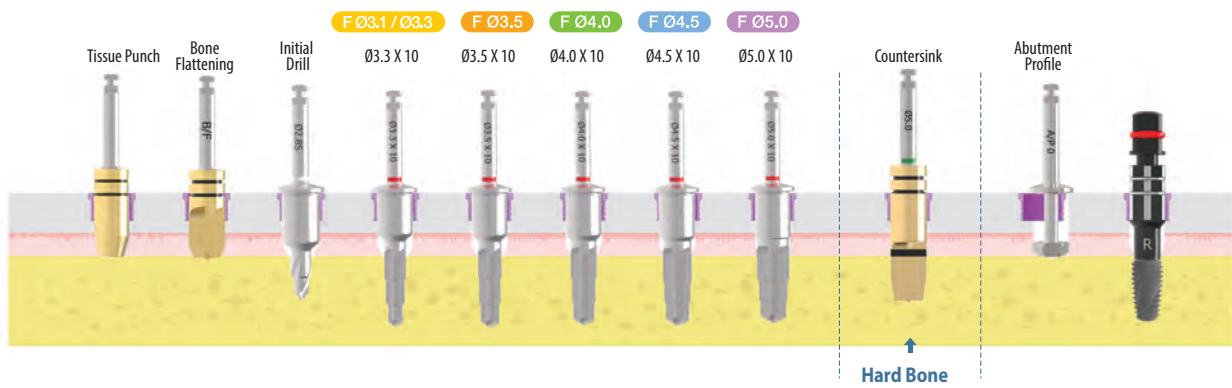

Drilling Sequence (12~14mm)

INNO Sub Fixture Ø5 x 14mm

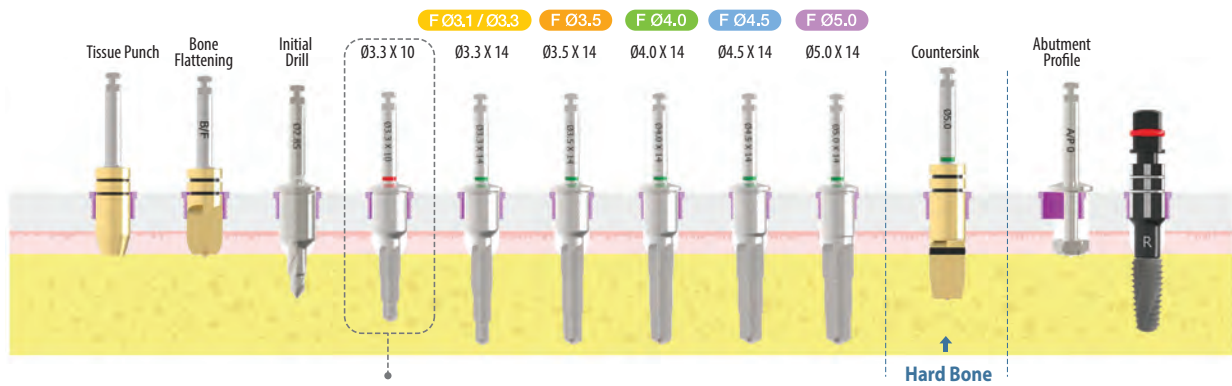

Sleeve Contact을 위해
8~10mm Drilling 미리 실시

*** Drilling 방법**

- > 이전 Drill과의 1차 Drill contact(A)과 Sleeve와의 2차 Sleeve contact(B)을 통하여 Path의 틀어짐 없이 술자가 원하는 방향으로 Drilling 가능
- > 이전 Drill을 사용하여 Hole 생성 후 다음 Drill을 이전 Hole에 삽입하여 Drill contact과 Sleeve contact(A및B)이 이루어진 뒤 Drilling 시도
- > Drill contact(A)가 이루어지지 않고 Sleeve contact(B)만으로 Drilling 시 Path가 부정확할 수 있음

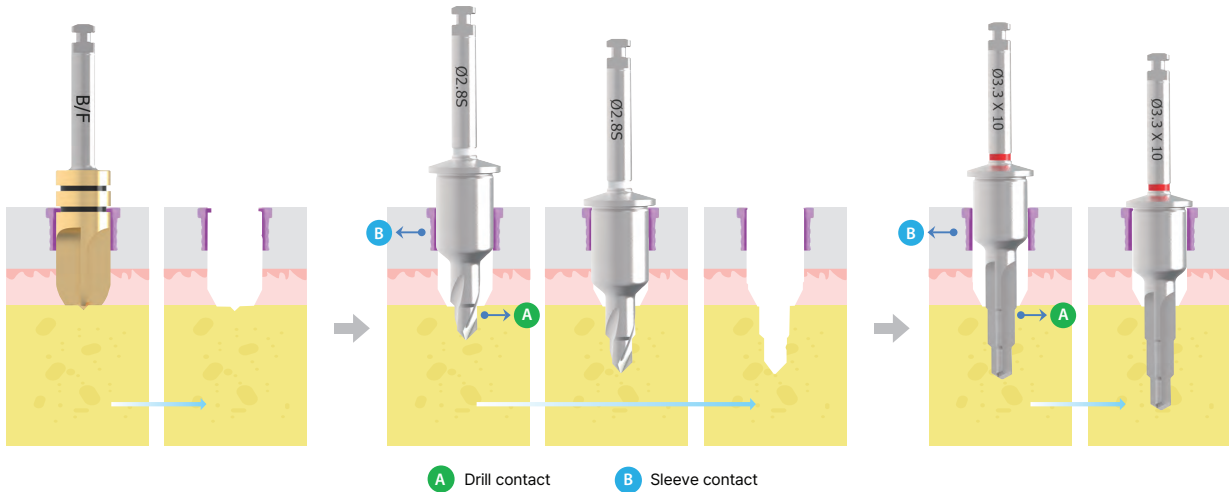
*** 주수 시 주의사항**

- > 주수 시 Drill Hole 하단 끝까지 충분히 주수

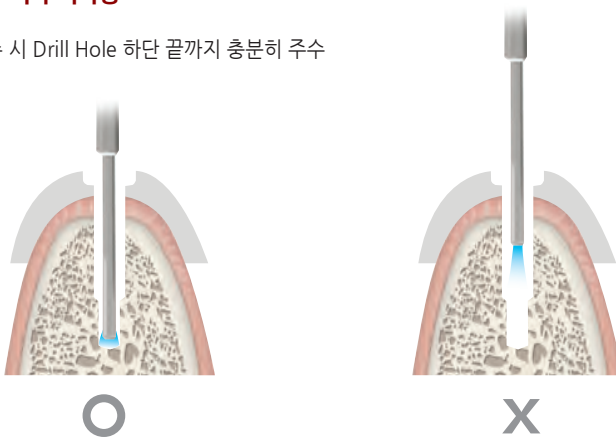

Drilling Sequence

> Tissue Punch, Bone Flattening Drill, Initial Drill, Pilot Drill, Abutment Profiler 및 Implant Adapter를 사용한 전체 드릴링 순서

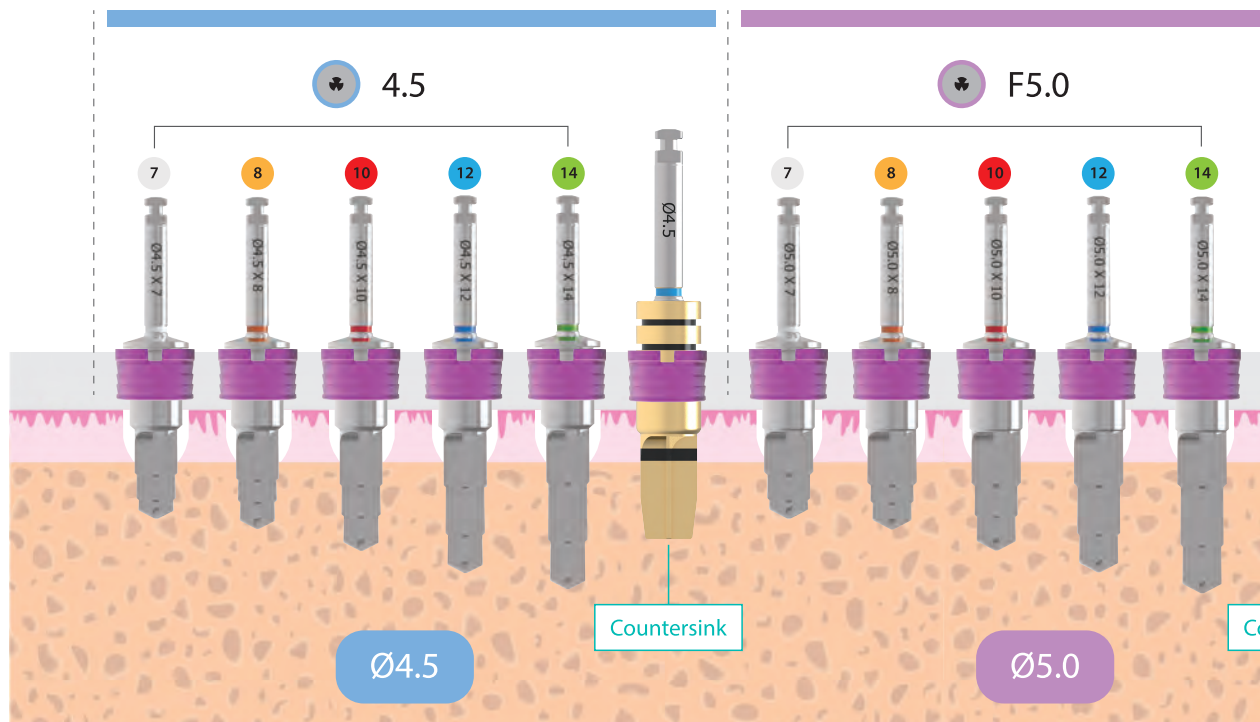
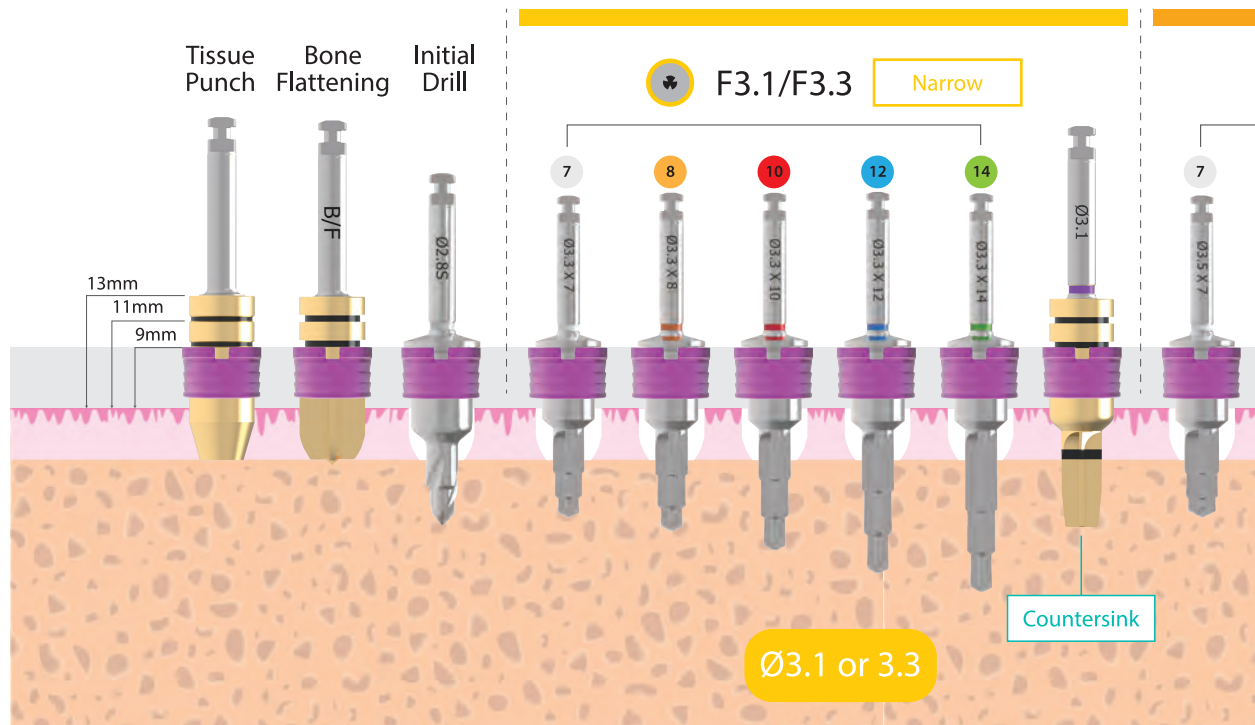

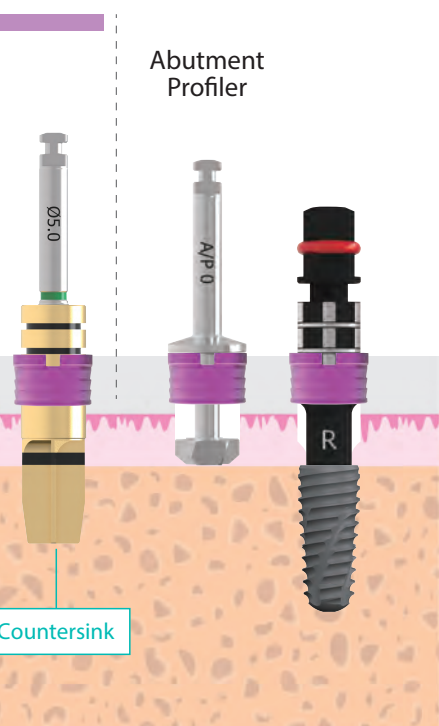
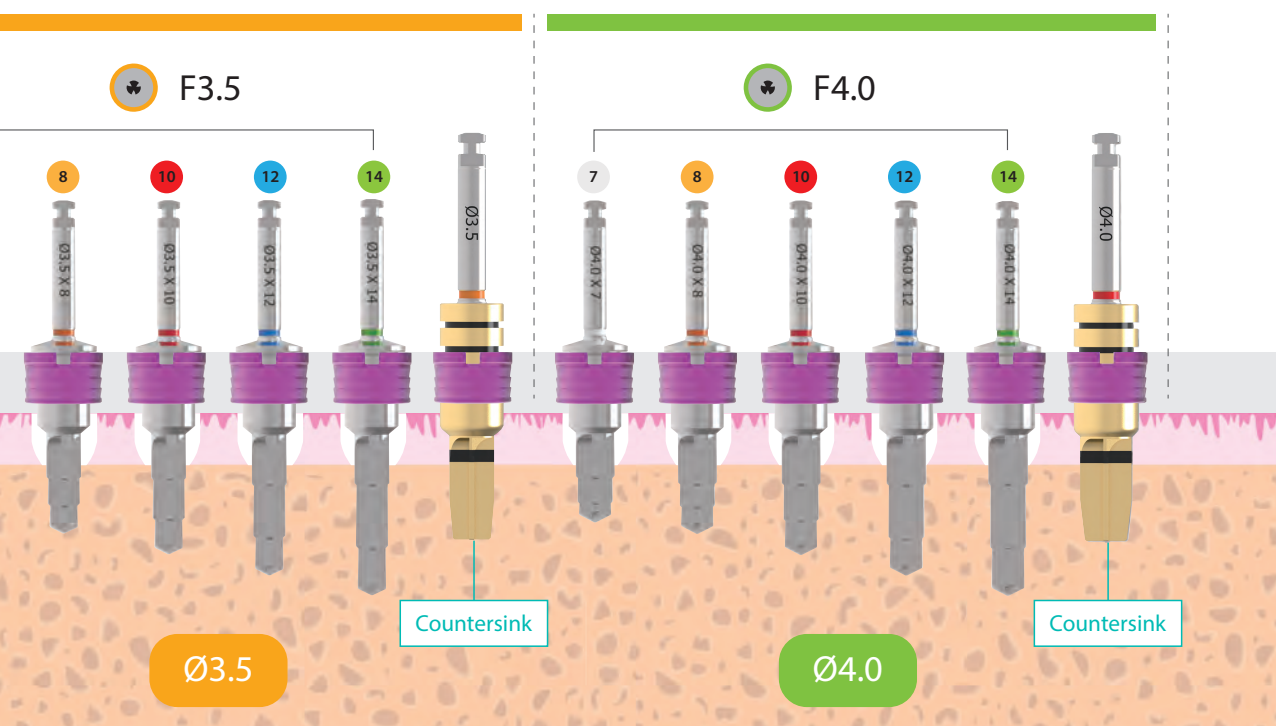

Lodestar Kit [KLS001]

- > 다양한 임상례에 적용 가능하며 경제적인 Guided surgery solution
- > 모든 Implant system에 적용 가능

Ø2.0 X 7 Ø2.0 X 8 Ø2.0 X 10 Ø2.0 X 12 Ø2.0 X 14



✦ Pilot Drill(Ø2.0)

KLSPD2007 KLSPD2008 KLSPD2010 KLSPD2012 KLSPD2014

Ø2.7 X 7 Ø2.7 X 8 Ø2.7 X 10 Ø2.7 X 12 Ø2.7 X 14



✦ Pilot Drill(Ø2.7)

KLSPD2707 KLSPD2708 KLSPD2710 KLSPD2712 KLSPD2714

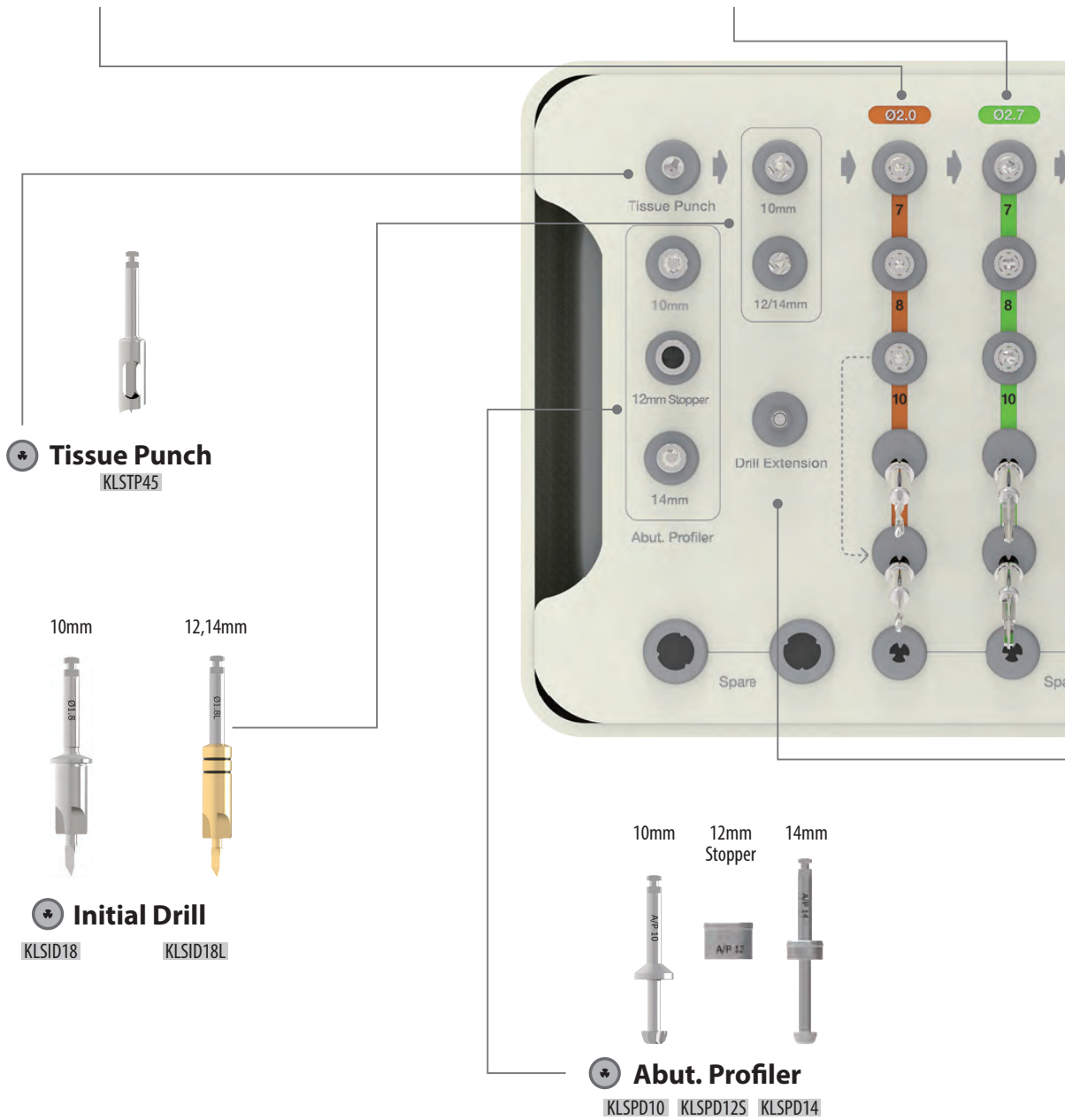

Ø3.4 X 7 Ø3.4 X 8 Ø3.4 X 10 Ø3.4 X 12 Ø3.4 X 14



⊕ Pilot Drill(Ø3.4)

KLSPD3407 KLSPD3408 KLSPD3410 KLSPD3412 KLSPD3414

Ø4.2 X 7 Ø4.2 X 8 Ø4.2 X 10 Ø4.2 X 12 Ø4.2 X 14

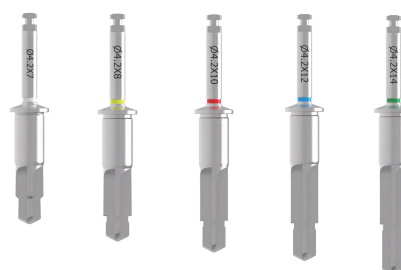

⊕ Pilot Drill(Ø4.2)

KLSPD4207 KLSPD4208 KLSPD4210 KLSPD4212 KLSPD4214



Anchor Drill Anchor Screw Anchor Driver

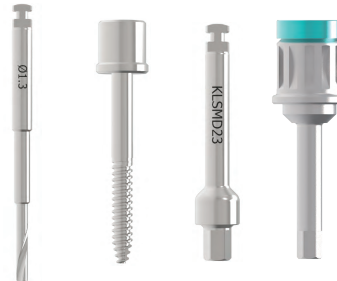

⊕ Anchor System

KLSAD13 KLSAS18 KLSMD23 KLSRD16



⊕ Drill Extension

KDE002

Tissue Punch

> Fixture를 식립 할 위치의 치은을 원형으로 절개하며 경사진 Bone에서도 사용 가능 (무주수 50 rpm).

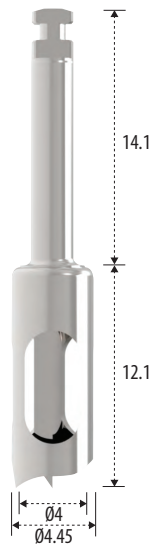

KLSTP45

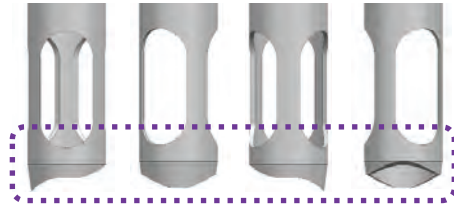

Bone level이 평행하지 않거나 경사진 경우에도 잇몸을 원형으로 절개 가능

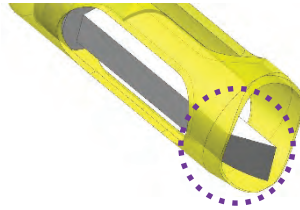

Tissue Punch 내부의 절삭날부가 잇몸을 분쇄시켜 별도의 제거 작업이 없이 Suction으로 흡입 가능



Initial Drill

> Bone Flattening Drill과 Point Drill을 합친 Drill로 별도의 Bone Flattening Drill이 불필요하며 시술 시간이 단축되어 간편 (주수 1,000 rpm)

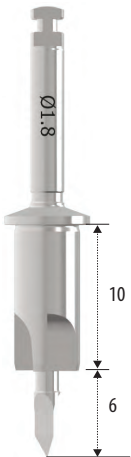

KLSID18

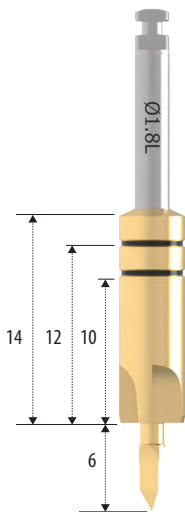

KLSID18L

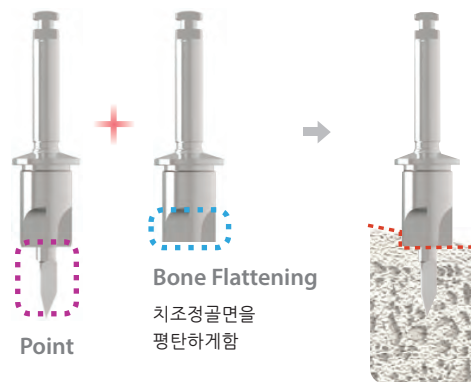

Point

Bone Flattening

치조정골면을 평탄하게함

Bone 표면에 홈을 만들어 다음에 사용하는 Drill의 축이 흔들리지 않도록 하며, 경사진 Bone level에서도 미끄러짐 없이 Drill position을 Guide

Pilot Drill

> Ø2.0 / Ø2.7 / Ø3.4 / Ø4.2.

Ø2.0: High Speed - 600rpm

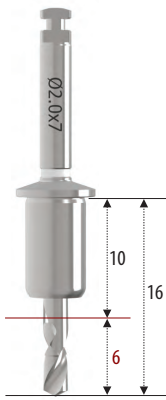

Pilot Drill 16mm(6mm)

KLSPD2007

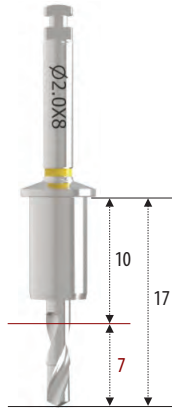

Pilot Drill 17mm(7mm)

KLSPD2008

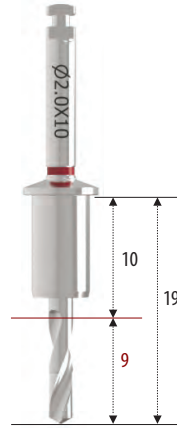

Pilot Drill 19mm(9mm)

KLSPD2010

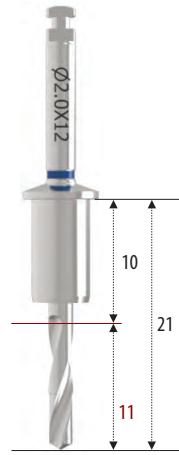

Pilot Drill 21mm(11mm)

KLSPD2012

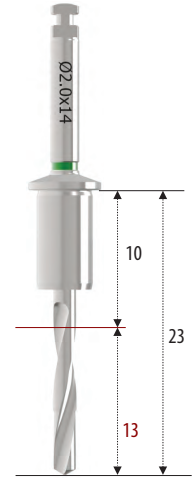

Pilot Drill 23mm(13mm)

KLSPD2014

Ø2.7 / Ø3.4 / Ø4.2: Low Speed - 50~200rpm / 50N.cm

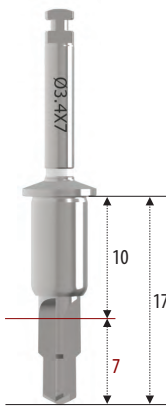

Pilot Drill 17mm(7mm)

KLSPD2707

KLSPD3407

KLSPD4207

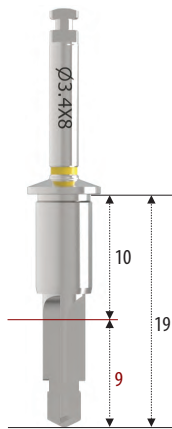

Pilot Drill 19mm(9mm)

KLSPD2708

KLSPD3408

KLSPD4208

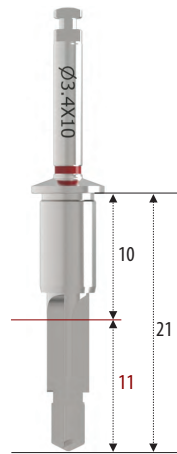

Pilot Drill 21mm(11mm)

KLSPD2710

KLSPD3410

KLSPD4210

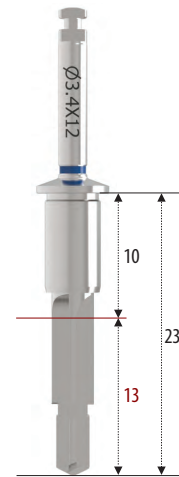

Pilot Drill 23mm(13mm)

KLSPD2712

KLSPD3412

KLSPD4212

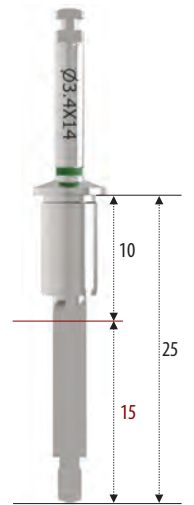

Pilot Drill 25mm(15mm)

KLSPD2714

KLSPD3414

KLSPD4214

Abutment Profiler

> Abutment 체결 시 방해가 되는 치조골 제거

KLSPD10

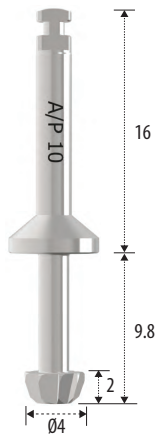

Offset - 10mm

KLSPD14 + KLSPD12S



Offset - 12mm

KLSPD14

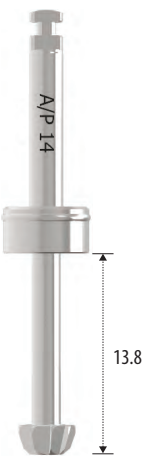

Offset - 14mm

KLSPD12S

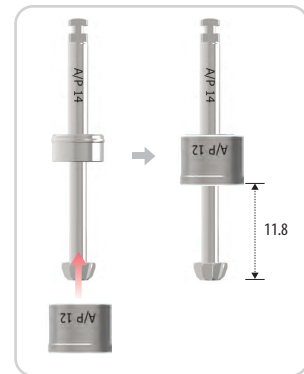
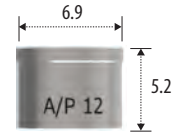

* 14mm Drill에 Stopper를 장착하여 12mm Drill로 사용

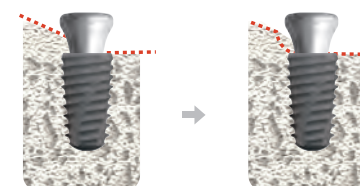
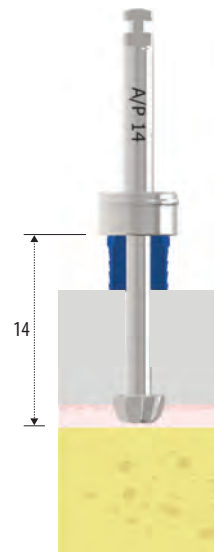
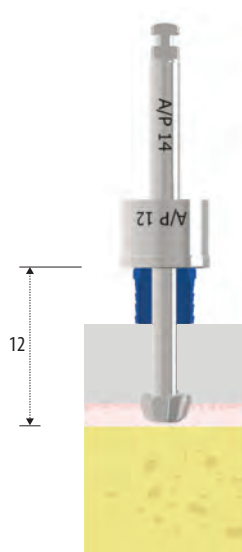
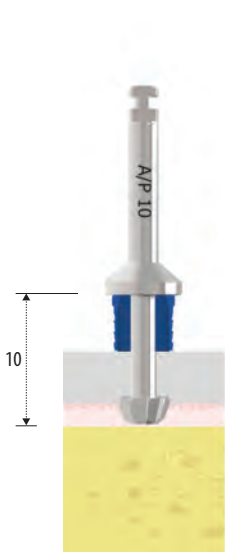

*** Offset 길이 설정**

- > Sleeve 상단에서 Fixture platform 사이의 기본 길이는 10mm
- > 잇몸이 두꺼운 환자나 Bone이 좋지 않아 Fixture를 더 깊이 식립하여야 할 경우 Sleeve를 상단으로 2, 4mm를 거상하여 사용
- > Offset 값을 올릴수록 정확도가 떨어지기에 가능한 10mm로 사용 권장

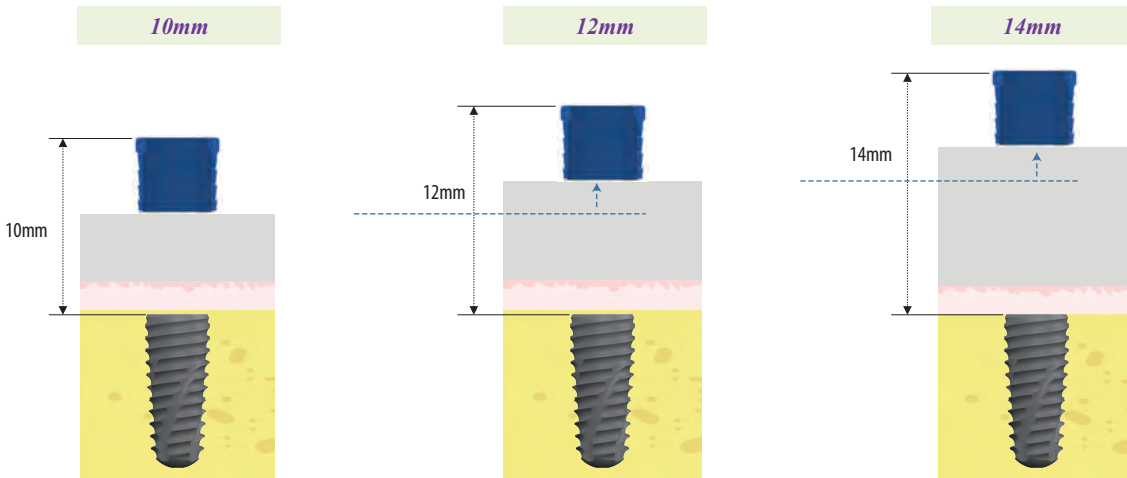

Anchor System

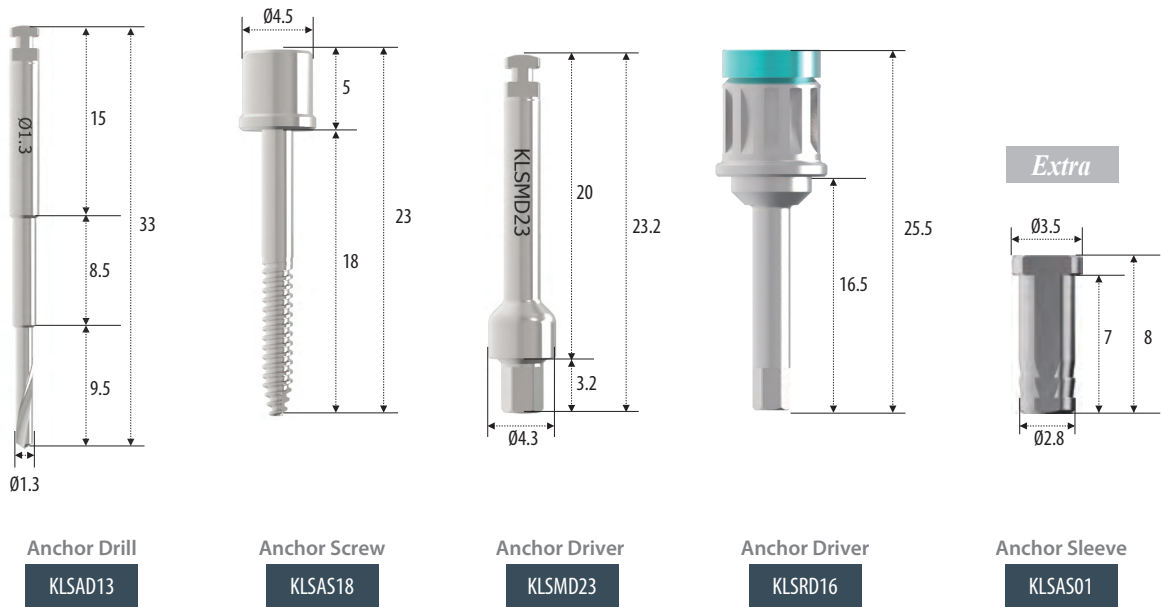

* 포장단위 : 5 Sleeves

Guide Reamer **Extra**

Drill과 Sleeve가 정확히 Contact 될 수 있도록 Hole 생성(Sleeve/Non Sleeve)
 4.5mm Reamer는 Non Sleeve 용, 5.3mm Reamer는 Sleeve 용으로 사용 (800 rpm 무주수)

Guide Reamer
(Non-Sleeve)
KLSRD45

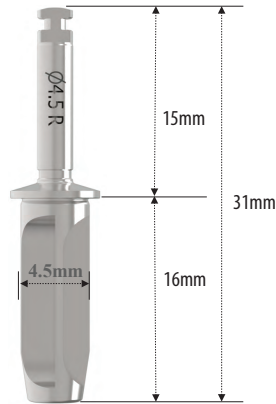

Guide Reamer
(Sleeve)
KLSRD53

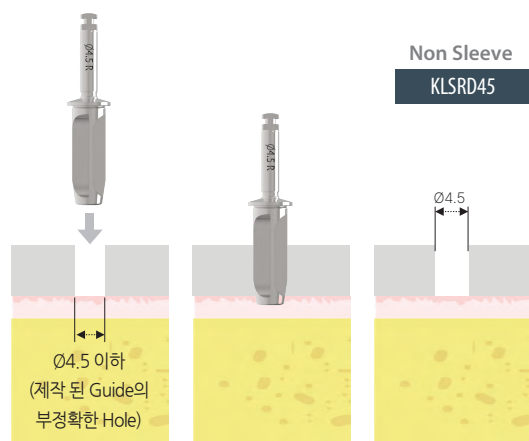
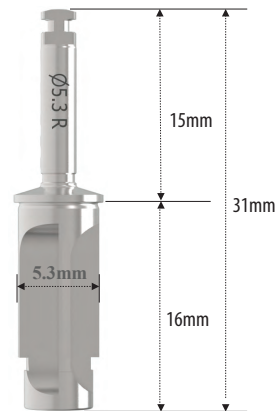

제작된 Guide의 부정확한 내부 Hole에 4.5 Reamer를 사용하여 Drill에 정확히 Contact 될 수 있도록 Hole 생성

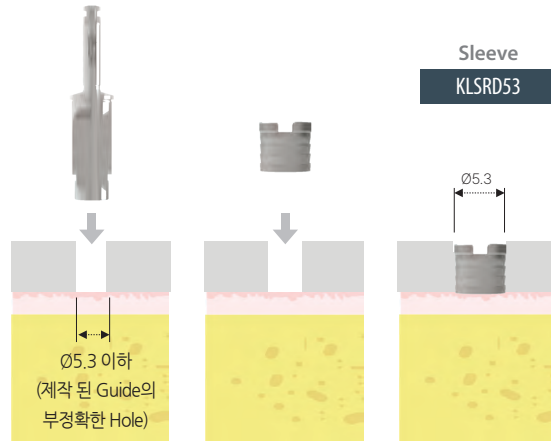

제작된 Guide의 부정확한 내부 Hole에 5.3 Reamer를 사용하여 Sleeve를 정확히 체결할 수 있도록 Hole 생성

Sleeve *Extra*

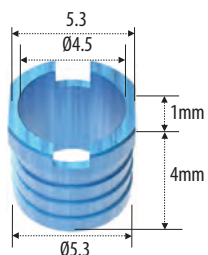

Closed Sleeve

KLSS01

* 포장단위 : 5 Sleeves

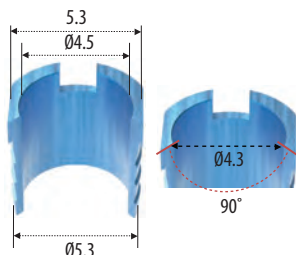

Open Sleeve

KLSS02

* 포장단위 : 5 Sleeves

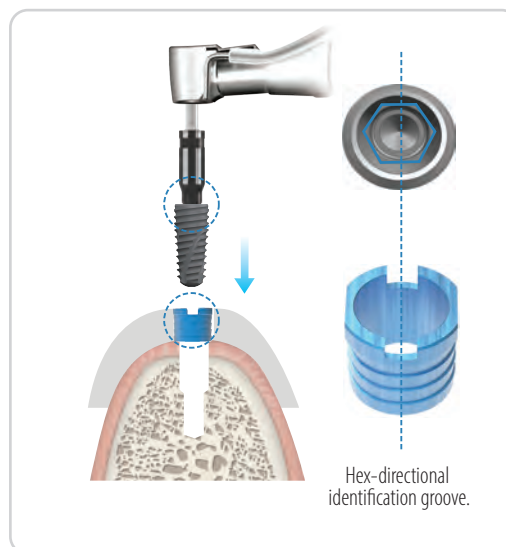

Pilot Drill – 16/18mm *Extra*

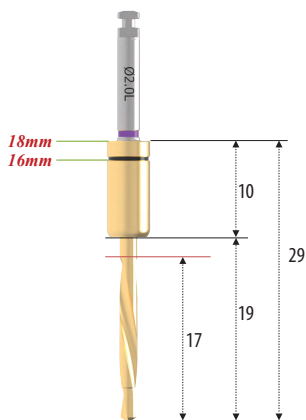

KLSPD2018

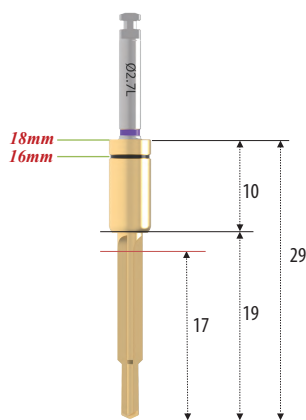

KLSPD2718

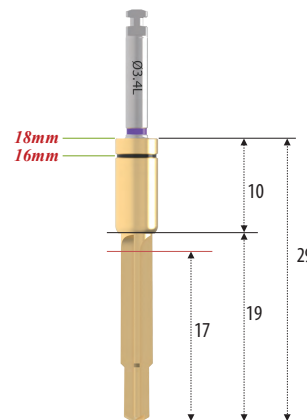

KLSPD3418

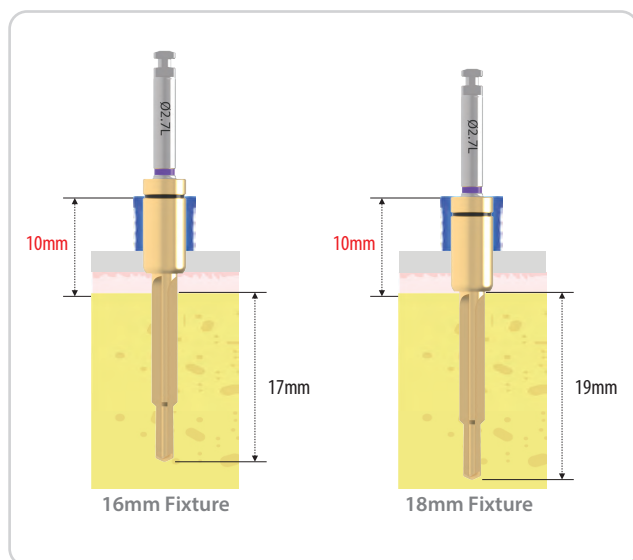

Drilling Sequence

Drilling Sequence (without sleeve)

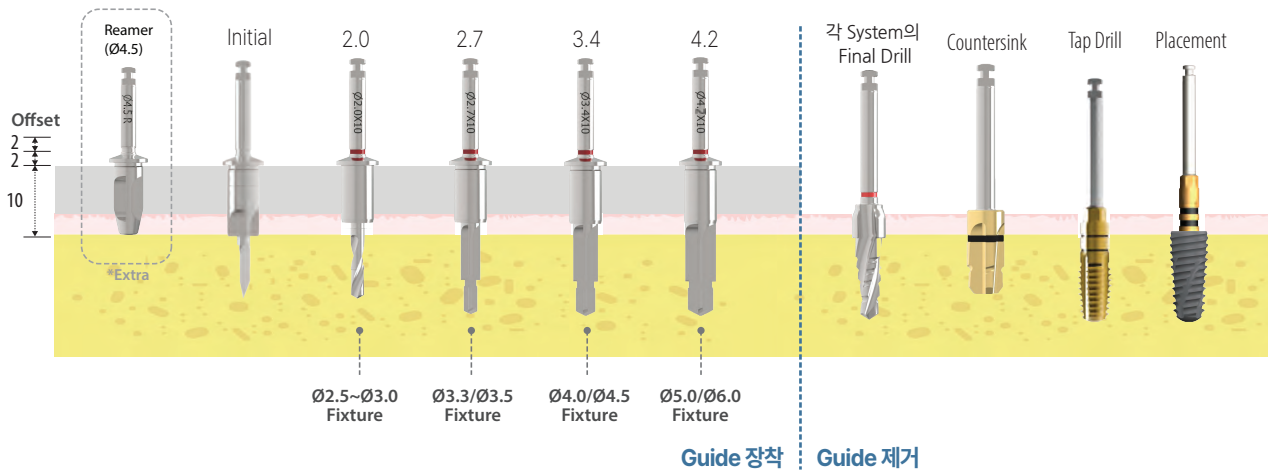

Drilling Sequence (with sleeve)

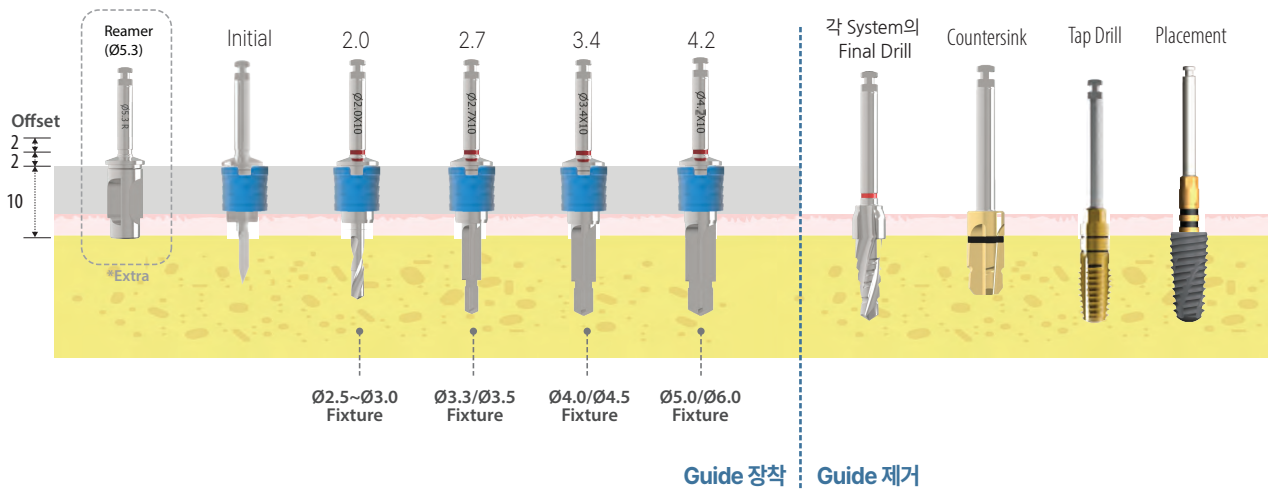

*** Drill과 Sleeve의 Contact을 위하여 10mm Drill 사용 후 14mm Drill 사용**

Drill과 Sleeve의 정확한 Contact을 위하여 14mm Drill의 경우, Ø2.0X10 Drill 우선 사용 후 14mm Drill 사용

e.g.) 3.4 X 14mm Drilling Sequence

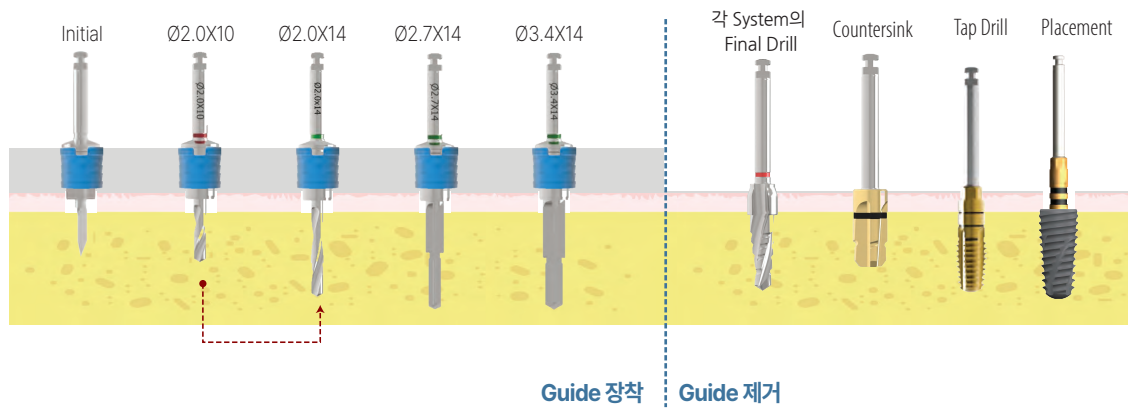

*** Drilling 방법**

- > 이전 Drill과의 1차 Drill contact(A)과 Sleeve와의 2차 Sleeve contact(B)을 통하여 Path의 틀어짐 없이 술자가 원하는 방향으로 Drilling 가능
- > 이전 Drill을 사용하여 Hole 생성 후 다음 Drill을 이전 Hole에 삽입하여 Drill contact과 Sleeve contact(A및B)이 이루어진 뒤 Drilling 시도
- > Drill contact(A)가 이루어지지 않고 Sleeve contact(B)만으로 Drilling 시 Path가 부정확할 수 있음

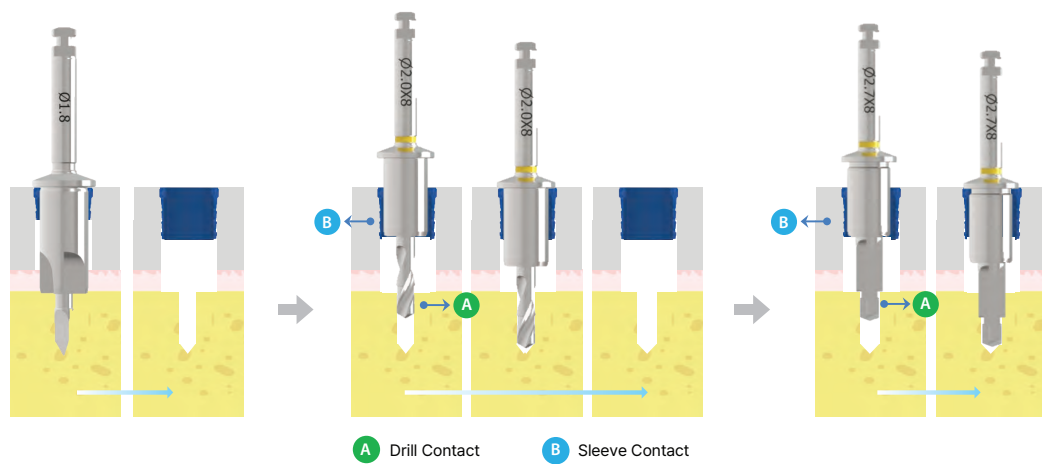

***주수 시 주의사항**

> 주수 시 Drill Hole 하단 끝까지 충분히 주수

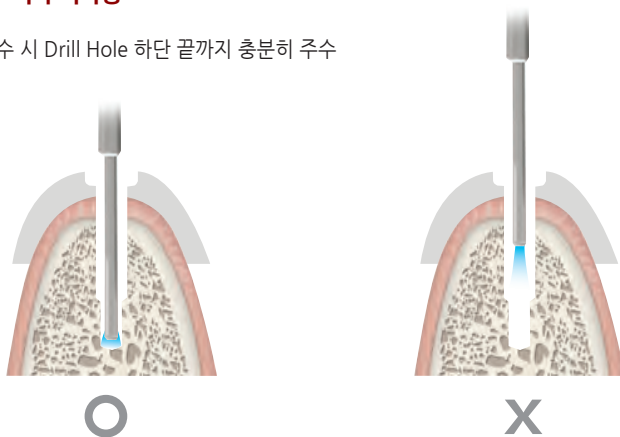

Drilling Sequence

> Tissue Punch, Initial Drill, Pilot Drill 및 Abutment Profiler를 사용한 전체 드릴링 순서

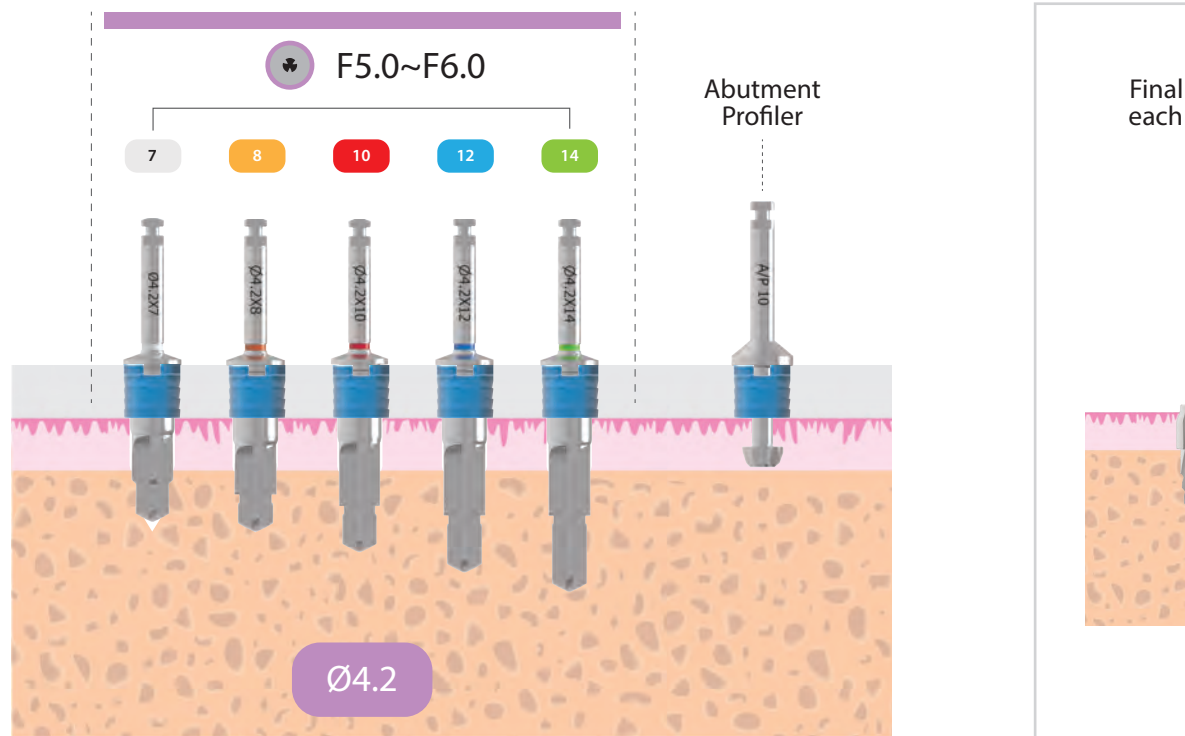
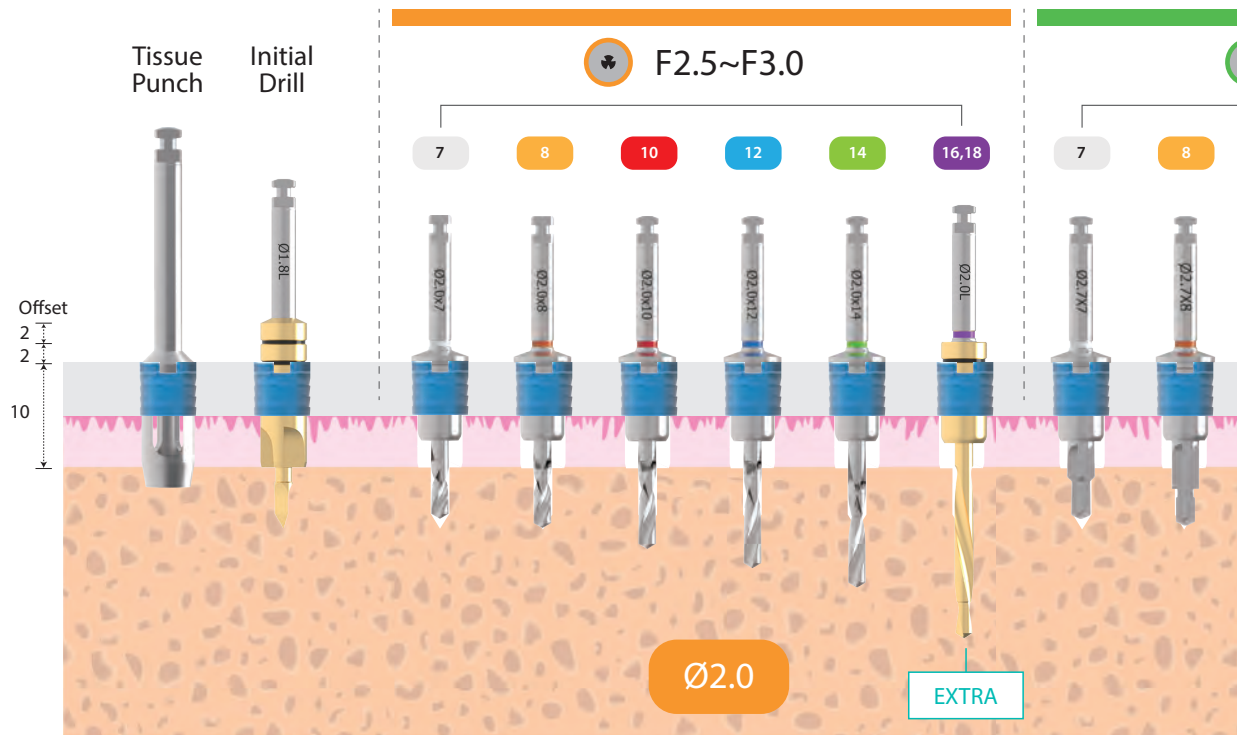

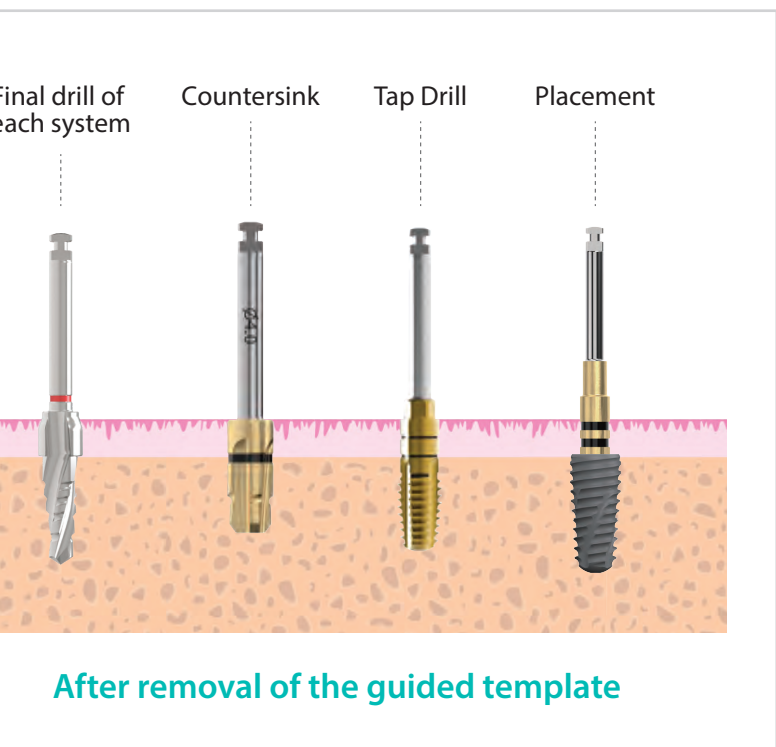
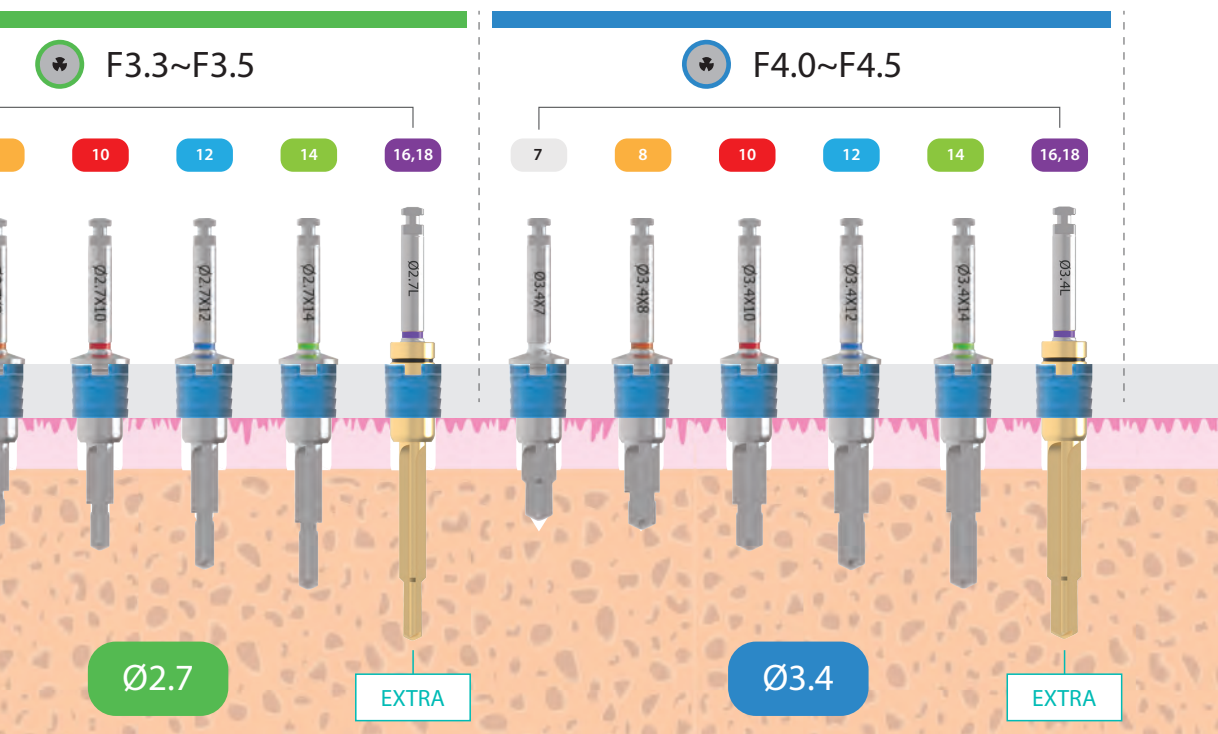

Lodestar Sinus Kit [KLSS001]

- > 가이드를 이용한 안전하고 정확한 상악동 거상 (가이드 장착 후 수압거상 가능)
- > Lodestar Plus Kit와 동일한 Sleeve를 사용함으로써 모든 drill 및 기구 호환 사용 가능

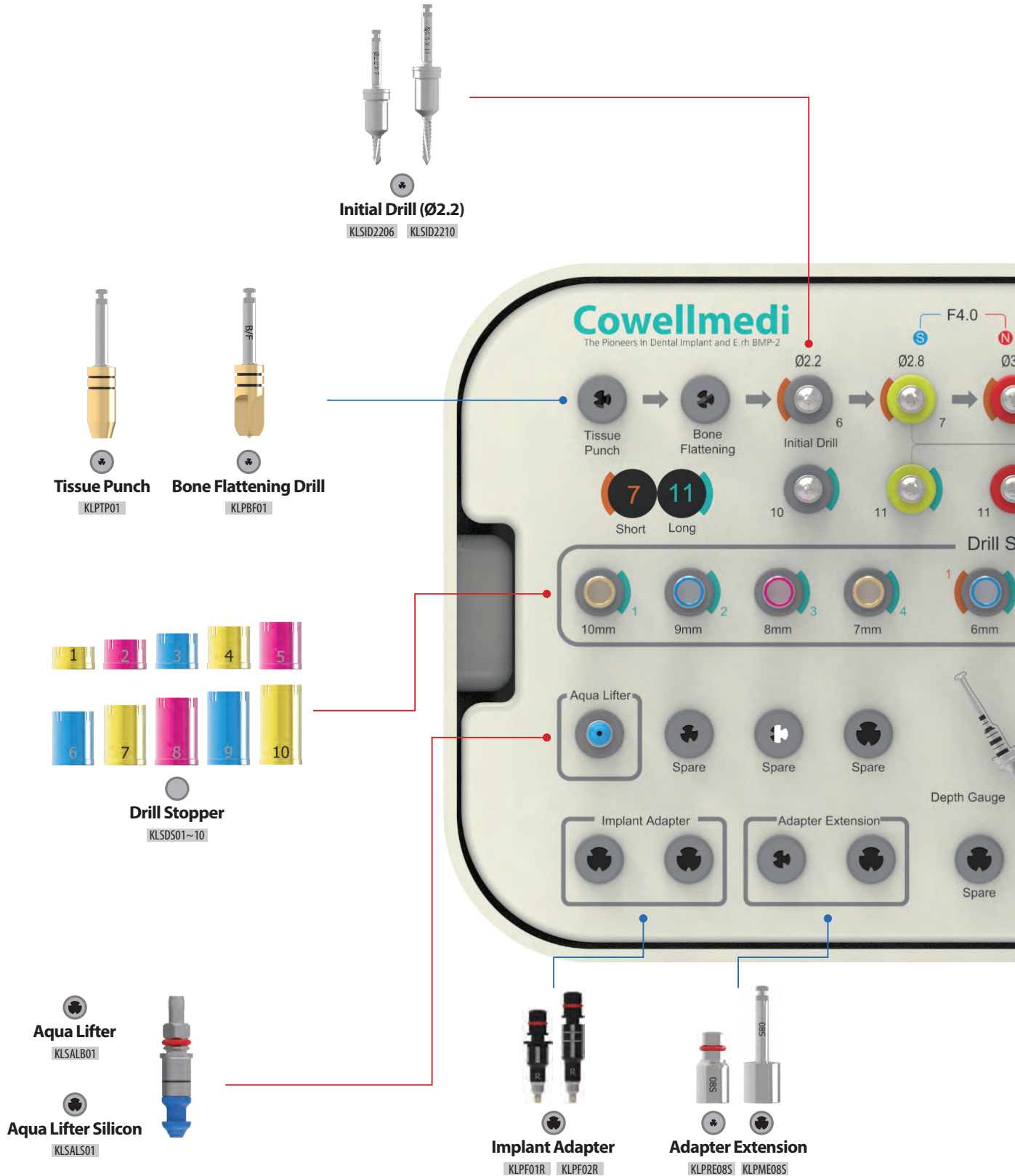



Crestal Drill
(Ø2.8/3.3/3.7/4.2)

KLSCD2807 KLSCD2811 KLSCD3307 KLSCD3311 KLSCD3707 KLSCD3711 KLSCD4207 KLSCD4211

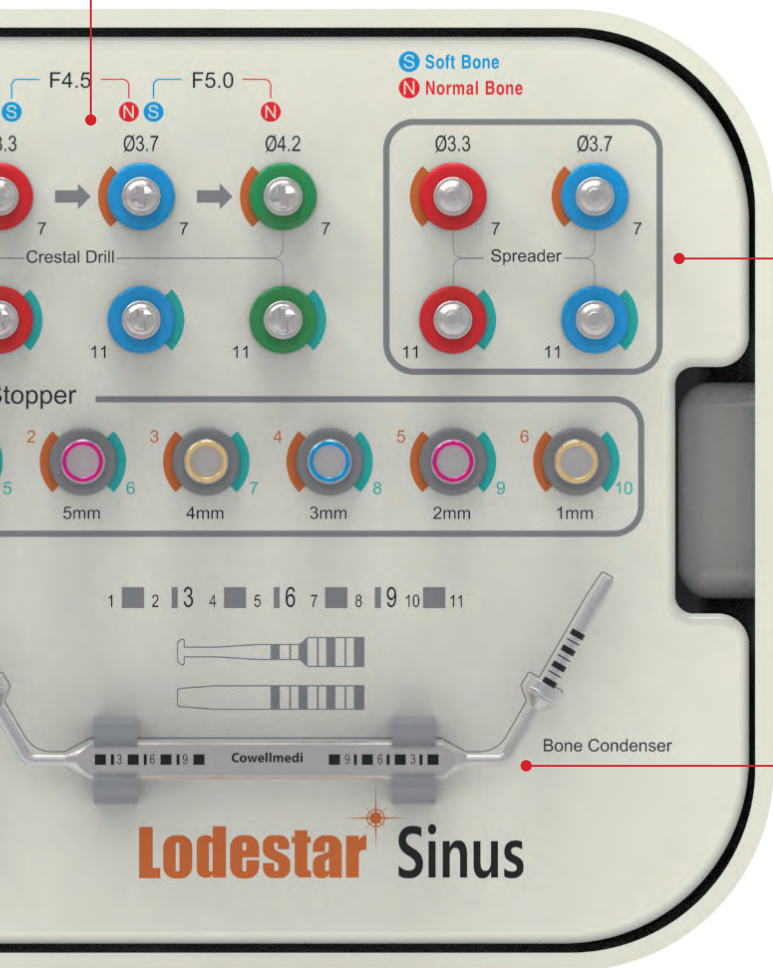

Spreader
(Ø3.3/3.7)

KLSSD3307 KLSSD3311 KLSSD3707 KLSSD3711



MF Controller

KL5MFC

● 기본 구성
● 별매품

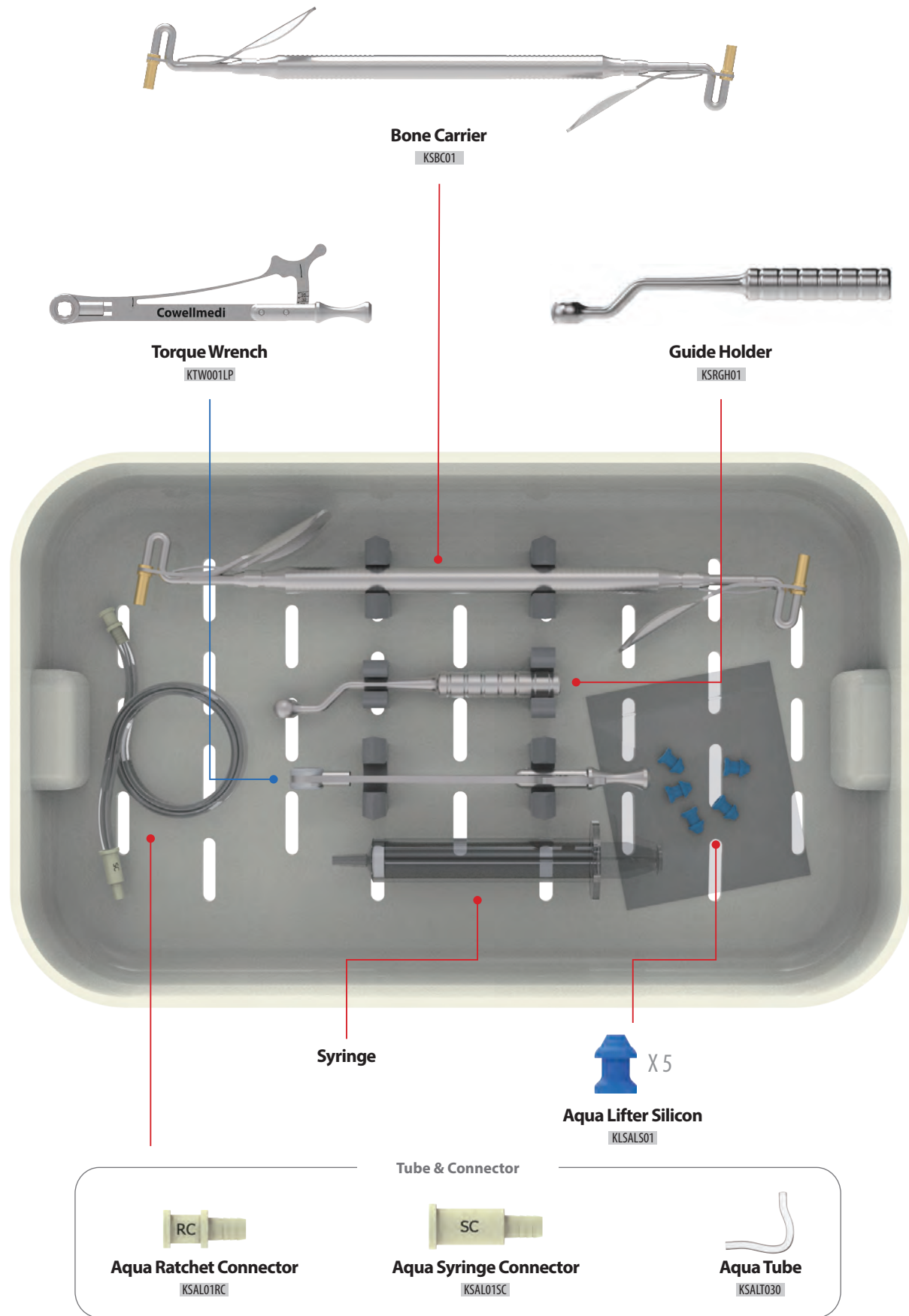

Bone Carrier
KSBC01

Torque Wrench
KTW001LP
Cowellmedi

Guide Holder
KSRGH01

Syringe

Aqua Lifter Silicon
KLSALS01 X5

Tube & Connector

Aqua Ratchet Connector
KSAL01RC

Aqua Syringe Connector
KSAL01SC

Aqua Tube
KSALT030

● 기본 구성
● 별매품

Drill Stopper

- > 잔존골 높이에 따라 순차적으로 Drill Stopper 사용
- > 길이별 Color 적용
- > Drill과 체결 시 Drilling되는 깊이 표기 : 7mm Drill - Orange, 11mm Drill - Blue
- > 1mm 단위로 1mm에서 10mm까지 구성되어 있어 안정적인 Drilling 깊이 조절 가능

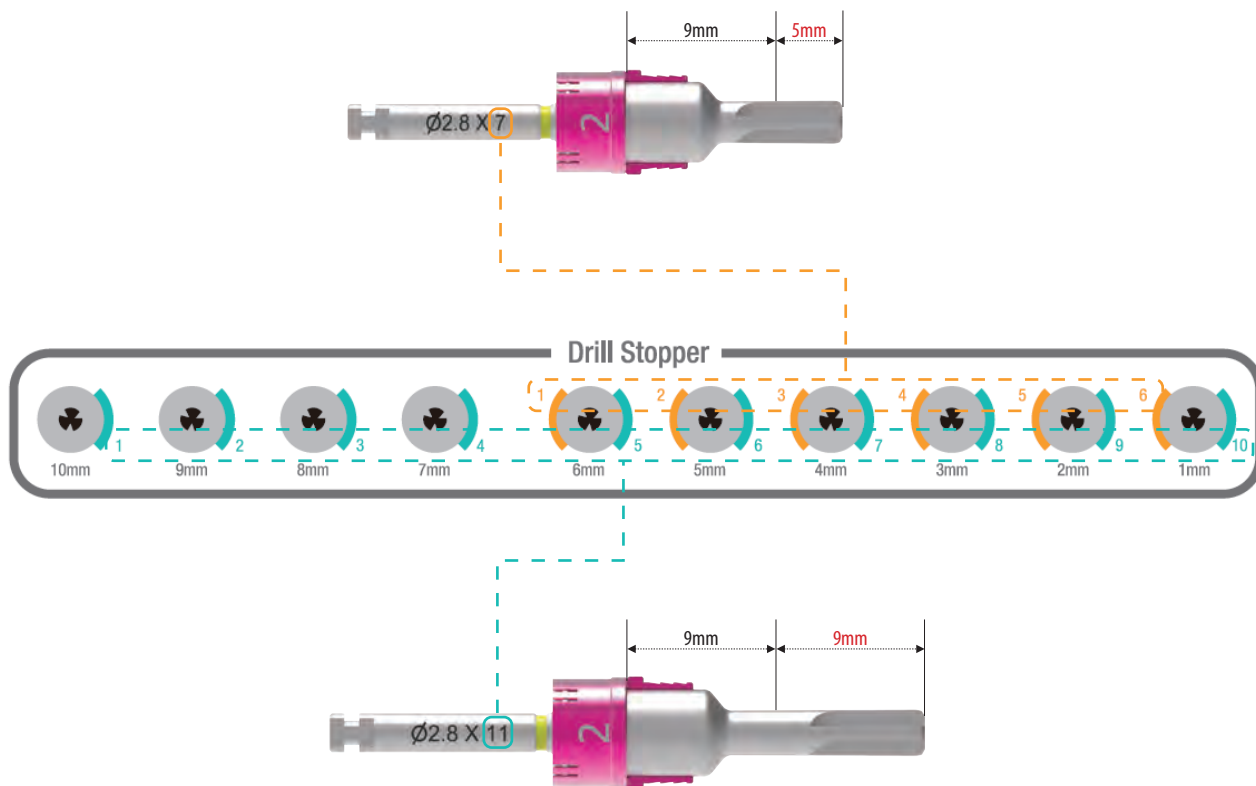

· H(mm)

Drill Stopper Selection Guide

> Drill - Offset 9mm 기준

1. 잔존골 높이에 따른 Stopper 선택

· Drill Length(L) - 잔존골 높이(B) = Drill Stopper(D.S)

예) 잔존골의 높이(B)가 4mm일 경우

· Short Drill : 7(Drill Length) - 4(잔존골 높이) = 3(Drill Stopper)

· Long Drill : 11(Drill Length) - 4(잔존골 높이) = 7(Drill Stopper)

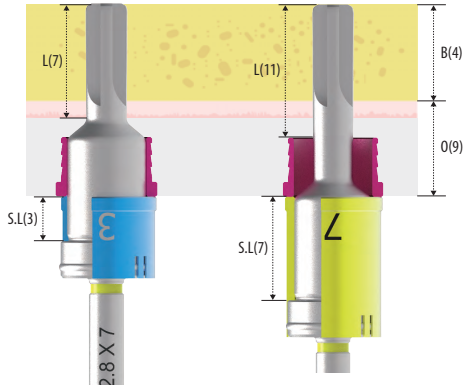

2. Total Length(Surgical Guide Top - Membrane)에 따른 Stopper 선택

· Drill height(D.H) - Total Length(T.L) = Drill Stopper(D.S)

예) Total length가 13mm일 경우

· Short Drill : 16(Drill Height) - 13(Total Length) = 3(Stopper Length)

· Long Drill : 20(Drill Height) - 13(Total Length) = 7(Stopper Length)

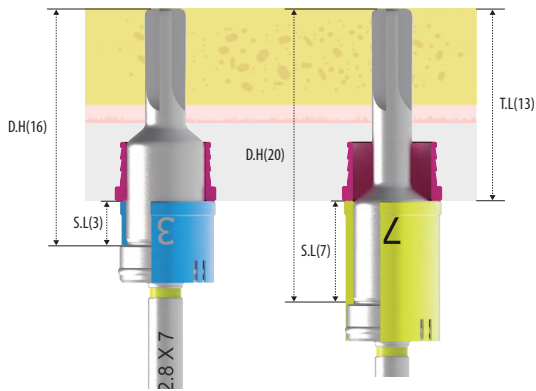

3. MF Controller

· Long Drill 기준 Stopper 사용

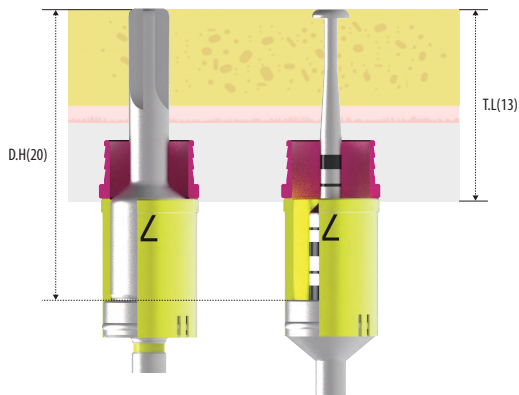

- > S.L : Stopper Length
- > T.L : Total Length
- > D.H : Drill Height
- > B : Residual Bone Height (잔존골)
- > O : Offset
- > L : Drill Length

* Offset이 11mm일 경우 2mm 더 짧은 Drill Stopper를 사용하고 13mm일 경우 4mm 더 짧은 Drill Stopper 사용

Drill Stopper에 따른 Drilling 깊이

> 7mm Drill + Drill Stopper

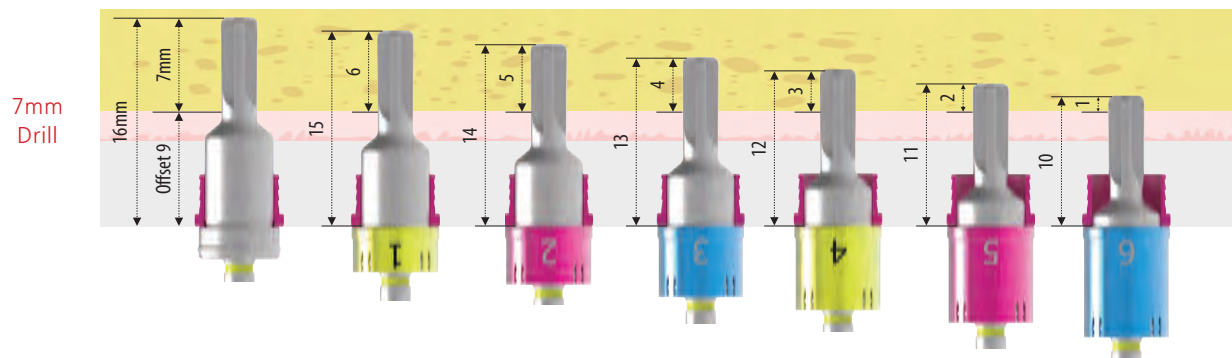

> 11mm Drill + Drill Stopper

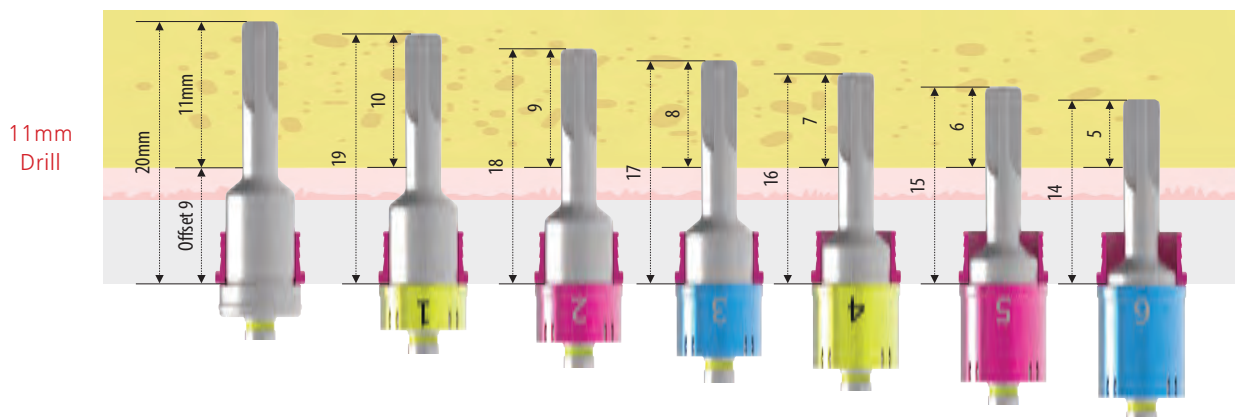

Tissue Punch **Extra**

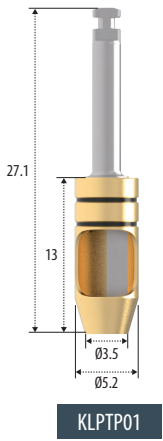

- > Soft tissue 제거 시 사용(시술 위치의 치은을 원형으로 절개)
- > 작은 직경의 Punch로 인하여 시술 후 지혈효과, 작은 시술흔적, 빠른 창상 치유의 효과 발생
- > Offset 적용 가능(9mm, 11mm, 13mm)
- > 무주수 50rpm

Double blade
 내부 고정날부가 잇몸을 분쇄 시켜 별도의 제거 작업이 없이 Suction으로 흡입하여 안정적으로 Gingiva 제거 가능

*** Caution** 수술 후 Tissue punch 내부에 분쇄된 잇몸등의 잔여물이 남을 시 녹 발생, 날 부 손상의 문제가 발생하므로 깨끗이 관리 필요(Explorer 및 Steam등으로 잔여물 제거)

Bone Flattening Drill **Extra**

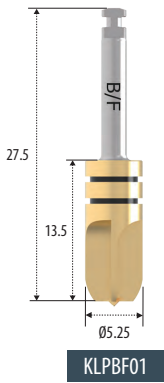

- > 시술 부위의 치조정 골면(Bone Level) 평탄하게 만들
- > Bone Level이 경사져 있을 경우 Drill이 미끄러져 계획대로 Drilling 되지 않을수 있음
- > Tissue Punch 사용 후 남아 있는 연조직을 제거
- > 중앙의 Point부가 다음 Drill의 Guide 역할을 하여 정확한 위치에 Drilling 가능
- > Offset 적용 가능(9mm, 11mm, 13mm)
- > 무주수 400rpm / 주수 800 rpm



Initial Drill

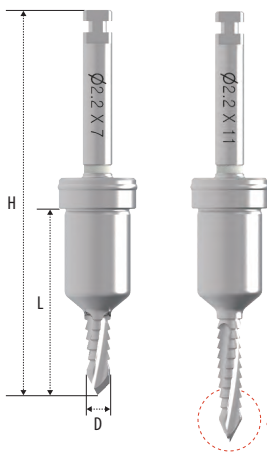

- > Crestal Drill 사용전, Guide hole 생성 시 사용
- > Point + Lindermann Drill 기능으로 경사진 본에 미끄러지지 않고 원하는 방향으로 드릴링 가능
- > 잔존골높이에 따라 드릴 스톱퍼와 함께 사용
- > 표기길이(Crestal Drill)보다 1mm 짧음
- > 권장속도 : 800~1000rpm

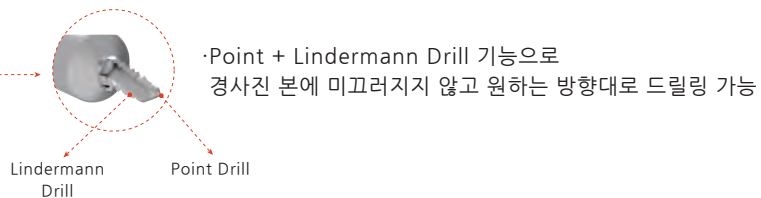

Code	D(Ø)	L(mm)	H(mm)	Color Band
KLSID2206	2.2	15	31	White
KLSID2210	2.2	19	35	White

* Crestal Drill : L-1mm

Crestal Drill

- > 상악동 시술 시 membrane 안전하게 거상 가능(드릴 엣지부 라운드 디자인)
- > 안전한 거상을 위해 잔골골 높이에 따라 Drill Stopper를 체결하여 사용
- > 골질(Soft,Normal)에 따라 Final Drill 직경 선택
- > 드릴링 시 자가골 채취 가능
- > 권장속도 : 500~800 rpm

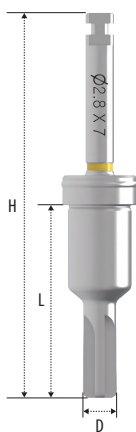

※ Flat floor edge minimize damage to membrane

Code	D(Ø)	L(mm)	H(mm)	Color Band
KLSCD2807	2.8	16	32	Yellow
KLSCD2811	2.8	20	36	Yellow
KLSCD3307	3.3	16	32	Red
KLSCD3311	3.3	20	36	Red
KLSCD3707	3.7	16	32	Blue
KLSCD3711	3.7	20	36	Blue
KLSCD4207	4.2	16	32	Green
KLSCD4211	4.2	20	36	Green

Crestal Drill - 7mm

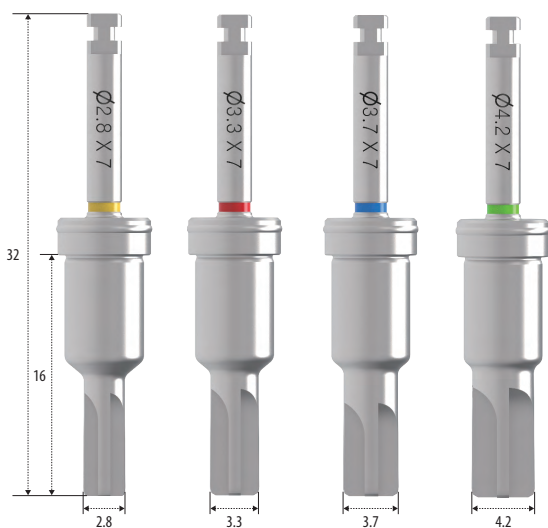

Crestal Drill - 11mm

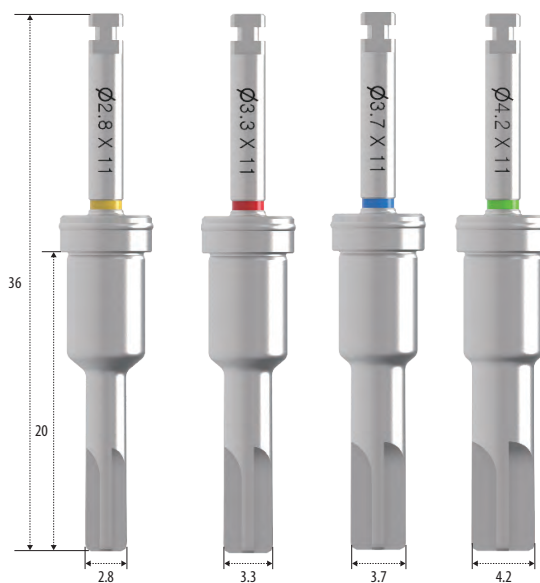

Yellow	Ø2.8
Red	Ø3.3
Blue	Ø3.7
Green	Ø4.2

Spreader

- > 잔존골의 높이가 4mm이상일 경우 20~30RPM으로 천천히 상악동 천공을 할 경우 사용
- > 테이퍼 디자인으로 본을 압축시켜 초기 고정력 상승
- > 잔존골 높이에 따라 Drill Stopper를 체결하여 사용
- > 권장속도 : 20~30 rpm / 45Ncm

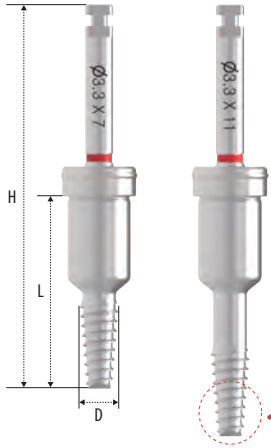

* 선단의 절삭날이 천천히 본을 절삭하여 안전하게 상악동막 거상

Code	D(Ø)	L(mm)	H(mm)	Color Band
KLSSD3307	3.3	16	32	Red
KLSSD3311	3.3	20	36	Red
KLSSD3707	3.7	16	32	Blue
KLSSD3711	3.7	20	36	Blue

Aqua membrane Lifter System

> 상악동 하연골의 거상이 제대로 되었는지 확인 후 Aqua Membrane Lifter System을 이용하여 Membrane을 거상

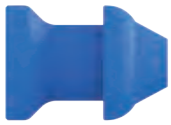

Aqua Lifter Silicon

KLSALS01

* 일회용 의료기기

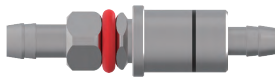

Aqua Lifter

KLSALB01



Aqua Ratchet Connector

KSAL01RC

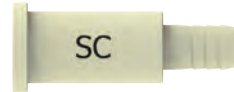

Aqua Syringe Connector

KSAL01SC



Aqua Tube

KSALT030

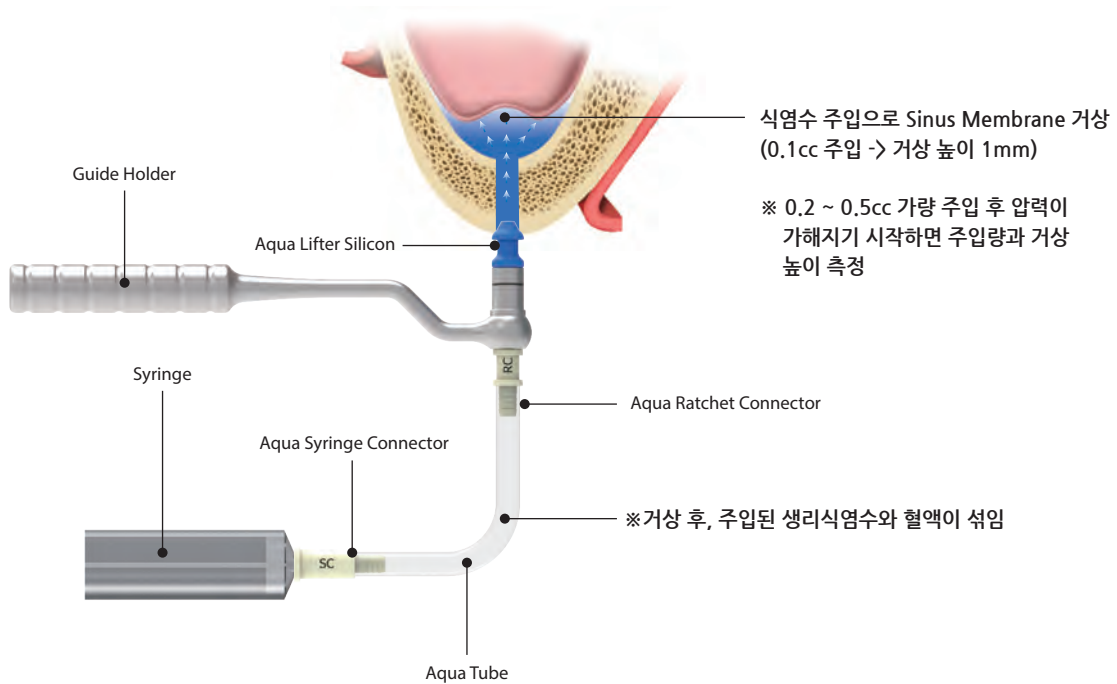

MF Controller

- > 하나의 Tool로 Depth Gauge와 Bone Condenser 공용 사용
- > 안전한 거상을 위해 Drill stopper 체결하여 사용
- > 11mm Drill(H 20mm)과 길이가 같으며 1 mm 단위로 Marking Line이 되어 있음(Drill Stopper 사용 시 유의)
- > Depth Gauge : 잔존골의 깊이와 멤브레인 거상 유무를 확인
- > Bone Condenser : 거상된 멤브레인 내부로 본을 밀어 넣음

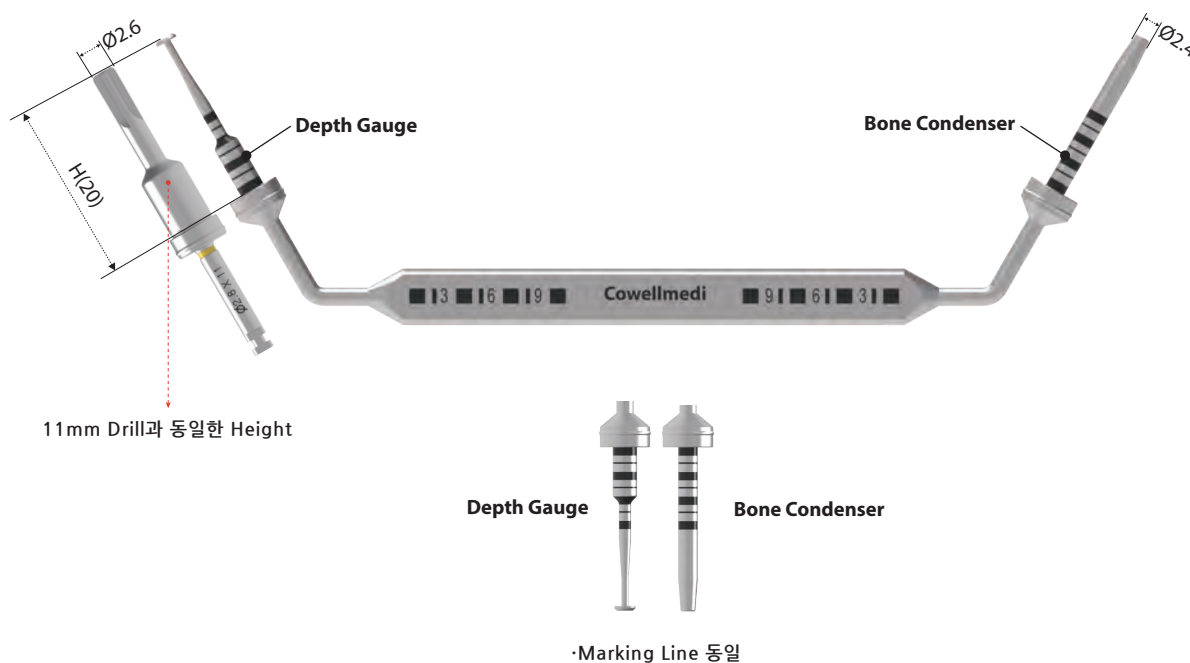

MF Controller + Stopper

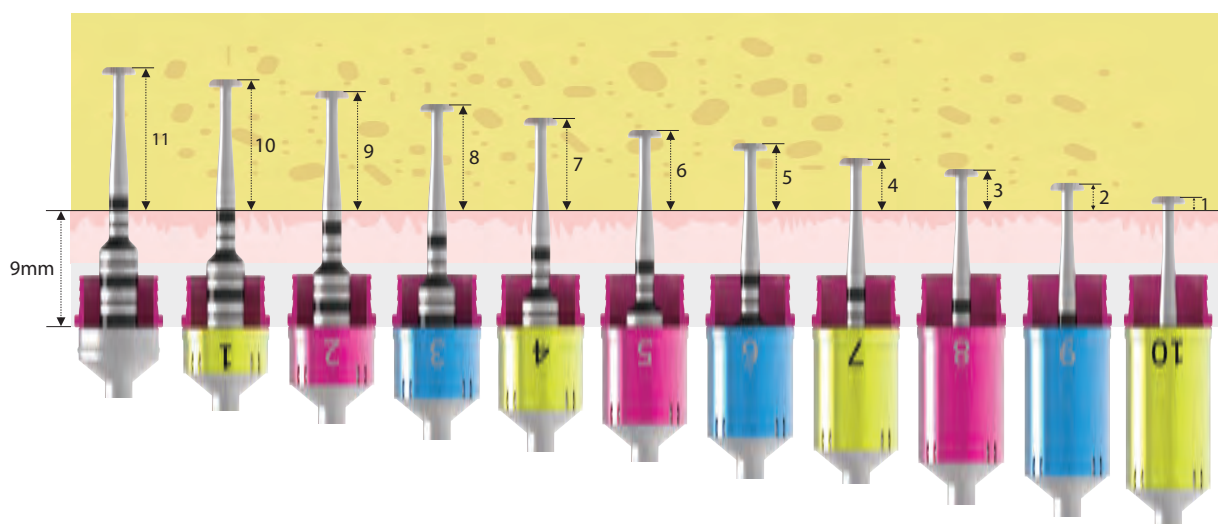

Implant Adapter *Extra*

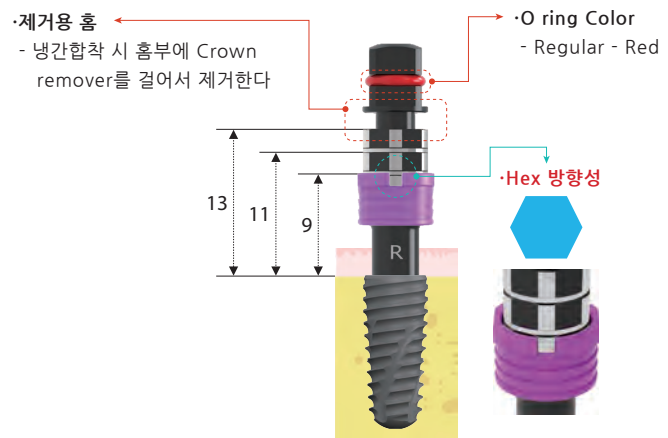
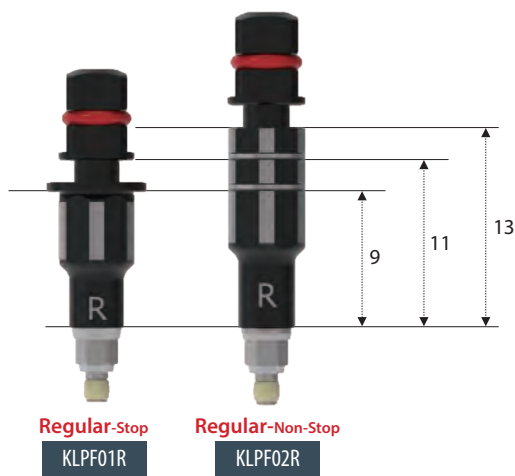

Adapter Extension *Extra*

> Implant Adapter의 길이가 짧아 사용하기 어려울 경우 연결하여 Ratchet, Machine으로 Fixture를 식립

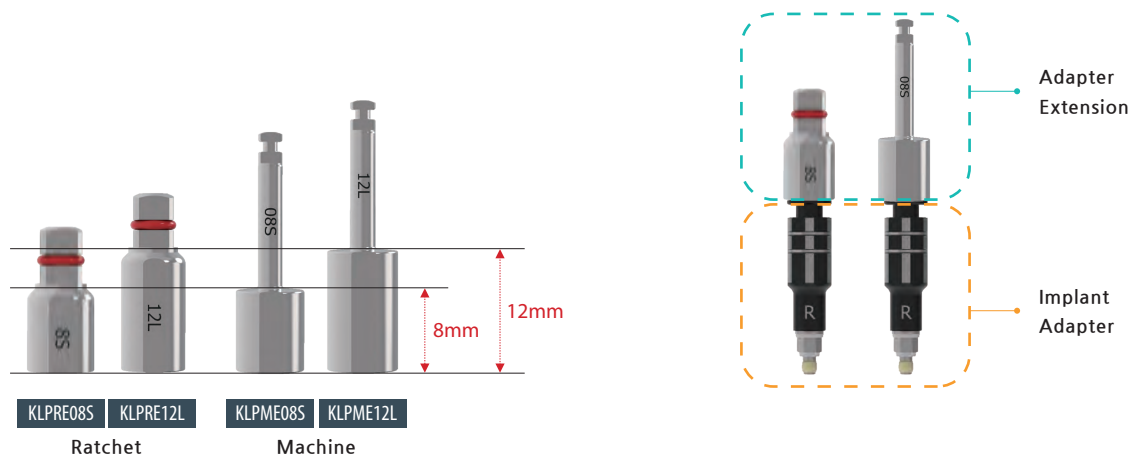

Sleeve *Extra*

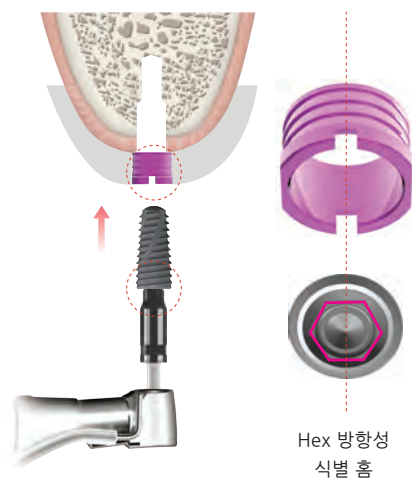
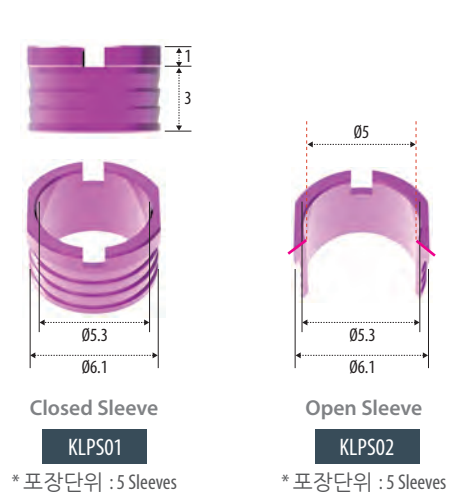

Bone Carrier

> 상악동막 거상 후 골이식재 주입 할 때에 사용



KSBC01

Guide Holder

> Aqua Lifter에 연결하여 사용



KSRGH01

Torque Wrench *Extra*

> Implant 식립 시 사용(Implant Connector에 연결)

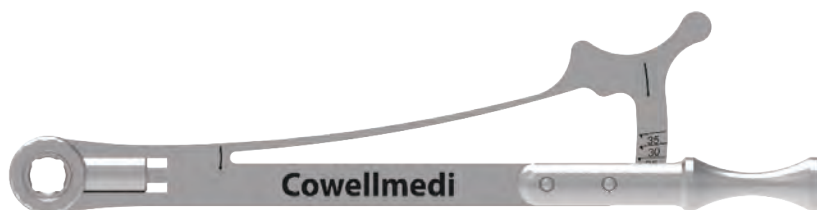

KTW001LP

Drill Protocol

> 잔존골 4mm, Fixture Ø4.0

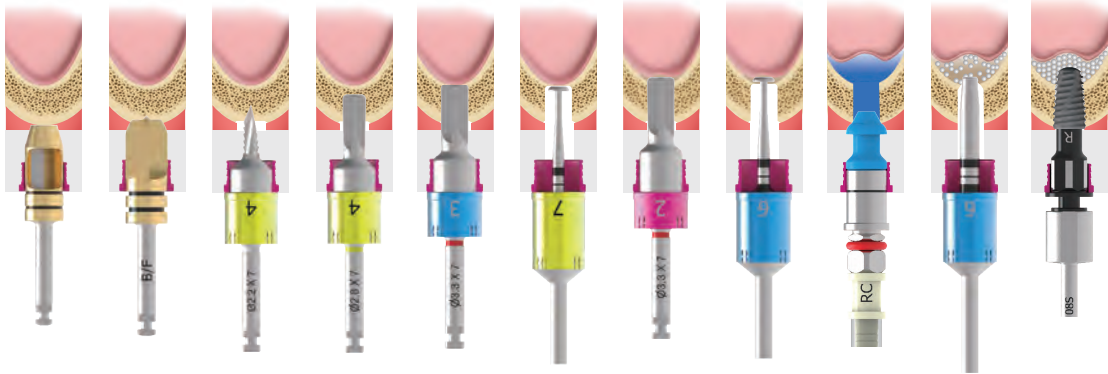

Bone Quality	Tissue Punch	Bone Flattening	Initial Drill (Ø2.2 X 7)	Crestal Drill	Crestal Drill	MF Controller	Crestal Drill	MF Controller	Aqua Lifter	MF Controller	Implant
Soft	▶	▶	▶	Ø2.8 X 7	Ø2.8 X 7	Depth	Ø2.8 X 7	Depth	▶	Condenser	▶
Normal	▶	▶	▶	Ø3.3 X 7	Ø3.3 X 7	Depth	Ø3.3 X 7	Depth	▶	Condenser	▶
Stopper			4	4	3	7	2	6		6	

Drill Protocol

> 잔존골 4mm, Fixture Ø4.5



Bone Quality	Tissue Punch	Bone Flattening	Initial Drill (Ø2.2 X 7)	Crestal Drill	Crestal Drill	Crestal Drill	MF Controller	Crestal Drill	MF Controller	Aqua Lifter	MF Controller	Implant
Soft	▶	▶	▶	Ø2.8 X 7	Ø3.3 X 7	Ø3.3 X 7	Depth	Ø3.3 X 7	Depth	▶	Condenser	▶
Normal	▶	▶	▶	Ø3.3 X 7	Ø3.3 X 7	Ø3.3 X 7	Depth	Ø3.3 X 7	Depth	▶	Condenser	▶
Stopper			4	4	4	3	7	2	6		6	

Drill Protocol

> 잔존골 4mm, Fixture Ø5.0

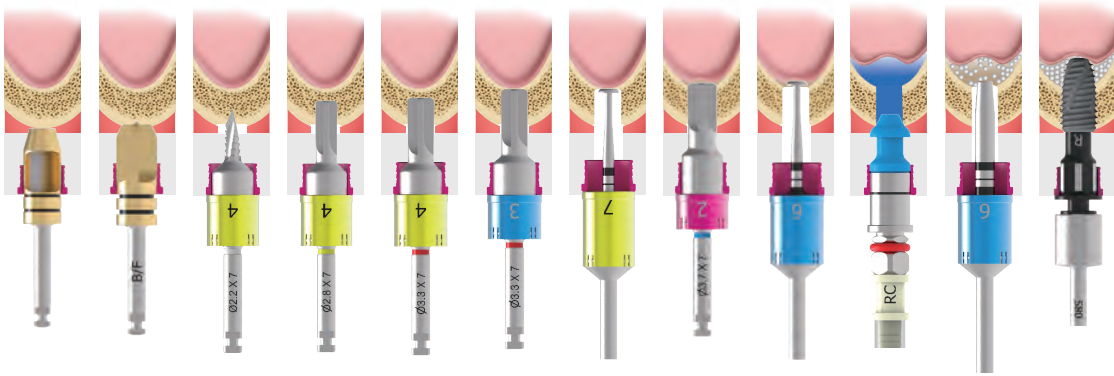

Bone Quality	Tissue Punch	Bone Flattening	Initial Drill (Ø2.2 X 7)	Crestal Drill	Crestal Drill	Crestal Drill	MF Controller	Crestal Drill	MF Controller	Aqua Lifter	MF Controller	Implant
Soft	▶	▶	▶	Ø2.8 X 7	Ø3.7 X 7	Ø3.7 X 7	Depth	Ø3.7 X 7	Depth	▶	Condenser	▶
Normal	▶	▶	▶	Ø3.3 X 7	Ø4.2 X 7	Ø4.2 X 7	Depth	Ø4.2 X 7	Depth	▶	Condenser	▶
Stopper			4	4	4	3	7	2	6		6	

Drill Protocol

> 잔존골 8mm, Fixture Ø4.0

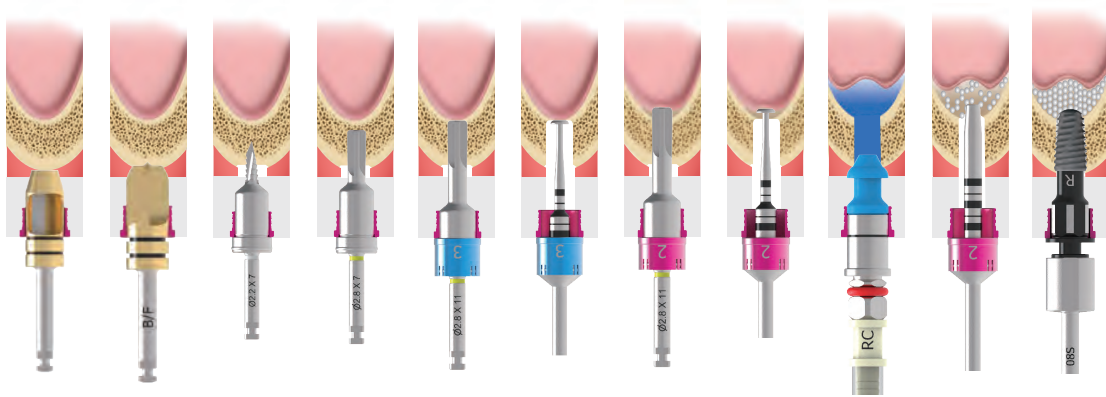

Bone Quality	Tissue Punch	Bone Flattening	Initial Drill (Ø2.2 X 7)	Crestal Drill	Crestal Drill	MF Controller	Crestal Drill	MF Controller	Aqua Lifter	MF Controller	Implant
Soft	▶	▶	▶	Ø2.8 X 7	Ø2.8 X 11	Depth	Ø2.8 X 11	Depth	▶	Condenser	▶
Normal	▶	▶	▶	Ø3.3 X 7	Ø3.3 X 11	Depth	Ø3.3 X 11	Depth	▶	Condenser	▶
Stopper					3	3	2	2		2	

Drill Protocol

> 잔존골 8mm, Fixture Ø4.5

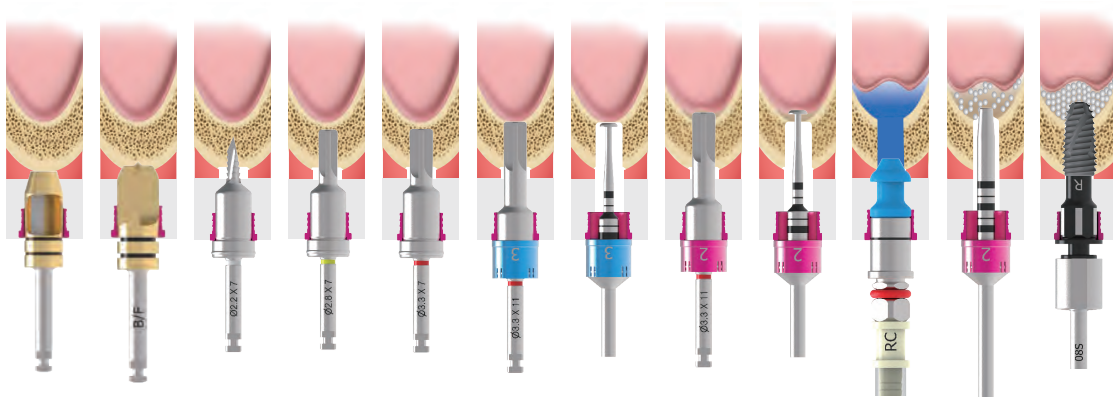

Bone Quality	Tissue Punch	Bone Flattening	Initial Drill (Ø2.2 X 7)	Crestal Drill	Crestal Drill	Crestal Drill	MF Controller	Crestal Drill	MF Controller	Aqua Lifter	MF Controller	Implant
Soft	▶	▶	▶	Ø2.8 X 7	Ø3.3 X 7	Ø3.3 X 11	Depth	Ø3.3 X 11	Depth	▶	Condenser	▶
Normal	▶	▶	▶	Ø3.3 X 7	Ø3.7 X 7	Ø3.7 X 11	Depth	Ø3.7 X 11	Depth	▶	Condenser	▶
Stopper						3	3	2	2		2	

Drill Protocol

> 잔존골 8mm, Fixture Ø5.0

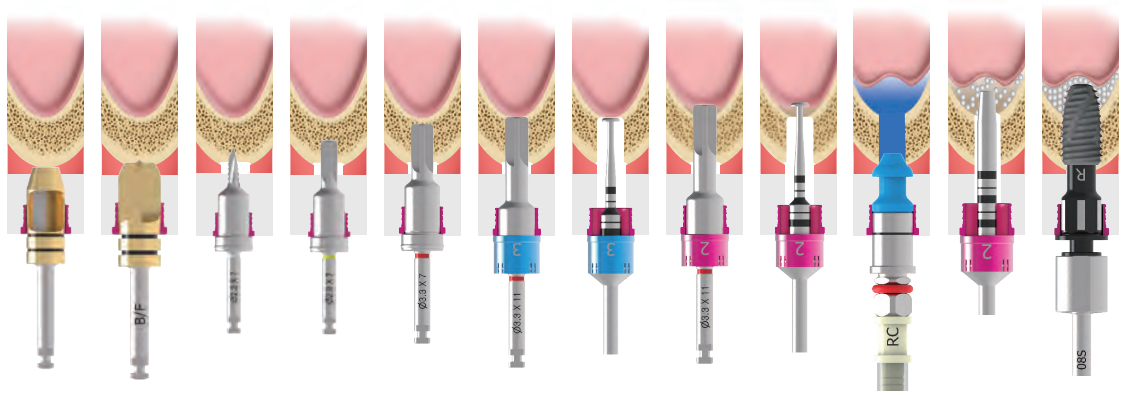

Bone Quality	Tissue Punch	Bone Flattening	Initial Drill (Ø2.2 X 7)	Crestal Drill	Crestal Drill	Crestal Drill	MF Controller	Crestal Drill	MF Controller	Aqua Lifter	MF Controller	Implant
Soft	▶	▶	▶	Ø2.8 X 7	Ø3.7 X 7	Ø3.7 X 11	Depth	Ø3.7 X 11	Depth	▶	Condenser	▶
Normal	▶	▶	▶	Ø3.3 X 7	Ø4.2 X 7	Ø4.2 X 11	Depth	Ø4.2 X 11	Depth	▶	Condenser	▶
Stopper						3	3	2	2		2	

Drill Protocol - Spreader

> 잔존골 4mm, Fixture Ø4.0, Ø4.5

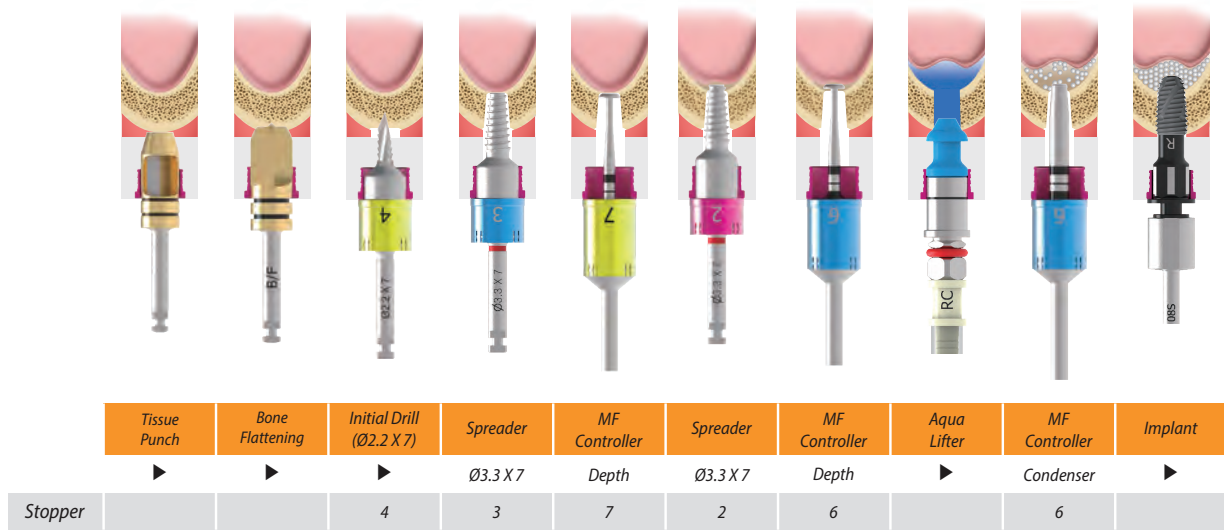

Drill Protocol - Spreader

> 잔존골 4mm, Fixture Ø5.0

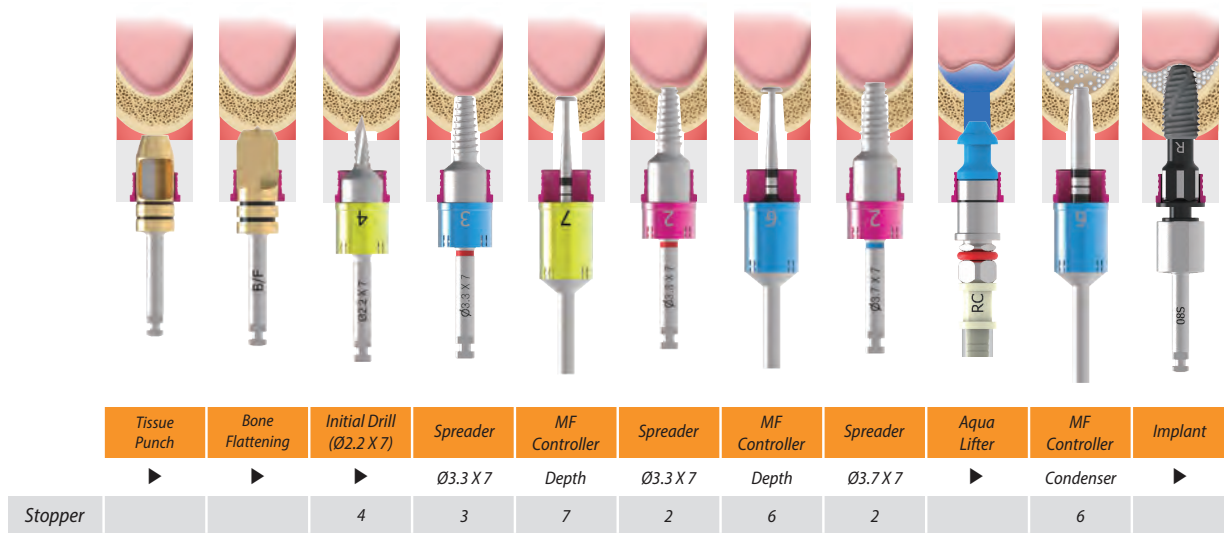

Drill Protocol - Spreader

> 잔존골 8mm, Fixture Ø4.0, Ø4.5

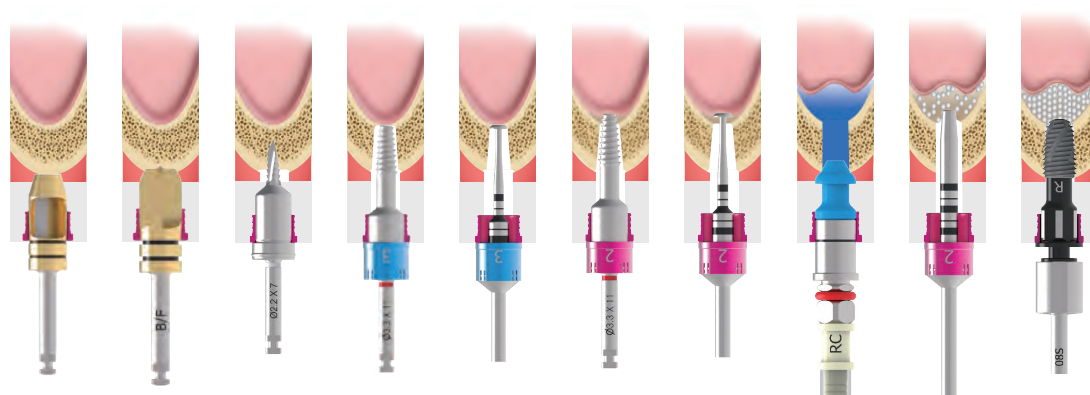

	Tissue Punch	Bone Flattening	Initial Drill (Ø2.2 X 7)	Spreader	MF Controller	Spreader	MF Controller	Aqua Lifter	MF Controller	Implant
	▶	▶	▶	Ø3.3 X 11	Depth	Ø3.3 X 11	Depth	▶	Condenser	▶
Stopper				3	3	2	2		2	

Drill Protocol - Spreader

> 잔존골 8mm, Fixture Ø5.0

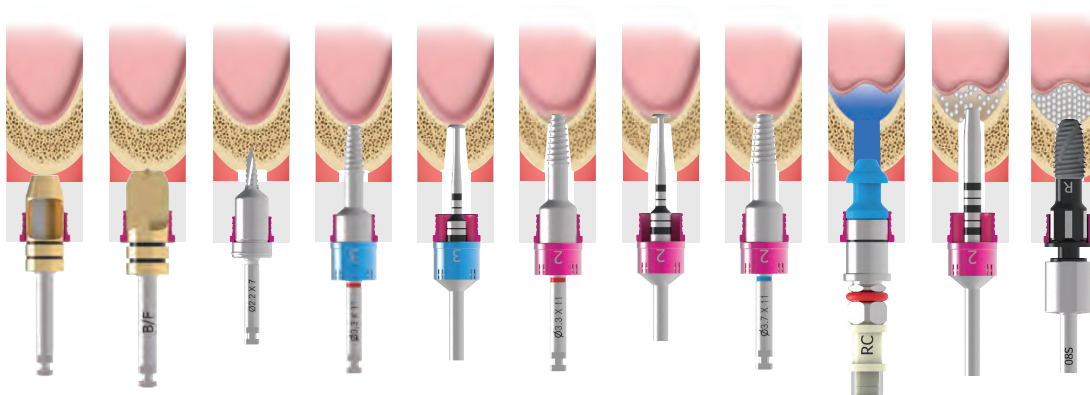

	Tissue Punch	Bone Flattening	Initial Drill (Ø2.2 X 7)	Spreader	MF Controller	Spreader	MF Controller	Spreader	Aqua Lifter	MF Controller	Implant
	▶	▶	▶	Ø3.3 X 11	Depth	Ø3.3 X 11	Depth	Ø3.7 X 11	▶	Condenser	▶
Stopper				3	3	2	2	2		2	

MFS KIT [KSA004]

> 모든 상악동 거상술을 하나의 Kit로 해결 (Crestal & Lateral Approach Technique)

Crestal Drill Stopper

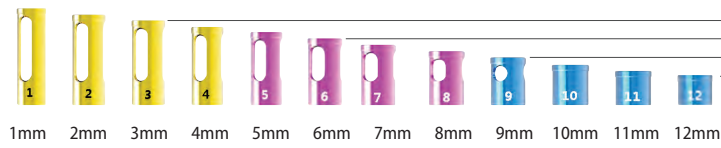

Point Ø2.2 Crestal Drill

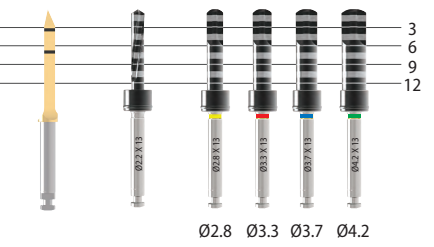

Aqua Lifter



Guide Holder

Bone Condenser

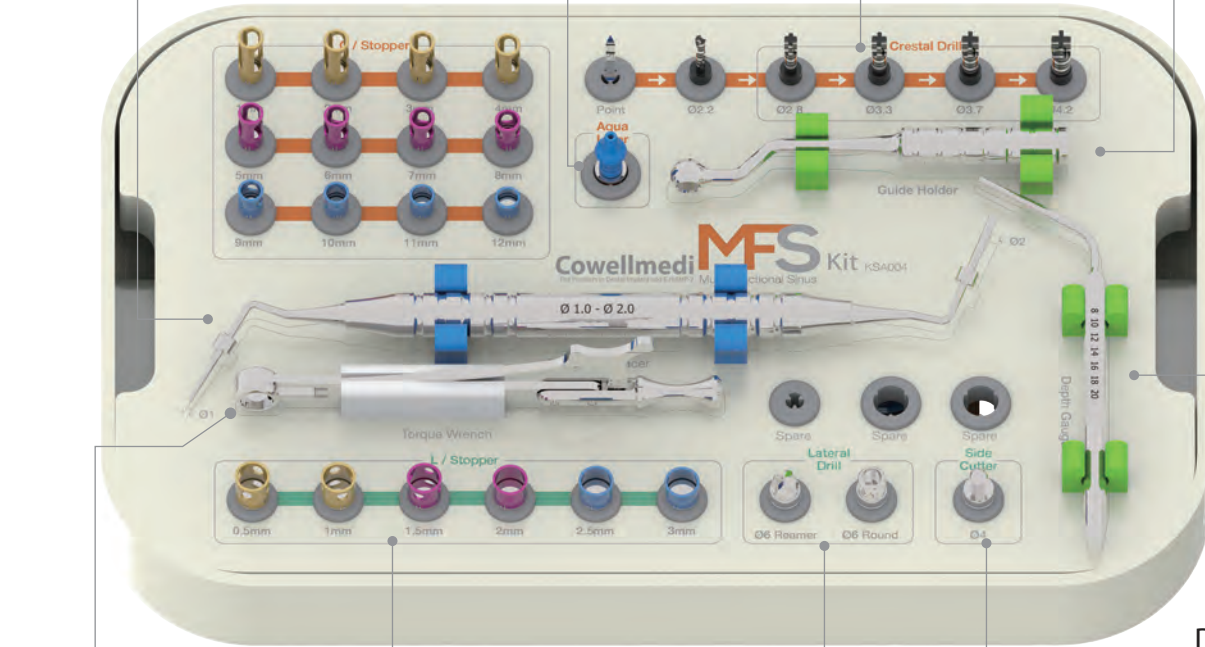

Torque Wrench

Lateral Stopper

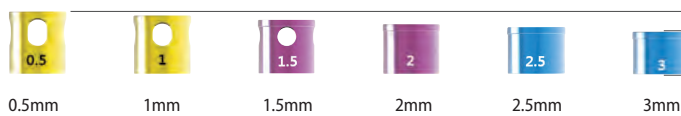

Lateral Drill

Side Cutter

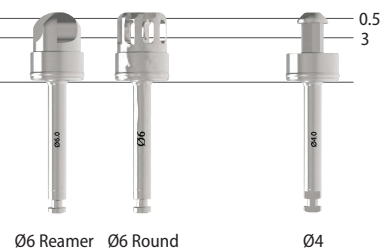

Depth Gauge

Aqua Ratchet Connector



Aqua Syringe Connector



Aqua Tube



Bone Carrier

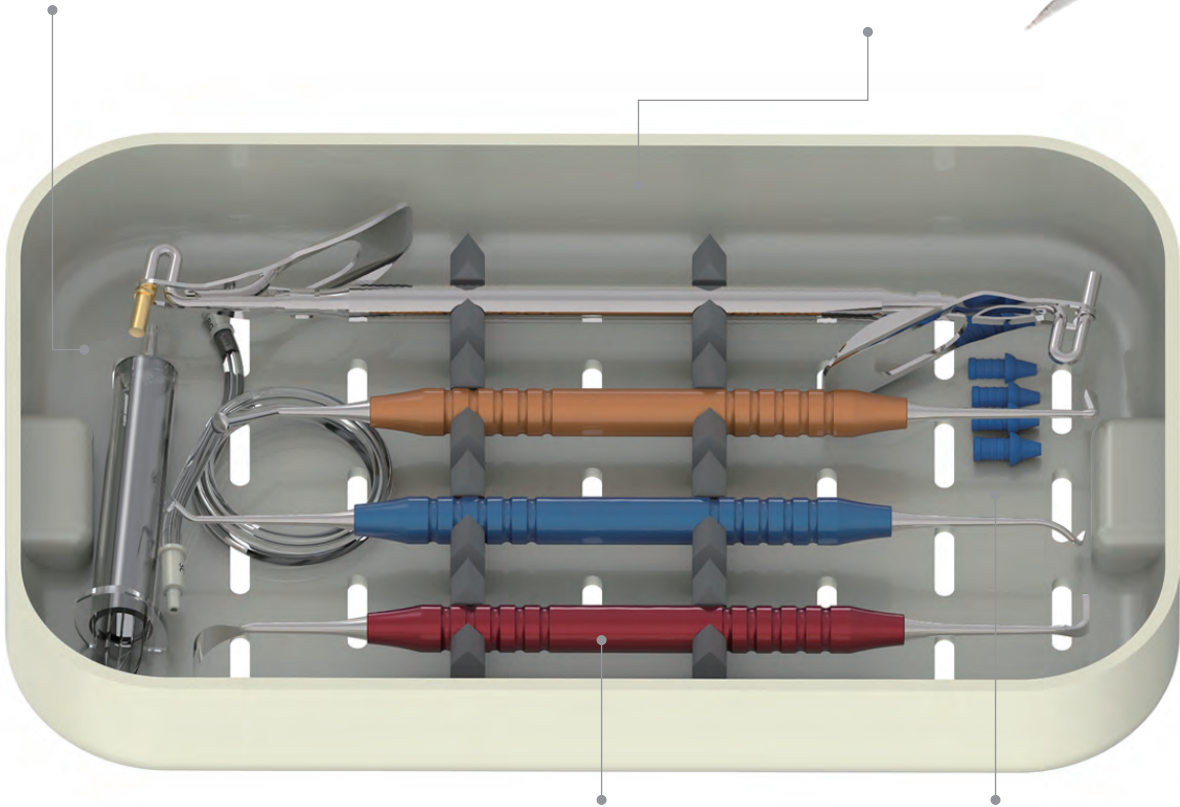

Sinus Elevator

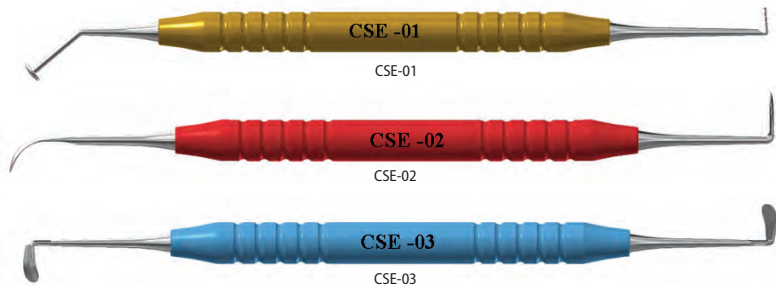

Aqua Lifter Silicon



Crestal Approach - Components

1. Point Drill 800~1,000rpm

- > Cortical bone에 천공 위치 선정
- > 잔존골 높이가 3.5mm 이하로 낮을 경우 Drilling 주의



Code KPD01S

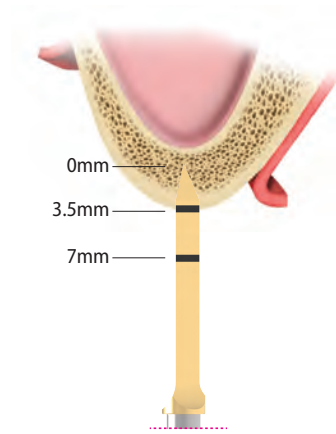

2. 2.2 Twist Drill 800~1,000rpm

- > Crestal Drill 사용 전, guide hole 형성
- > 잔존골 높이를 고려하여 Drill Stopper 사용



Code KSTD22

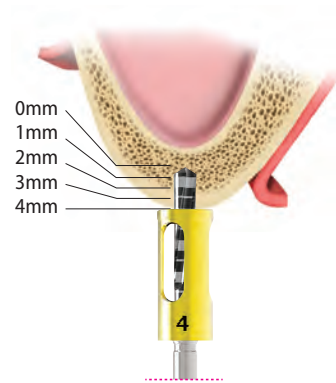

3. Crestal Drill 400~800rpm

- > 식립될 Fixture 직경에 따라 순차적으로 사용
- > Sinus 바닥이 Flat, Incline, Septum인 경우에도 사용 가능
- > 골질에 따라 50회 사용 가능

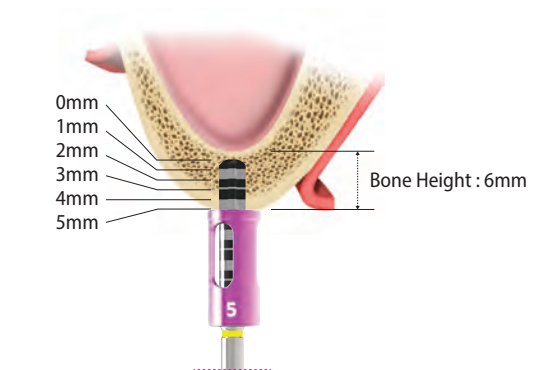

Fixture Dia.	Ø3.3	Ø3.5	Ø4.0	Ø4.5 / Ø5.0
Diameter	Ø2.8	Ø3.3	Ø3.7	Ø4.2
	KSCD28	KSCD33	KSCD37	KSCD42

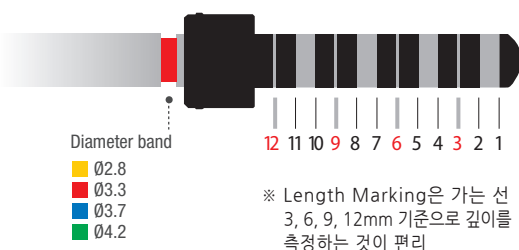

※ 편평한 바닥날이 membrane과의 접촉 시 손상을 최소화

4. Crestal Drill Stopper

- > CT로 측정된 상악동 하연골 높이와 동일한 길이로 천공되도록 Stopper 체결
- > CT 측정을 하지 않았다면, 한 단계 낮은 Stopper를 체결 후 순차적으로 길이를 늘려나가며 천공

Drilling Depth	1mm	2mm	3mm	4mm	5mm	6mm
	KSDS01	KSDS02	KSDS03	KSDS04	KSDS05	KSDS06
Drilling Depth	7mm	8mm	9mm	10mm	11mm	12mm
	KSDS07	KSDS08	KSDS09	KSDS10	KSDS11	KSDS12

5. Depth Gauge

- > 상악동 하연골의 천공을 확인한 후 잔존골 두께 측정 (완전히 개통되지 않도록 하며 입구쪽만 개통)
- > 잔존골의 두께 기준으로 Stopper를 체결하여 상악동 하연골과 Membrane을 분리

Code KDG001S



6. Aqua Membrane Lifter System

- > 상악동 하연골의 거상이 제대로 되었는지 확인 후 Aqua Membrane Lifter System을 이용하여 Membrane을 거상

- ① Aqua Lifter를 Guide Holder와 체결
- ② Aqua Syringe Connector (SC)를 이용하여 syringe에 Aqua Tube 연결
- ③ Syringe에 사용하고자 하는 골이식재 양만큼 생리식염수 주입
- ④ Aqua Ratchet Connector (RC)를 이용하여 Aqua Lifter Drill에 Tube 연결
- ⑤ 생리식염수 주입

Aqua Lifter Code KSAL02

Aqua Lifter Silicon Code KSALS01

Aqua Ratchet Connector Code KSAL01RC

Aqua Syringe Connector Code KSAL01SC

Aqua Tube Code KSALT030

⑤ 식염수 주입으로 Sinus Membrane 거상 (0.1cc 주입 -> 거상 높이 1mm)
 ※ 0.2 ~ 0.5cc 가량 주입 후 압력이 가해지기 시작하면 주입량과 거상 높이 측정

① Aqua Lifter, Guide Holder

④ Aqua Ratchet Connector

③ Syringe

② Aqua Syringe Connector

※ 거상 후, 주입된 생리식염수와 혈액이 섞여 주사기 내로 Aspiration

Guide Holder Code KSRGH01

7. Torque Wrench

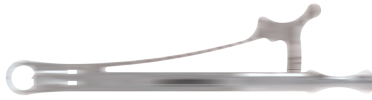

> Fixture를 식립 할 때와 Fixture에 보철 부속을 연결할 때 수동으로 회전력을 제어

Code KTW001



8. Bone Carrier

> 골이식재 주입할 때에 사용



Code KSBC01

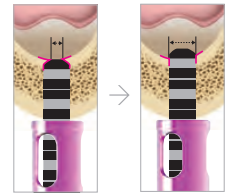

※ 필요 시 입구 확장을 위해 Crestal Drill로 1mm 더 깊게 Drilling

9. Bone Condenser

> Bone Condenser에 Stopper를 장착 후 상악동 내부까지 골이식재 밀어 올림
> 상악동 내부에 넣어 회전시켜 골이식재가 골고루 분산 (Depth Gauge로도 가능)



Code KSBC1022

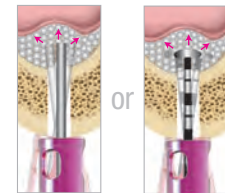

※ 필요 시 상악동 내부의 골이식재를 골고루 분산 (Depth Gauge로도 가능)

10. Implant Drill (Final)

> Crestal Drill 사용시 보다 1-2mm 더 깊게 Drilling

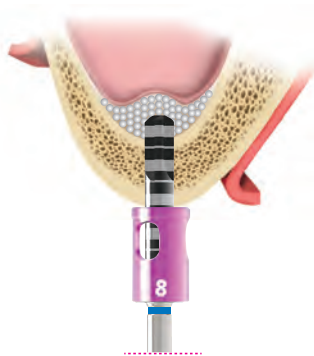

11. Implant Placement

> 초기 고정력 확보를 위해 잔존골이 3mm 이하일 경우 Implant 식립은 하지 않고 상악동 골이식술만 시행



Crestal Approach - Drilling Sequence

> Implant 식립 시 Ø4.0 이상 식립 권장

1. Ø3.3 Narrow Fixture

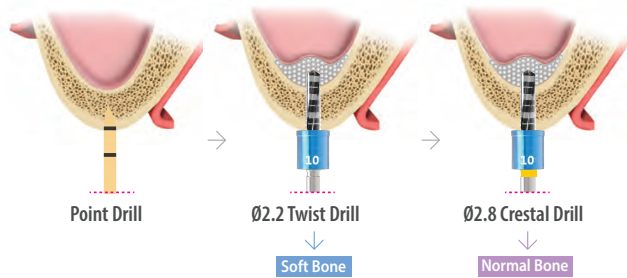

2. Ø3.5 Fixture

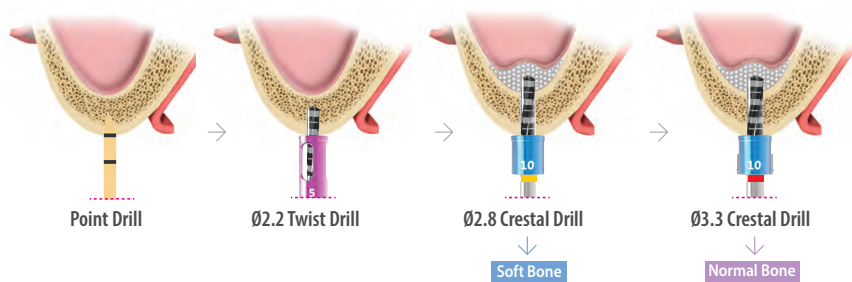

3. Ø4.0 Fixture



4. Ø4.5 Fixture

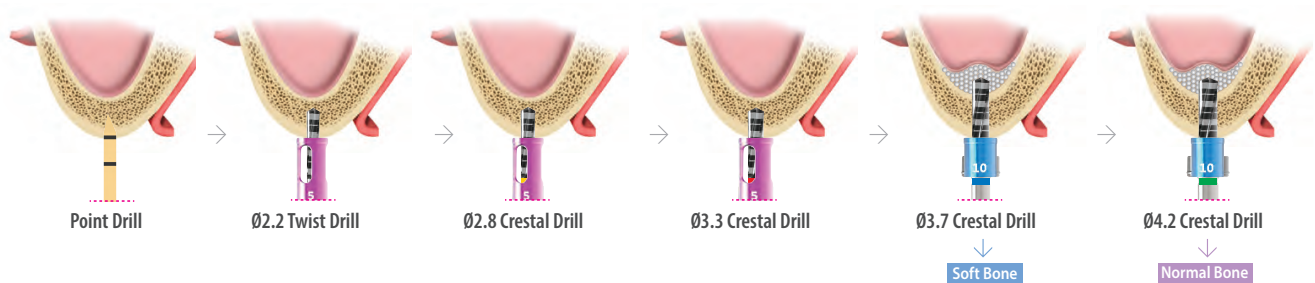

※ Ø5.0 Fixture Normal Bone 이상은 식립 전 최종적으로 전용 Final Drill 필요

※ 식립 임플란트 보다 한 단계 짧은 Drill 사용 (Ex. 10mm 임플란트 식립 시, 8~9mm Drill)

Lateral Approach - Components

1. Ø6 Lateral Reamer 800~1,000rpm

> 골의 높이에 따라 Stopper를 체결 후 Drilling (둥근 형상)



Code	KSLD60
------	--------

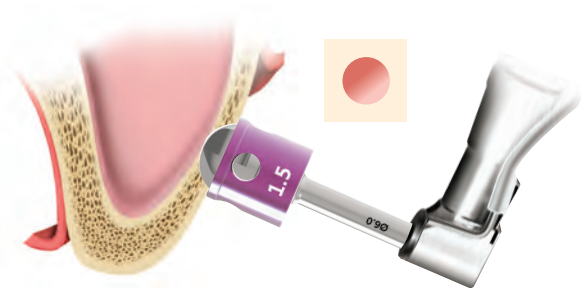

2. Ø6 Lateral Round Drill 800~1,000rpm

> 골의 높이에 따라 Stopper를 체결 후 Drilling (둥근 형상 가장자리)
> Drilling 후 남은 잔존골은 상악동 거상 완료 후 원래 자리에 위치



Code	KSLRD60
------	---------

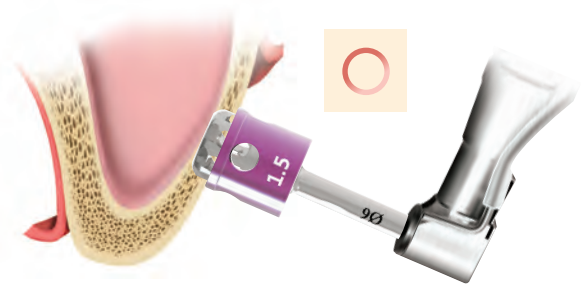

3. Lateral Stopper

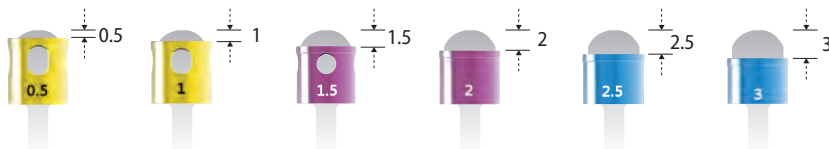

Drilling Depth	0.5mm	1mm	1.5mm	2mm	2.5mm	3mm
	KSDSL05	KSDSL10	KSDSL15	KSDSL20	KSDSL25	KSDSL30

4. Sinus Elevator

> CSE-01 : Sinus Membrane 초기 거상



Code	KSSE01
------	--------

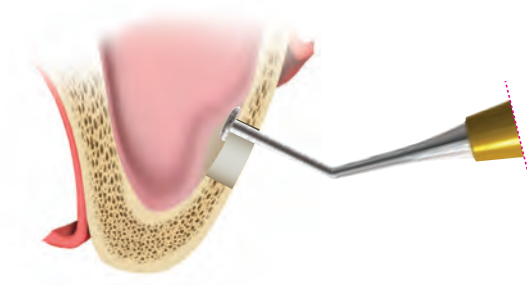

> CSE-02 : CSE-01을 사용 후 단계적 Sinus Membrane 거상



Code	KSSE02
------	--------

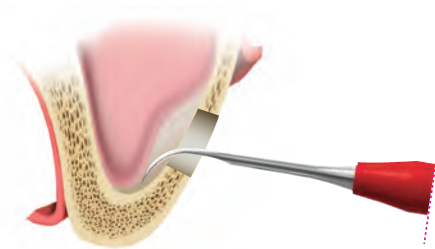

> CSE-03 : CSE-02을 사용 후 단계적 Sinus Membrane 거상



Code	KSSE03
------	--------

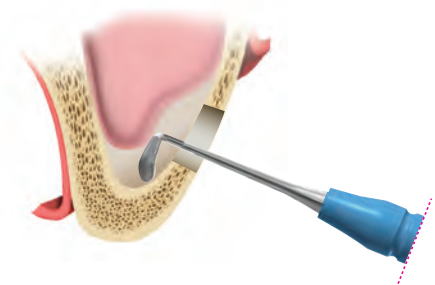

5. Ø4 Side Cutter 800~1,000rpm

> Window를 확장하고자 할 때 Stopper 체결 후 사용



Code	KSC60
------	-------

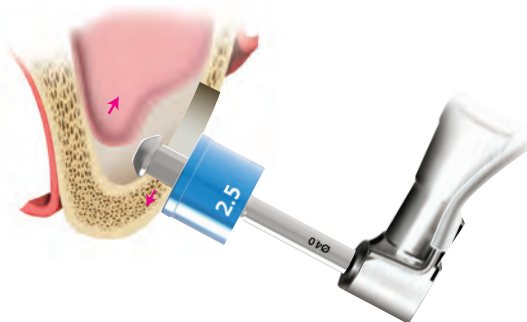

6. Sinus Bone Graft

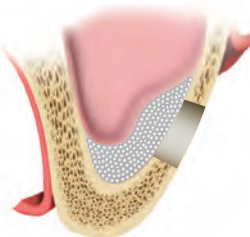

7. Implant Drill (Final)



8. Implant Placement

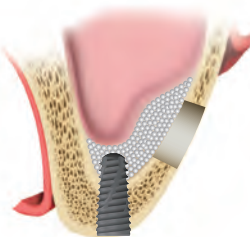

Easy Sinus Lift Kit [KSA001]

> Tap Drill을 이용하여 Sinus Lift와 Ridge Split을 할 수 있는 간편한 Kit

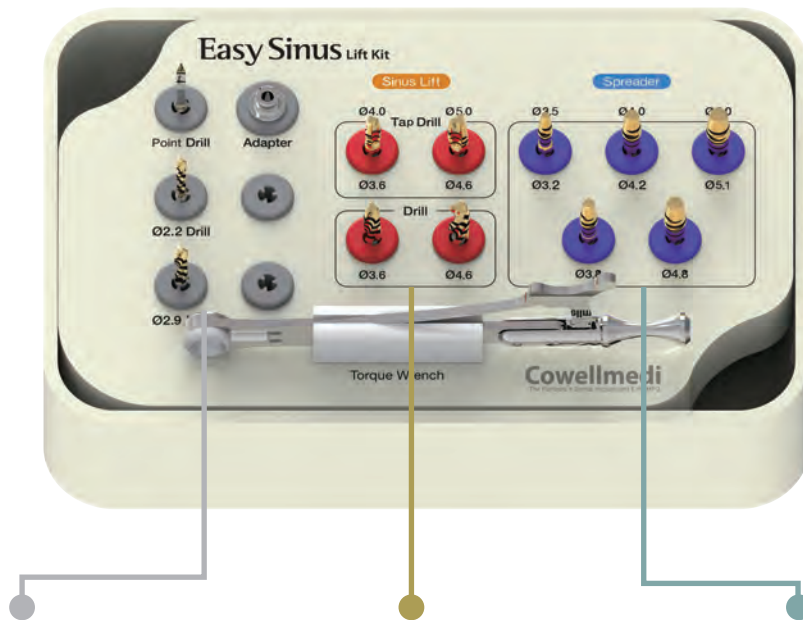

공통으로 사용되는 Tool

> Sinus Lift나 Ridge Split 시 골질에 따라 슬자의 판단에 의해 선택 사용

Drill Speed : 800-2,000 rpm

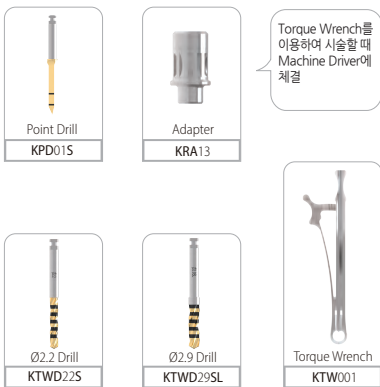

Torque Wrench를 이용하여 시술할 때 Machine Driver에 체결

Sinus Lift

> 상악동 아래 소구치부에 사용되며, Sinus Window OP에 비해 간편한 시술 가능
> 저속으로 회전하는 Tap Drill에 의해 안전하게 Sinus를 Elevation

Drill Speed : 20-30 rpm
Torque : 45 N.cm

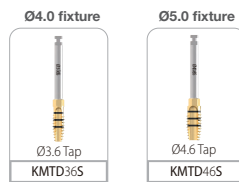

Drill Speed : 100-500 rpm
Torque : 45 N.cm

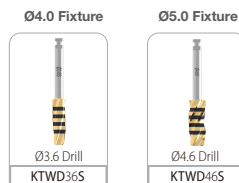

Spreader

> 단계적으로 안전하게 Ridge Split을 실시
> Condensing, Spreader 등의 기능을 하는 다목적 Tool

Drill Speed : 20-30 rpm
Torque : 45 N.cm

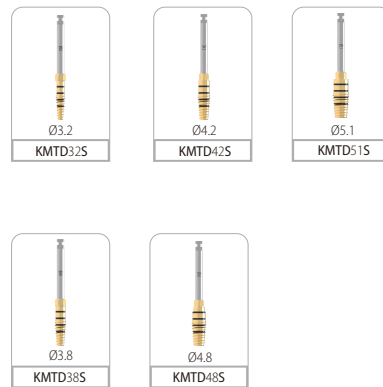

Sinus Lift

• Tap Drill (Ø3.6, Ø4.6)

- > 상악동 측 Cortical Bone을 뚫음과 동시에 Sinus Membrane을 손상 없이 서서히 올리고 Bone Graft 후 Fixture를 식립
- > 20 ~ 30 rpm 사용 / 45Ncm



Diameter	Ø3.6	Ø4.6
	KMTD36S	KMTD46S

Ratchet Adapter를 사용하여 Torque Wrench와 함께 사용 가능

10
8
6
4

골질이 단단하거나, 잔존골과의 부하가 걸릴 때, 근단부의 절삭날이 천천히 절삭하면서 Lift할 수 있도록 함
상악동의 Membrane 손상 없이 Cortical Bone을 뚫음

탄성 손잡이를 손가락으로 눌러 회전력을 제어

• Twist Drill (Ø3.6, Ø4.6)

- > Tap Drill 후 Fixture를 식립할 때 D2 이상의 골을 위한 Drill. 필요시 나사산을 제거하여 Hole의 크기를 넓혀 줌으로써 Bone Graft를 용이하게 함.
- > 100 ~ 500 rpm 사용 / 45Ncm



Diameter	Ø3.6	Ø4.6
	KTWD36S	KTWD46S



• Spreader (Ø3.2, Ø3.8, Ø4.2, Ø4.8, Ø5.1)

- > 상악동 거상술 및 치조골 확장술시 spread 할 수 있음
- > 20 ~ 30 rpm 사용 / 45Ncm

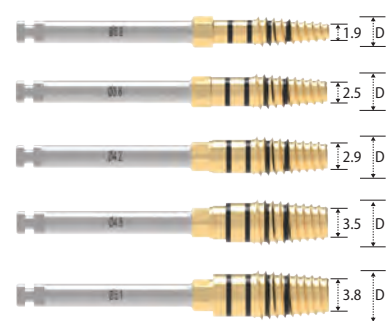

Diameter	Ø3.2	Ø3.8	Ø4.2	Ø4.8	Ø5.1
	KMTD32S	KMTD38S	KMTD42S	KMTD48S	KMTD51S

12
10
8
6
4

골질이 단단하거나, 잔존골과의 부하가 걸릴 때, 근단부의 절삭날이 천천히 절삭하면서 Spread할 수 있도록 함

• Adapter

- > Torque Wrench를 이용하여 시술할 때 Machine Driver에 체결



KRA13



Sequence - Sinus Lift

· Sinus Lift Drill만 사용

1 Sinus Lift (Ø4.0 Fixture)

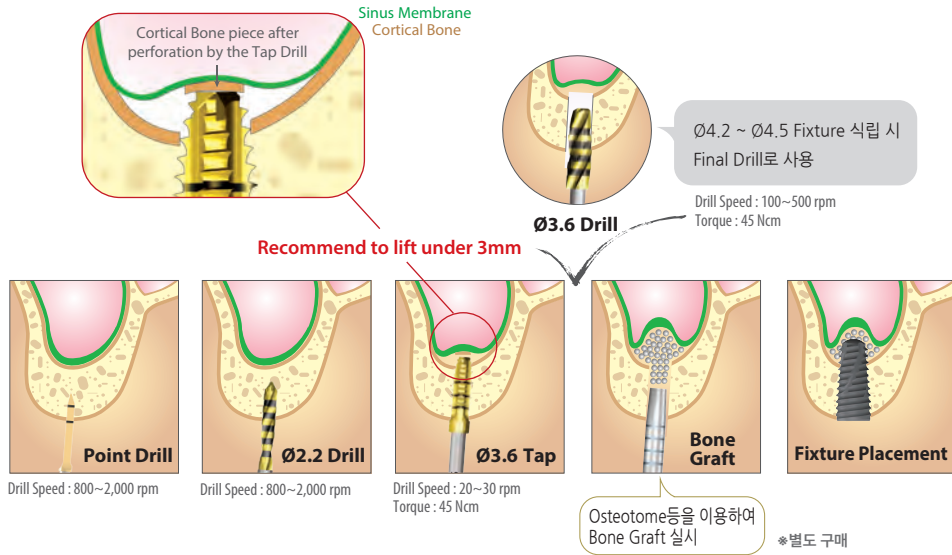

▶ 즉시 식립과 Tap Drill를 활용한 상악동 거상술 (Ø4.0 Fixture)

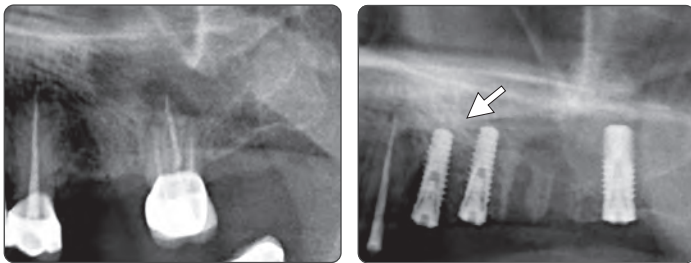

2 Sinus Lift (Ø5.0 Fixture)

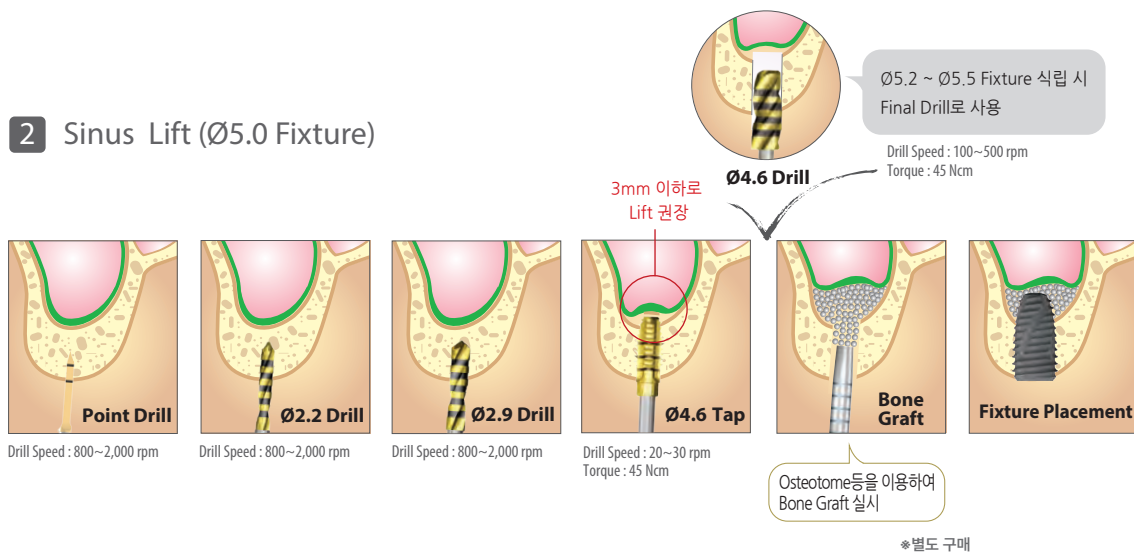

▶ 즉시 식립과 Tap Drill를 활용한 상악동 거상술 (Ø5.0 Fixture)

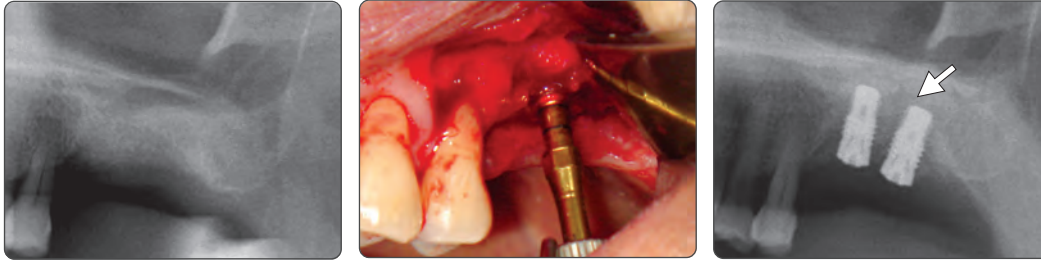

• Sinus Lift Drill과 Spreader Drill을 함께 사용

Sinus Lift (Ø4.0 Fixture)

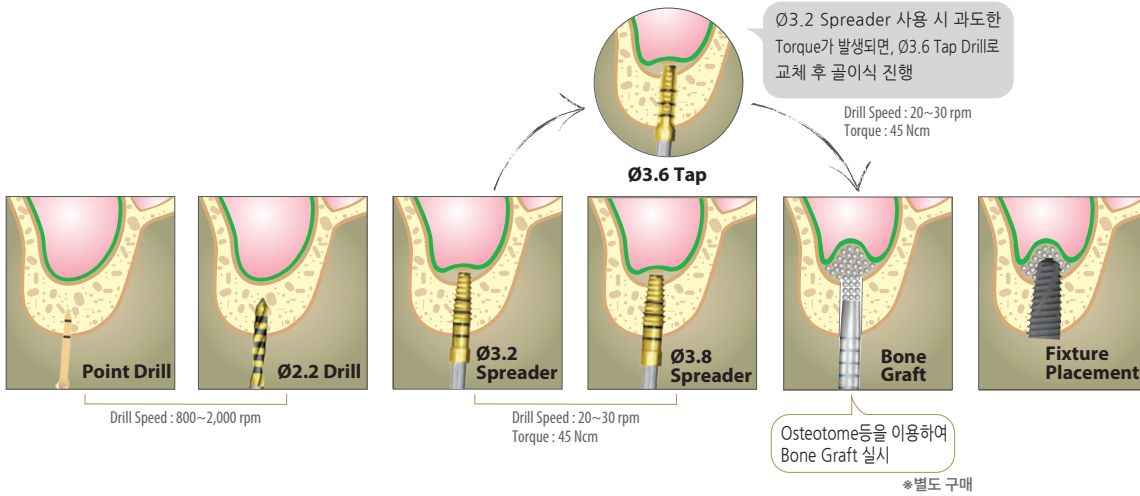

Sinus Lift (Ø5.0 Fixture)

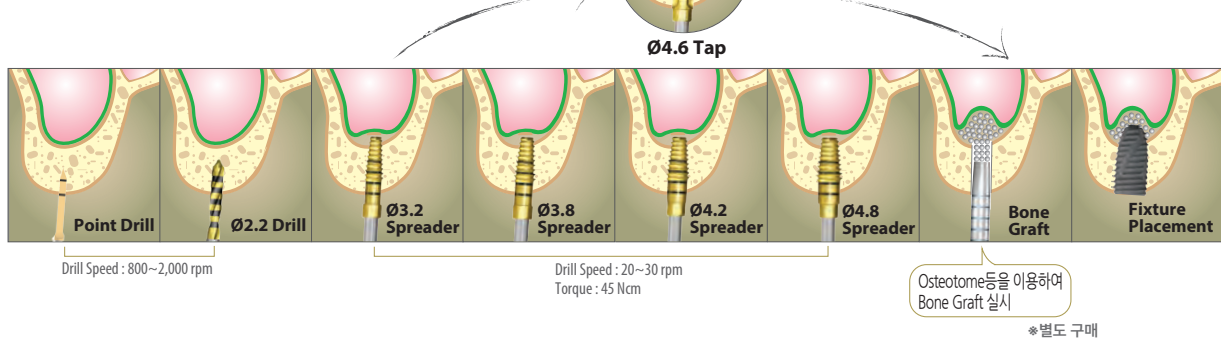

Note

- > 상악동 거상술 시 Sinus Lift Drill과 Spreader Drill을 함께 사용하는 술식을 권장
- > D2에 Fixture를 식립하기 전에 Final Drill을 사용하여 주변 치조골을 지나치게 압박하지 않도록 주의

ex) Ø4.0 Fixture 식립

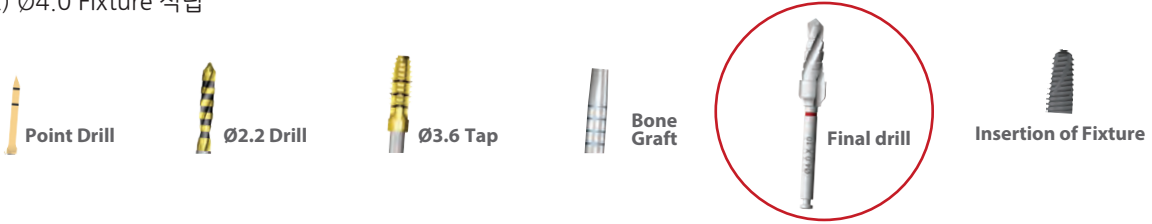

Sequence - Spreader

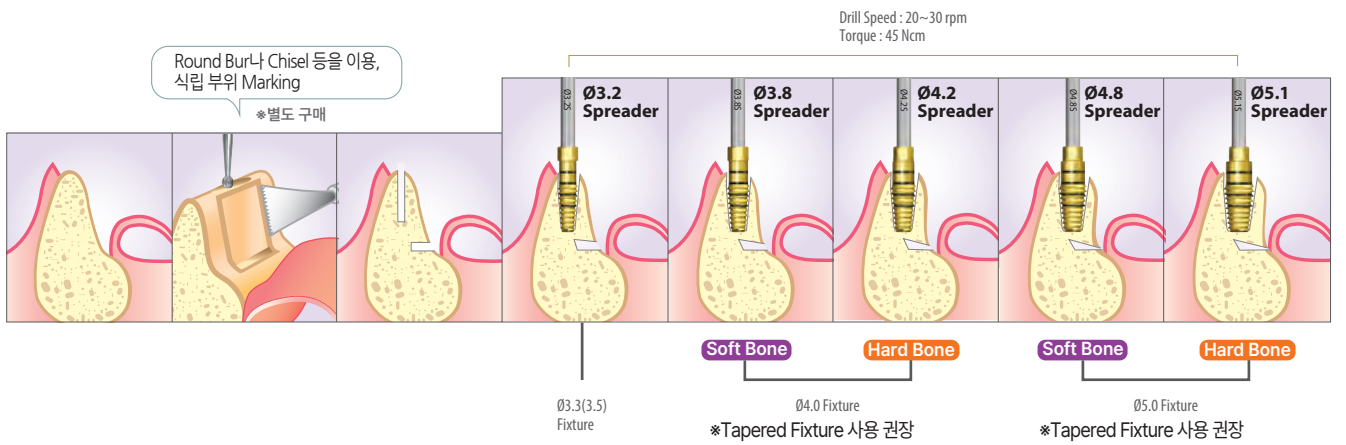

Spreader Drill를 활용한 Ridge Split 및 Block Bone 증대술 (Ø4.0 Fixture)

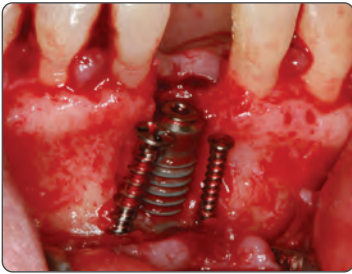
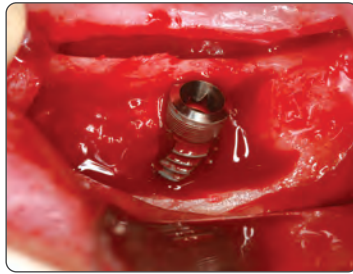
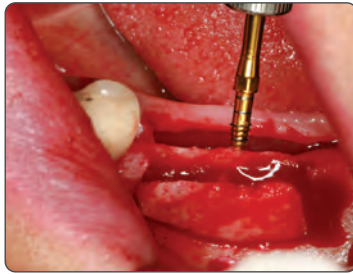
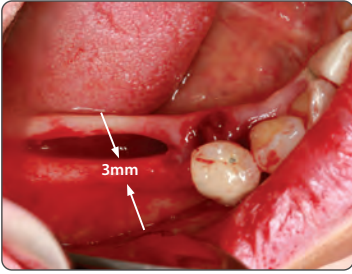

Multi-Functional Removal Kit

MFR KIT [KHA001]

> 파절된 Fixture / Screw / Abutment의 손쉬운 제거

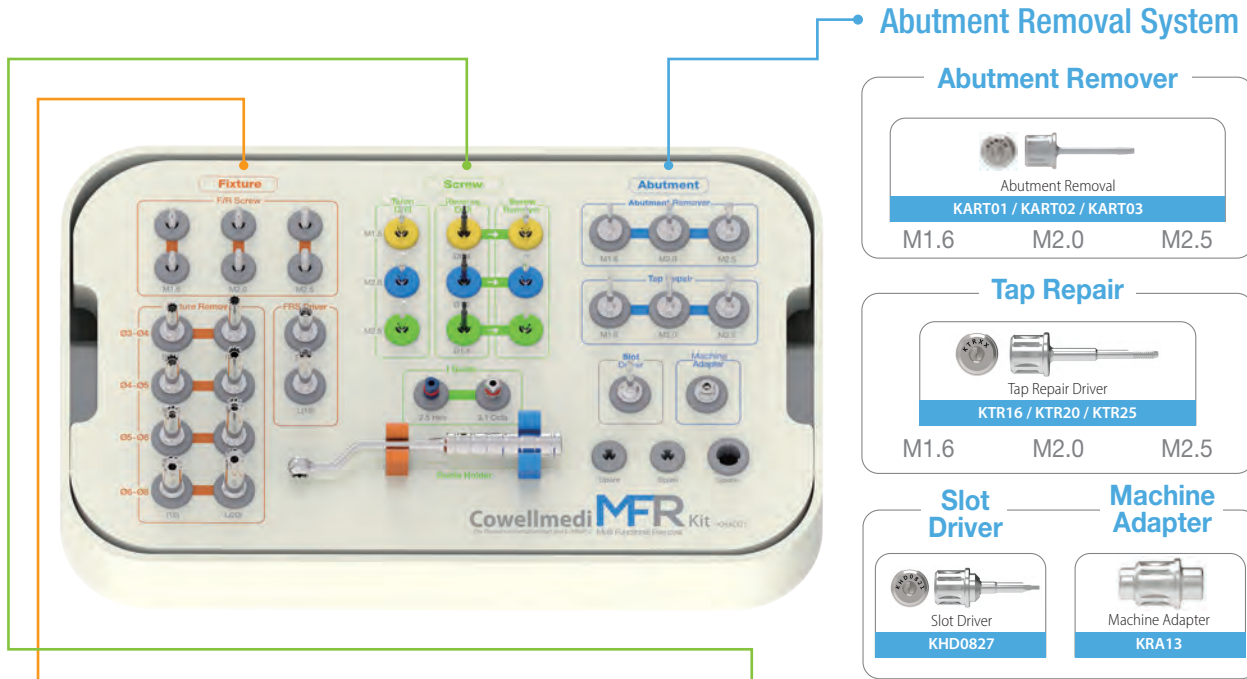

Abutment Removal System

Abutment Remover

Abutment Removal
KART01 / KART02 / KART03

M1.6 M2.0 M2.5

Tap Repair

Tap Repair Driver
KTR16 / KTR20 / KTR25

M1.6 M2.0 M2.5

Slot Driver **Machine Adapter**

Slot Driver Machine Adapter
KHD0827 KRA13

Fixture Removal System

F/R Screw

Fixture Removal Screw Fixture Removal Screw Fixture Removal Screw
KFRS16 KFRS20 KFRS25

M1.6 M2.0 M2.5

Fixture Remover

03~04 Fixture Removal
KFR3515 / KFR3520

04~05 Fixture Removal
KFR4015 / KFR4020

05~06 Fixture Removal
KFR5015 / KFR5020

06~08 Fixture Removal
KFR6015 / KFR6020

FRS Driver

Fixture Removal
KFRSD13 / KFRSD18

Torque Wrench
KTW002

Screw Removal System

Talon Drill **Reverse Drill** **Screw Remover**

M1.6 M2.0 M2.5

Talon Drill (Claw Drill) Reverse Guide Drill Screw Remover

KSRC08 KSRGD08 KRSR08
KSRC12 KSRGD12 KRSR12
KSRC14 KSRGD14 KRSR14

I Guide

I Guide (Sub. 2.5 Hex) I Guide (Int. 3.1 Octa)

KSRI25H KSRI31O

*Red Silicon O-Ring KSRI001

Guide Holder KSRGH01

MFR Kit - Components

1. Fixture Removal System

- ① F/R Screw와 FRS Driver 체결.
- ② F/R Screw 장착 후 FRS Driver를 Fixture와 연결 (시계방향으로 40 ~ 60Ncm) 후 FRS Driver 제거
- ③ Fixture Remover와 F/R Screw 체결 (반시계방향)
- ④ Torque Wrench에 체결 후 Fixture 제거 (반시계방향, 100~400Ncm)
- ⑤ 제거된 Fixture를 Vise 등으로 고정하여 Torque Wrench를 체결하여 Fixture Remover 분리 (시계방향)
- ⑥ F/R Screw에 FRS Driver를 체결 후 Torque Wrench를 사용하여 F/R Screw 분리 (반시계방향)

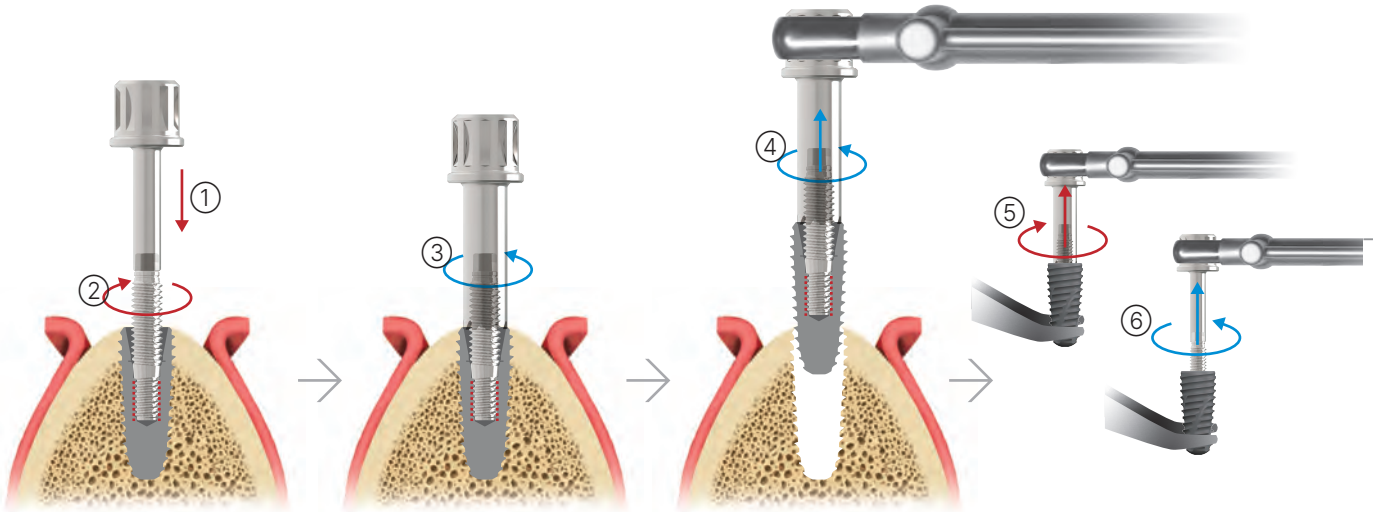

- ※ F/R Screw는 1회 사용 권장(100Ncm 이상일 경우 구부러지거나 파절 위험) 단, 100Ncm 이하일 경우 2회 사용 가능
- ※ Fixture 제거 시 충분한 irrigation 필요
- ※ 최대 Torque를 초과하는 경우 Fixture가 구부러지거나 파절 위험
- ※ 최대 Torque로도 Fixture가 제거되지 않을 시 Fixture Remover와 F/R Screw 분리, Fixture 주위 Bone을 Round Bur등으로 삭제한 후 제거 재시도

2. Screw Removal System

Talon Drill

- ① Screw가 Fixture 내부에서 파절 (파절된 Screw Size 확인 필요)
- ② Fixture Connection에 맞는 I Guide를 Guide Holder에 장착 후 Fixture에 체결
- ③ I Guide Hole 안으로 Talon Drill 삽입
- ④ 누르는 힘으로 Screw 제거 (반시계방향, 60~80rpm)

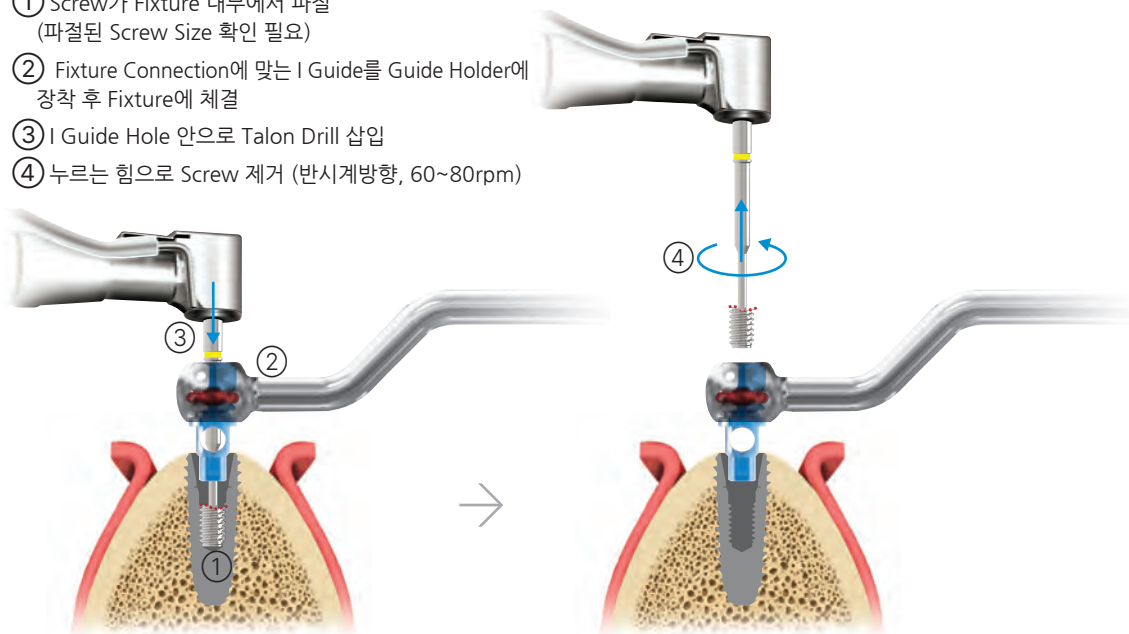

- ※ I Guide 와 Fixture가 정확하게 체결이 되지 않을 시 Path가 맞지 않으므로 주의

Reverse Drill & Screw Remover

Screw가 Talon Drill로 제거가 되지 않았을 경우

- ① 파결된 Screw에 Hole 형성 (깊이 1~2mm / 반시계방향 / 1,200~1,400 rpm)
- ② 형성된 Drill Hole에 맞추어 Screw Remover를 사용, 누르는 힘으로 파결된 Screw 제거 (반시계방향, 80Ncm)

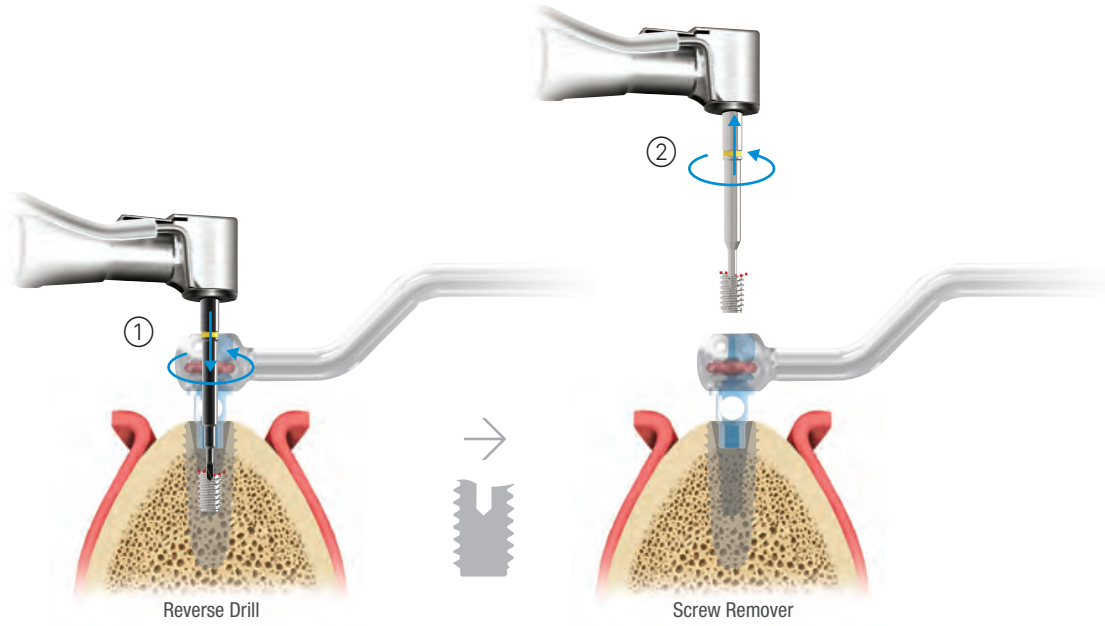

- ※ I Guide와 Fixture의 Path가 맞지 않을 시 Drill Hole이 Screw 중양을 벗어나 제거가 어려움
- ※ Reverse Drilling 시 irrigation 및 suction으로 chip 제거 필요
- ※ Reverse Drill Hole 생성 과정에서 Screw 가 제거될 수도 있음
- ※ 필요 시 Machine Adapter에 체결하여 손으로 직접 또는 Torque Wrench 연결 후 사용



3. Abutment Removal System

Abutment Remover

- ① 2 Pieces Type Abutment가 파결되었을 때 사용
- ② Abutment Remover 체결 (시계방향)
- ③ 완전히 체결 후 좌우로 흔들며 들어올려 제거

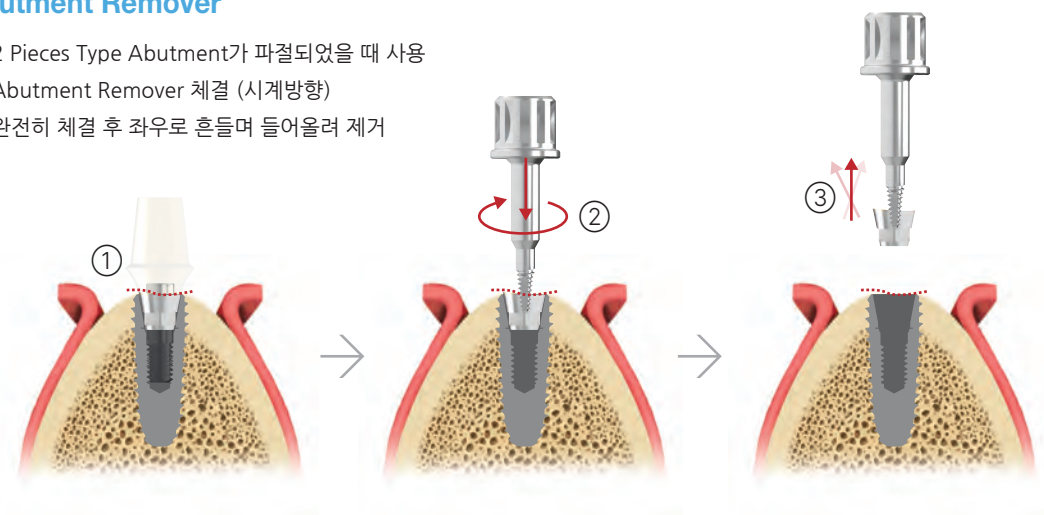

Tap Repair

- ① Fixture 내부의 나사산이 막히거나 손상되었을 때 사용
- ② Tap Repair를 사용하여 나사산을 재생 (시계방향)

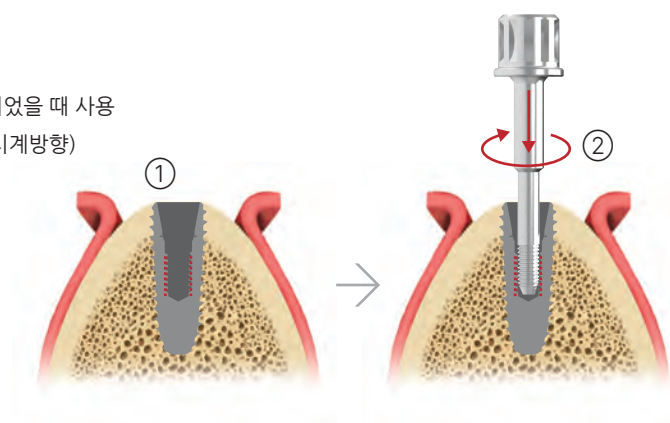

Slot Driver

- ① 1 Piece Type Abutment, Healing Abutment, Cover Screw 파절 시 사용
- ② Round bur를 사용하여 파절된 표면에 Slot 형성
- ③ Slot Driver를 형성된 slot에 체결 후 제거 (반시계방향)

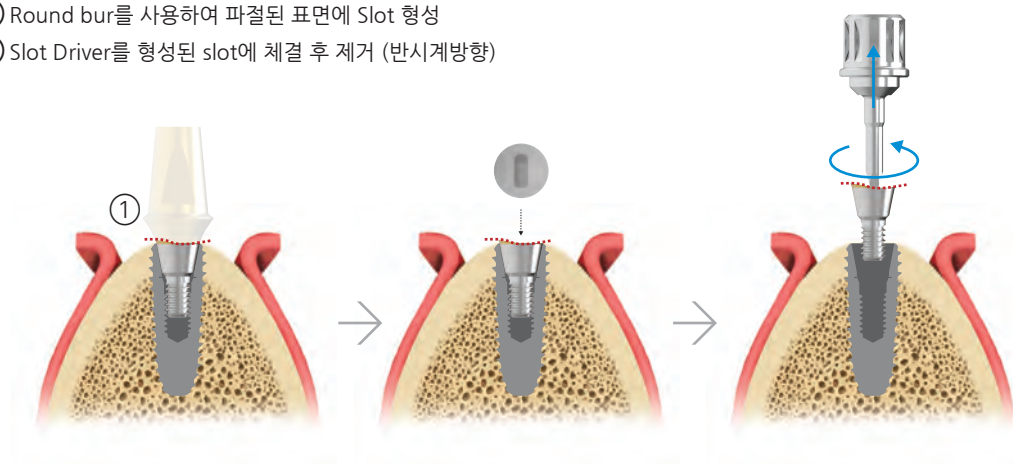

4. Torque Wrench

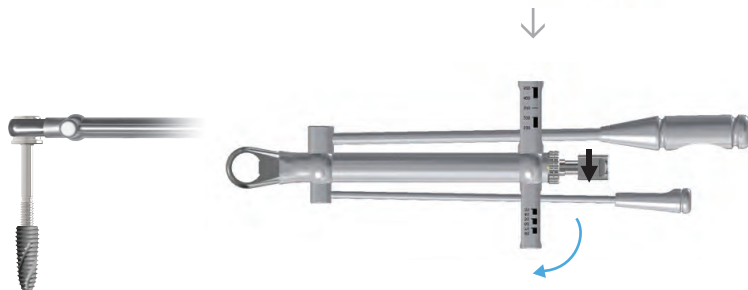
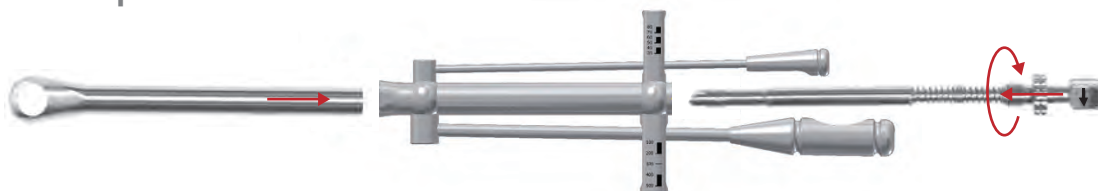

Fixture 식립
(시계방향, 40~80Ncm)

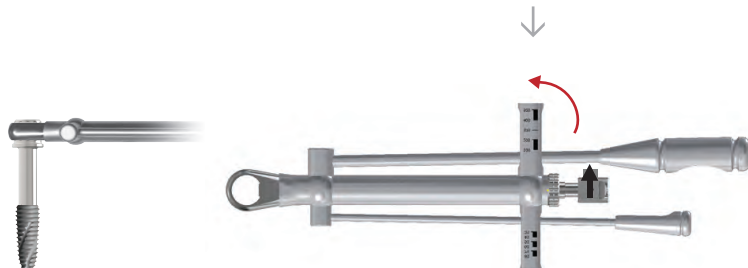

Fixture 제거
(반시계방향, 100~400Ncm)

InnoGenic GBR Kit [KIGBR001]

> 다양한 타입의 GBR 기술을 해결하는 All-in-one 솔루션

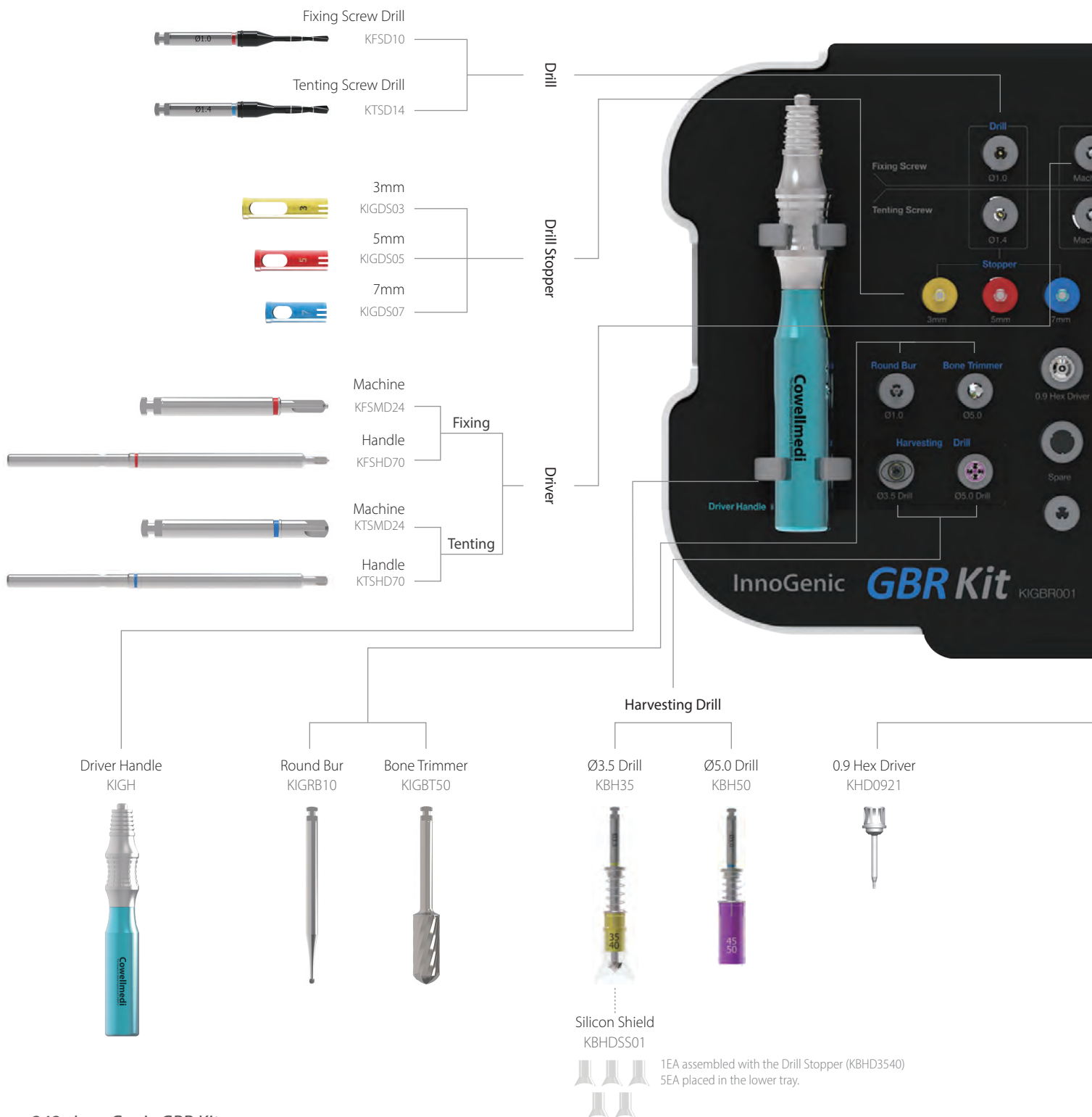

제품 길이는 Kit의 중간 tray에
눈금 표시로 측정 가능

0 3 5 7 10 13 15
15B 10 7 5 3 0



Fix Connector
F/Connector **Fixture**



Cover Cap
C/Cap



Healing Cap
H/Cap



Bone Carrier









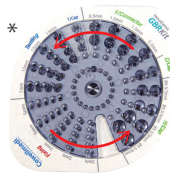









KBBC01

Screw Kit KIGICS001

- Kit tray 내부에 결합하여 사용 - 필요 시 분리하여 사용
- Autoclave 사용 가능
- *사용목적에 따라 회전하여 사용



Composition

Classification	Product	Code	Quantity
Bone	Fixing Screw (Fixing)	 KIGFS03	5
		 KIGFS05	5
		 KIGFS07	5
	Tenting Screw (Tenting)	 KIGTS07	4
		 KIGTS10	4
		 KIGTS13	4
		 KIGTS15	4
	Tenting Cap (T/Cap)	 KIGTC32	3
Fixture	Fix Connector (F/Connector)	 KIGFC4505	2
		 KIGFC4510	2
		 KIGFC4515	2
		 KIGFC4520	2
	Cover Cap (C/Cap)	 KIGCC45	2
	Healing Cap (H/Cap)	 KIGHC453	2
		 KIGHC454	2
		 KIGHC553	2
 KIGHC554		2	

Empty Screw Kit KIGICS



Bone

Fixing Screw (Fixing)

- 차폐막을 2차적으로 고정하기 위한 고정용 Screw
- Fixing Screw Driver (Machine/Handle)을 사용하여 천천히 식립
- 골질에 따라 3, 5, 7mm로 길이를 선택하여 사용할 수 있으며 Hard Bone에서는 Fixing Drill을 이용하여 기초 드릴 홀을 생성한 후 사용
- Self-tapping에 유리한 쐐기형 디자인으로 Normal Bone에서는 별다른 드릴링 없이 사용 가능
- Double Thread 적용으로 식립 시간 단축

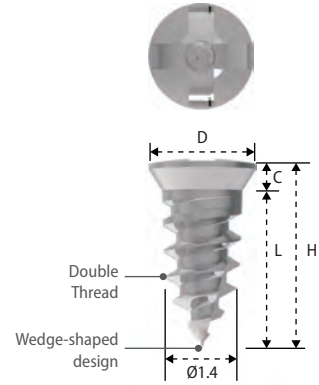

D(Ø,mm)	C(mm)	L(mm)	H(mm)	Code
2.0	0.6	3.0	3.6	KIGFS03
		5.0	5.6	KIGFS05
		7.0	7.6	KIGFS07

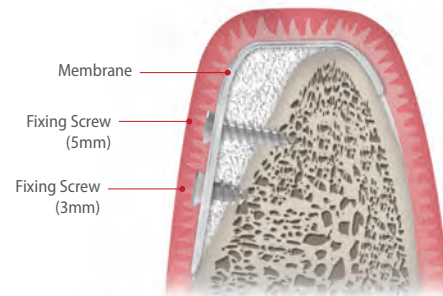

Bone

Tenting Screw (Tenting)

- 넓은 부위의 수직/수평 GBR이 필요한 경우 사용하며 Fixture 대응으로 사용 가능
- Tenting Screw Driver (Machine/Handle)를 사용하여 천천히 식립
- 권장 식립 깊이
 - Hard bone - 3mm, Normal bone - 5mm, Soft bone - 5mm 이상
- 최소 15N~25Ncm 초기 고정 필요, 반드시 35Ncm이하로 고정 (35Ncm 이상 체결 시 Screw 파절 가능성 있음)
- Normal bone 이상에서는 Tenting Screw Drill을 이용하여 천공을 최소 3mm 이상 형성하는 것을 권장
- Self-tapping에 유리한 쐐기형 디자인으로 Soft Bone에서는 별다른 드릴링 없이 사용 가능
- Double Thread 적용으로 식립 시간 단축
- Wifi-Mesh 등의 차폐막을 사용할 경우 Tenting Cap을 사용하여 고정 가능

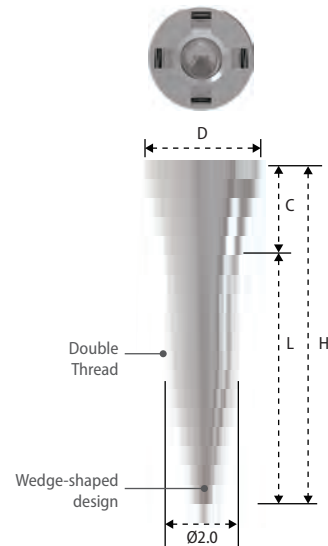

D(Ø,mm)	C(mm)	L(mm)	H(mm)	Code
3.2	2.5	7.0	9.5	KIGTS07
		10.0	12.5	KIGTS10
		13.0	15.5	KIGTS13
		15.0	17.5	KIGTS15

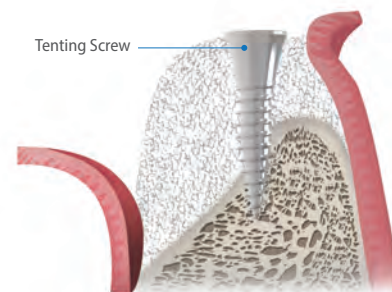

Bone

Tenting Cap (T/Cap)

- Tenting Screw에 차폐막을 고정시킬 때에 사용
- 0.9 Hex Driver와 체결
- 권장 체결 토크 : 5~8Ncm

D(Ø,mm)	C(mm)	L(mm)	H(mm)	Code
3.2	0.3	2.8	3.1	KIGTC32

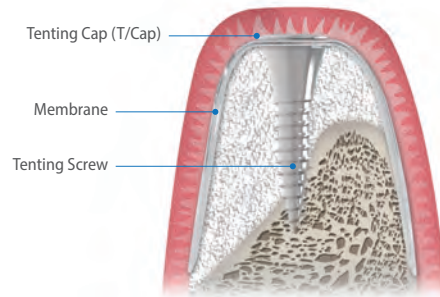
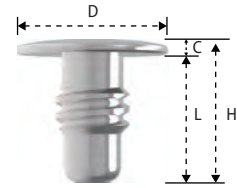

Fixture

Fix Connector (F/Connector)

- Fixture에 체결되며 차폐막을 Cover Cap 또는 Healing Cap과 고정시킬 때 사용
- 0.9 Hex Driver와 체결
- 권장 체결 토크 : 12~15Ncm
- INNO Submerged, Submerged Short Fixture와 호환 가능

D(Ø,mm)	C(mm)	L(mm)	H(mm)	Code
4.5	0.5	5.7	6.2	KIGFC4505
	1.0		6.7	KIGFC4510
	1.5		7.2	KIGFC4515
	2.0		7.7	KIGFC4520

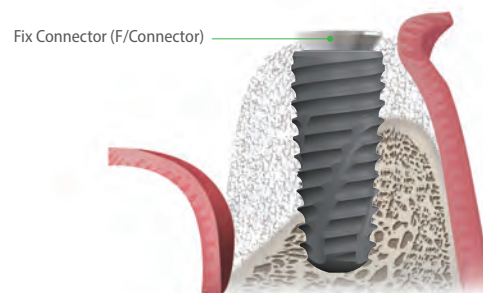

Fixture**Cover Cap (C/Cap)**

- Fix Connector에 차폐막을 고정시킬 때에 사용
- 연조직이 충분할 경우 Submerged로 시술
- 0.9 Hex Driver와 체결
- 권장 체결 토크 : 5~8Ncm

D(Ø,mm)	C(mm)	L(mm)	H(mm)	Code
4.5	0.3	3.4	3.7	KIGCC45

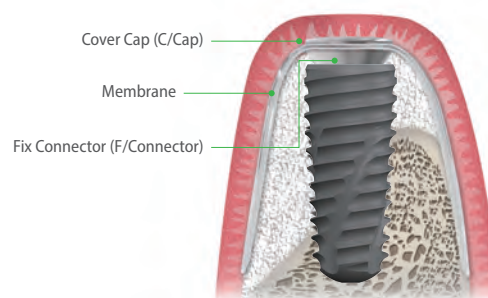
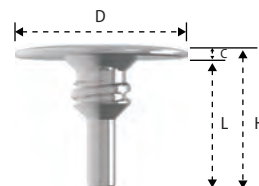
**Fixture****Healing Cap (H/Cap)**

- Fix Connector에 차폐막을 고정시킬 때에 사용
- 연조직이 불충분할 경우 Non-submerged로 시술
- 0.9 Hex Driver와 체결
- 권장 체결 토크 : 5~8Ncm

D(Ø,mm)	C(mm)	L(mm)	H(mm)	Code
4.5	3.0	3.4	6.4	KIGHC453
	4.0		7.4	KIGHC454
5.5	3.0		6.4	KIGHC553
	4.0		7.4	KIGHC554

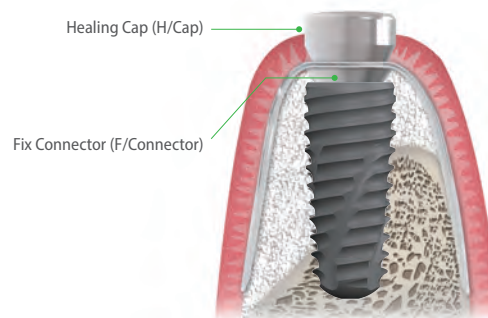
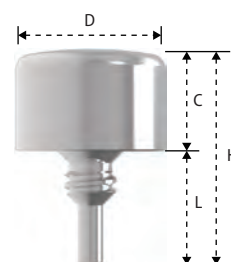

Fixing Screw Drill & Tenting Screw Drill

- Fixing Screw / Tenting Screw 식립 전 드릴링 시 사용
- Fixing Screw Ø1.0 / Tenting Screw Ø1.4
- 혈액 공급이 필요할 때 피질골 천공에도 사용
- Hard Bone 이상 사용 권장, Normal Bone 이하 : 3mm만 드릴링 후 사용
- Drill에 레이저로 3, 5, 7mm 길이 표시로 Drill Stopper를 사용하여 길이 조절 가능
- 색상 밴드로 구분 (빨강 : Fixing Screw Drill, 파랑 : Tenting Screw Drill)
- 권장 드릴 속도 : 1,000~1,200rpm

Classification	D(Ø,mm)	L(mm)	H(mm)	Code
Fixing Screw Drill	1.0	10	31.5	KFSD10
Tenting Screw Drill	1.4			KTSD14

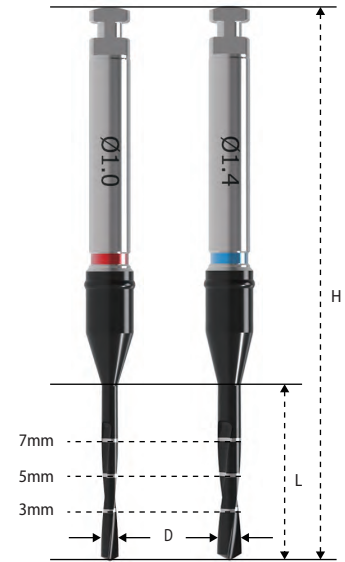
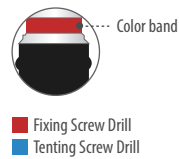

Drill Stopper

- Fixing Screw Drill / Tenting Screw Drill에 체결하여 사용
- 3mm : 노랑, 5mm : 빨강, 7mm : 파랑

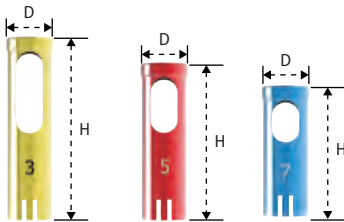

Classification	D(Ø,mm)	H(mm)	Code
3mm	3.5	13.5	KIGDS03
5mm		11.5	KIGDS05
7mm		9.5	KIGDS07



0.9 Hex Driver (Ratchet)

- Tenting Cap, Fix Connector, Cover Cap 및 Healing Cap 고정

D(Ø,mm)	L(mm)	H(mm)	Code
1.2	8	15	*KHD0915
	14	21	KHD0921
	20	27	*KHD0927

* Optional

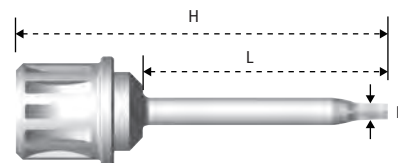

Fixing Screw Driver & Tenting Screw Driver (Machine)

- Contra-angle을 이용한 Fixing Screw / Tenting Screw 식립 시 사용
- Fixing Screw Ø1.6 / Tenting Screw Ø2.2
- 색상 밴드로 구분 (빨강 : Fixing Screw Driver, 파랑 : Tenting Screw Driver)

Classification	D(Ø,mm)	L(mm)	H(mm)	Code
Fixing Screw Driver	1.6	6.0	24.0	KFSMD24
Tenting Screw Driver	2.2			KTSM24

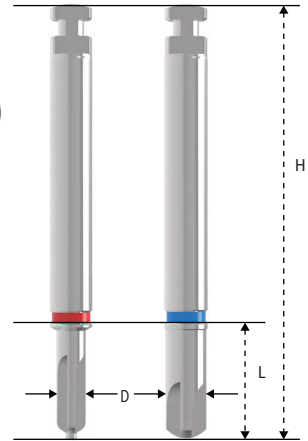
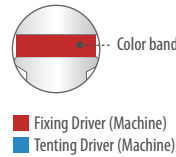

Fixing Screw Driver & Tenting Screw Driver (Handle)

- Driver Handle을 이용한 Fixing Screw / Tenting Screw 식립 시 사용
- Fixing Screw Ø1.6 / Tenting Screw Ø2.2
- 색상 밴드로 구분 (빨강 : Fixing Screw Driver, 파랑 : Tenting Screw Driver)

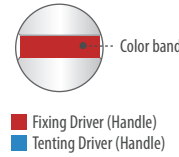
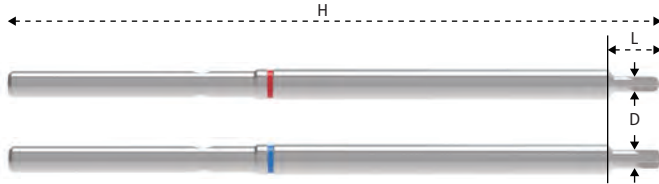

Classification	D(Ø,mm)	L(mm)	H(mm)	Code
Fixing Screw Driver	1.6	6.0	70.0	KFSHD70
Tenting Screw Driver	2.2			KTSHD70

Driver Handle

- Handle용 Driver를 연결하여 Fixing Screw / Tenting Screw를 손으로 체결하거나 제거 시 사용

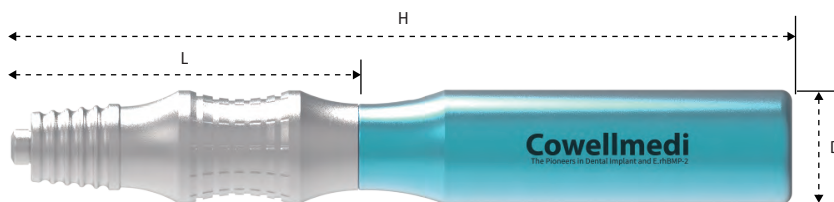

D(Ø,mm)	L(mm)	H(mm)	Code
19.8	75	135.0	KIGH

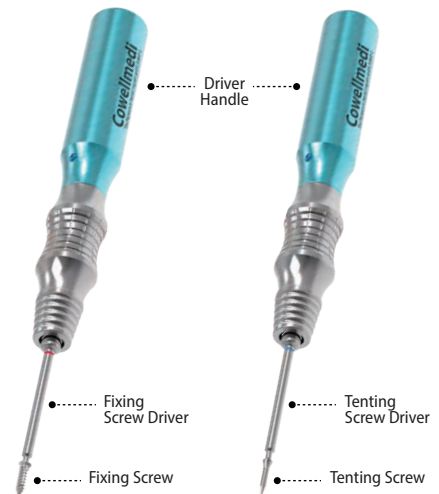

Round Bur

- 골재생에 필요한 Blood supply을 위한 Cortical Bone 천공용으로 사용
- 권장 드릴 속도 : 1,200~1,500rpm

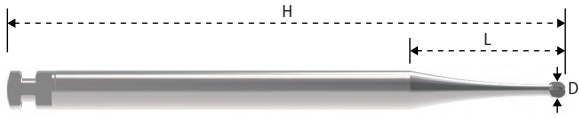

D(Ø,mm)	L(mm)	H(mm)	Code
1.0	9.5	34.0	KIGRB10

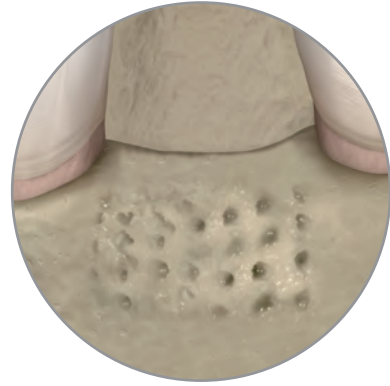

Bone Trimmer

- GBR시 잔존하는 골벽의 외벽에 Osteoplasty를 시행하고 Membrane 적합도를 향상시키기 위하여 평탄화 시 사용
- Immediate placement나 bone defect part의 잔존하고 있는 Granulation tissue를 제거 시 사용 (Surgical curette 대신 사용)
- 권장 드릴 속도 : 1,200~1,500rpm

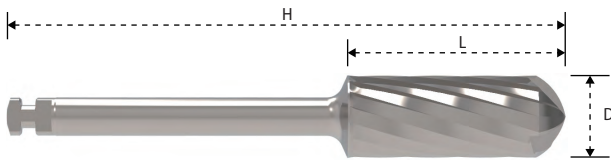

D(Ø,mm)	L(mm)	H(mm)	Code
5.0	13	34.0	KIGBT50

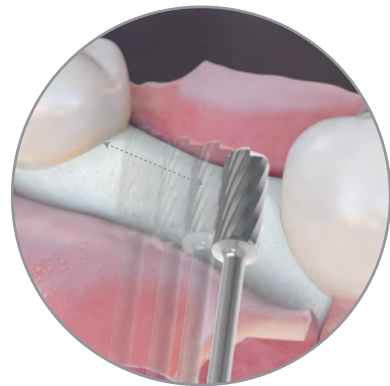

Harvesting Drill & Drill Stopper

- 자가골을 Bone chip의 형태로 짧은 시간에 편리하게 채취하기 위한 Drill
- Ø3.5 Drill Silicon Shield를 사용하여 소실되는 Bone chip 없이 채취 가능 (Implant site에서의 Bone chip 채취 가능)
- 권장 드릴 속도 : 300~500rpm
- Drill 및 Stopper 사용 횟수 : 50회
- Ø3.5 Drill의 경우 최대 Drilling 깊이가 12mm이므로 천천히 드릴링
- 자가골 채취 후 Drill이 빠지지 않을 경우 Drill을 회전시킨 상태에서 제거

D(Ø,mm)	L(mm)	H(mm)	Code
3.5	9.5	39.2	KBH35
5.0	6.5	36.5	KBH50

Drill Stopper	D(Ø,mm)	H(mm)	Code
	5.6	9	KBHD3540
	6	14.3	KBHD4550

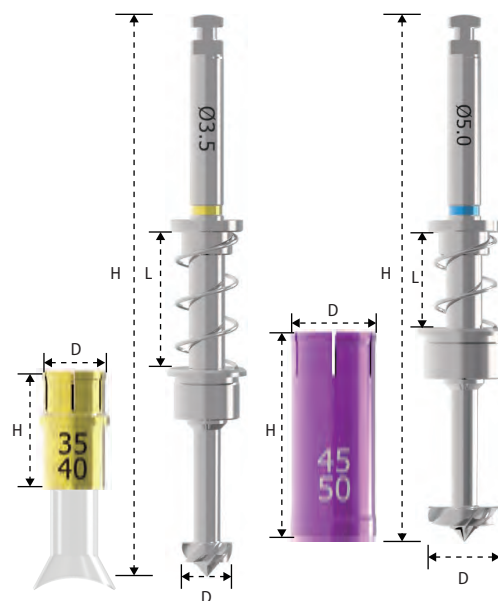

* 자세한 내용은 InnoGenic® Autobone Harvester 페이지 참조

Bone Carrier

- 좁은 입구로 인해 터널식 골이식술, 상악동 골이식술 등 대부분의 골이식술에 사용 가능
- 골이식재를 감염 없이 이식부에 정확하고 안전하게 주입 가능
- 삽입부의 원형 홈으로 인해 임플란트에 COWELL BMP 용액 코팅 용이
- COWELL BMP 용액과 골이식재를 원형 홈에 혼합하여 사용

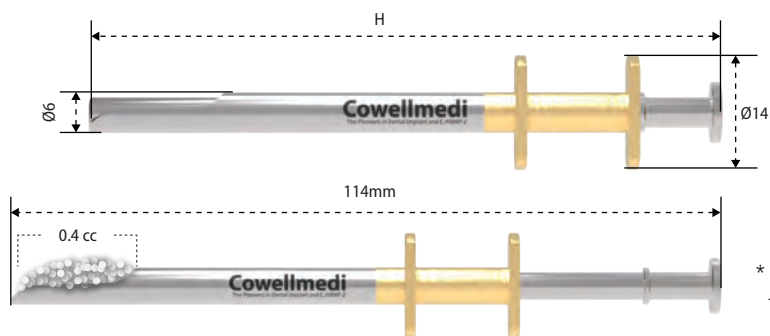

* Bone Carrier 길이는 94mm이며 원형홈이 노출 되었을 때의 총 길이는 114mm

Bone Carrier	D(Ø,mm)	H(mm)	Code
	6	94	KBBC01

Bone Profiler Kit [KBP001]

- > 1,2차 수술 시 Fixture 주위 골 제거 시 사용
- > Drill Guide를 Connection에 따라 Fixture에 연결 후 간섭되는 골을 삭제하여 Healing Abutment 체결
- > Drill Guide가 Drilling 시 Fixture와 직접 접촉하지 않아 Fixture 손상 방지

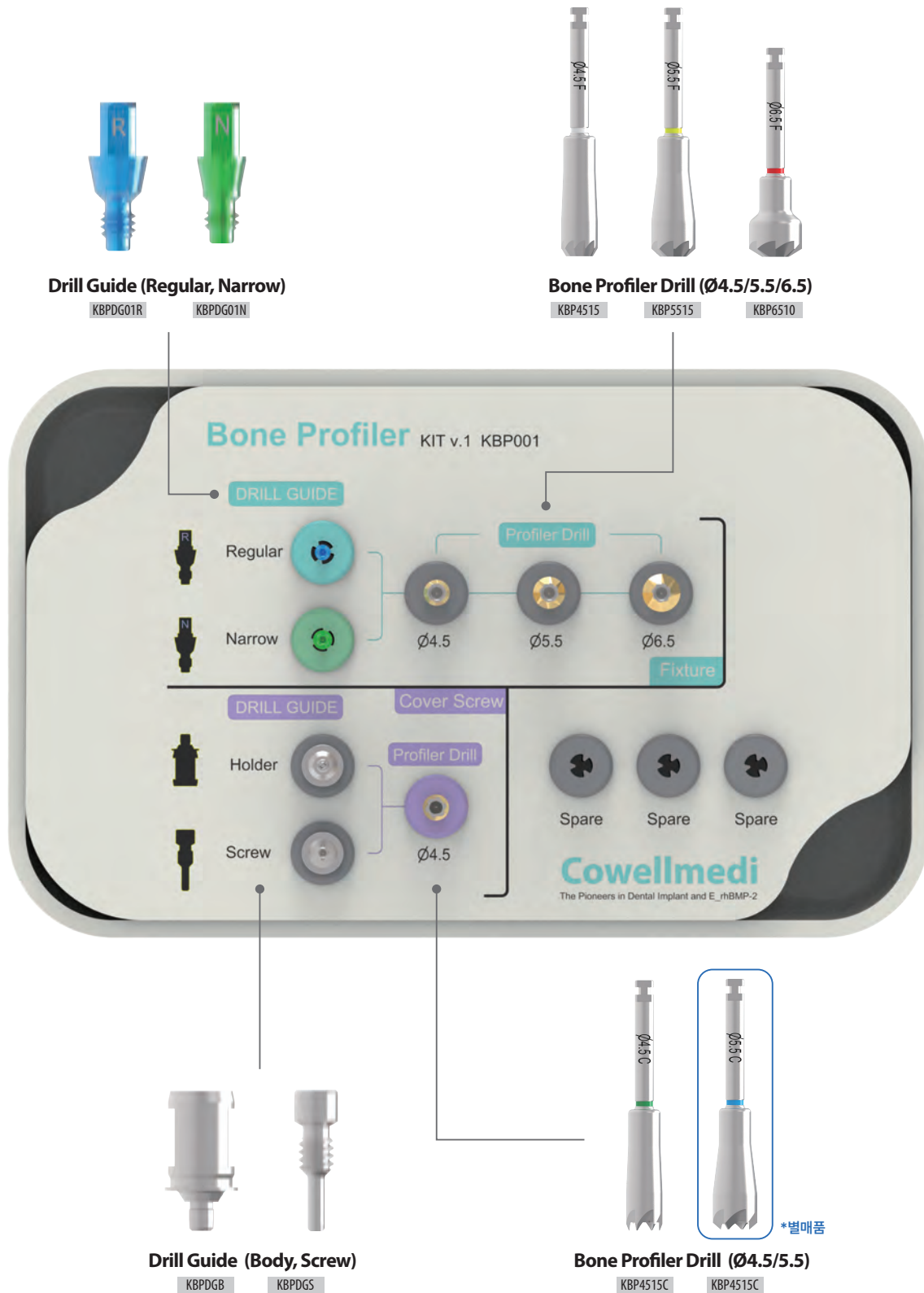

Bone Profiler Drill Fixture

- > Fixture 주위 골 제거 시 사용
- > Fixture에 Drill Guide (Fixture) 체결 후 사용
- > 회전 방향 CW / 800~1200RPM



Code	D(Ø)	L(mm)	H(mm)	Color Band
KBP4515	4.5	15	31	White
KBP5515	5.5	15	31	Yellow
KBP6510	6.5	10	26	Red

·드릴의 중앙 홀에 드릴가이드가 연결되어
정확한 위치에 드릴링이 가능

Drill Guide Fixture

- > Bone Profiler Drill (Fixture)의 가이드 역할
- > Fixture에 1.2 Hex Driver를 이용하여 Hand Force(10~15Ncm)로 체결
- > Fixture Connection에 따라 Color 구분 (Sub Regular : Blue, Sub Narrow : Green)

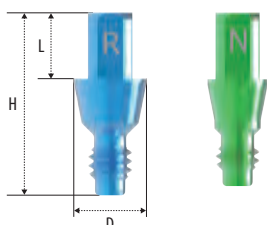

Code	D(Ø)	L(mm)	H(mm)	Color Band
KBPDG01R	3.3	3	8.3	Blue
KBPDG01N	2.63	3	7.82	Green

Bone Profiler Drill

Cover Screw

- > Cover Screw 주위 골 제거 시 사용
- > Cover Screw에 Drill Guide (Cover Screw) 체결 후 사용
- > 회전 방향 CW / 800~1200RPM

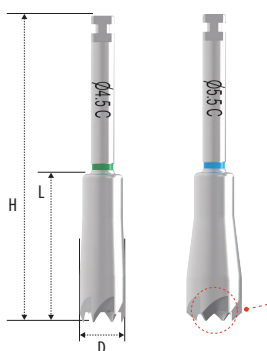

Code	D(Ø)	L(mm)	H(mm)	Color Band
KBP4515C	4.5	15	31	Green
*KBP5515C	5.5	15	31	Blue

* 별매품

·드릴의 중앙 홀에 드릴가이드가 연결되어
정확한 위치에 드릴링이 가능

Drill Guide Cover Screw

- > Bone Profiler Drill (Cover Screw)의 가이드 역할
- > Cover Screw의 1.2 Hex 홀에 체결하여 사용
- > 1.2 Hex Driver를 이용하여 Hand Force(10~15Ncm)로 체결

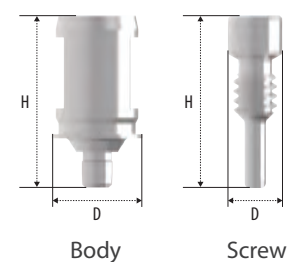

Code	D(Ø)	H(mm)
KBPDGB	3.3	6.3
KBPDGS	1.95	6.3

안전높이

Fixture

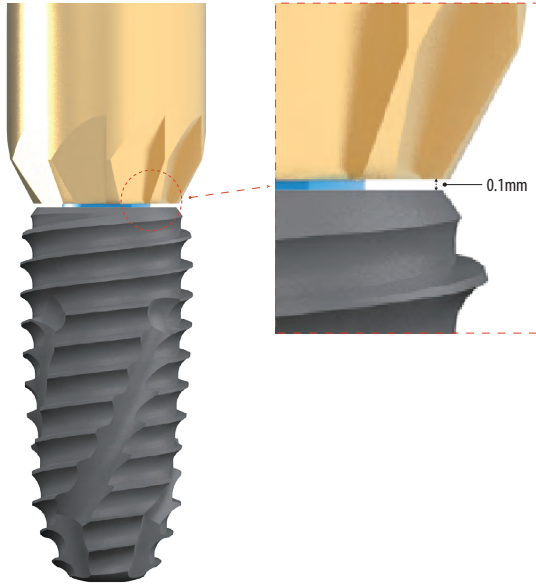

Cover Screw

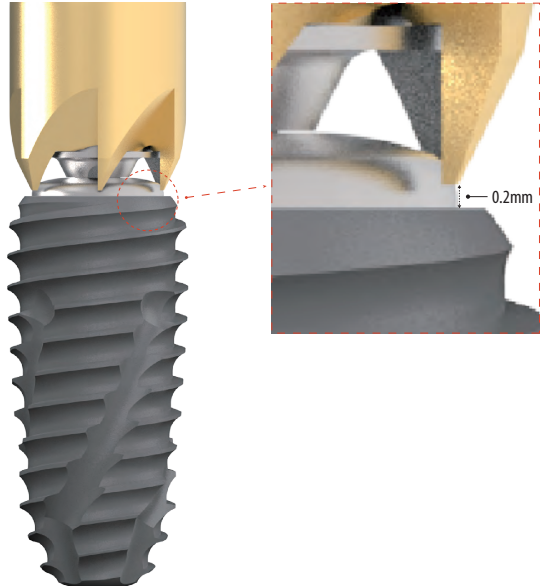

사용 방법

Fixture

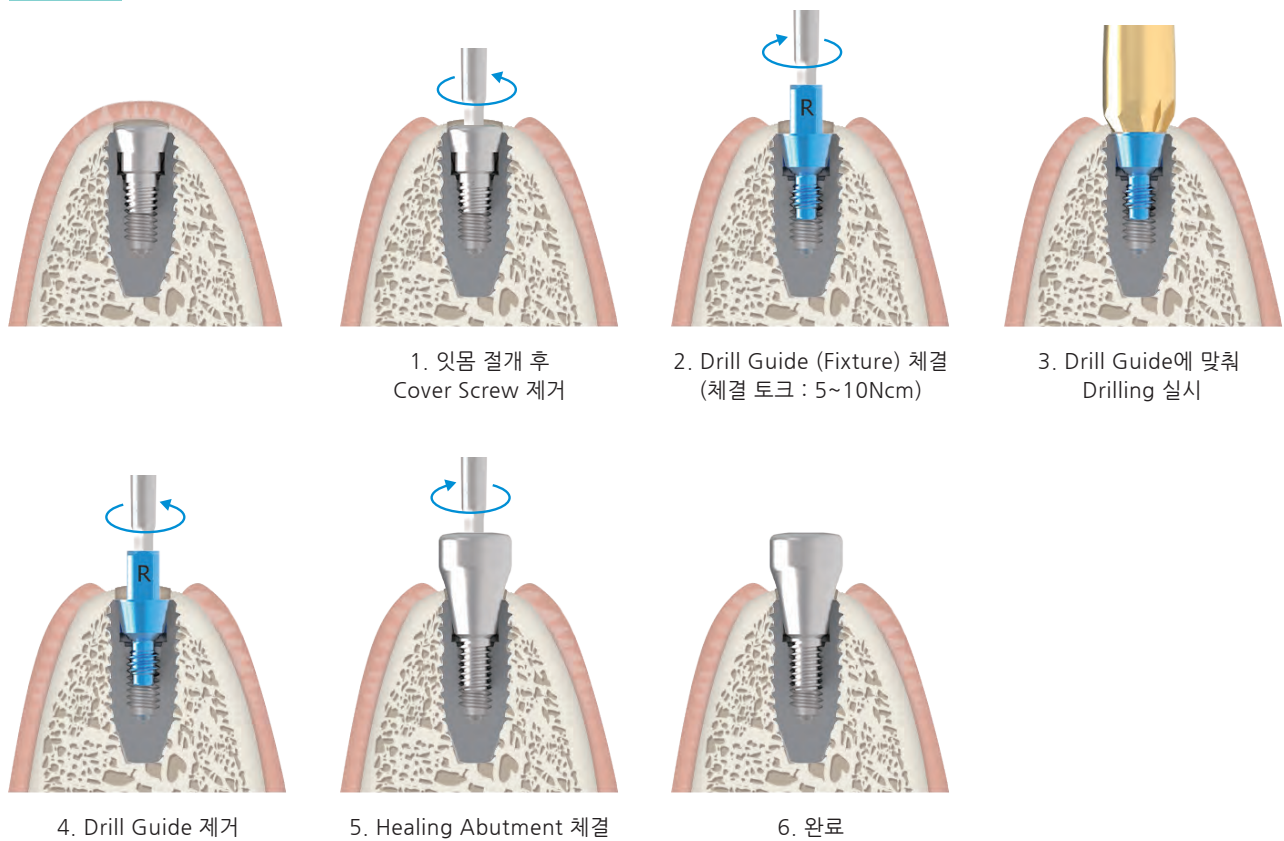

Cover Screw

· Cover Screw 주위에 Bone이 약간만 덮고 있는 경우(Hole 노출)

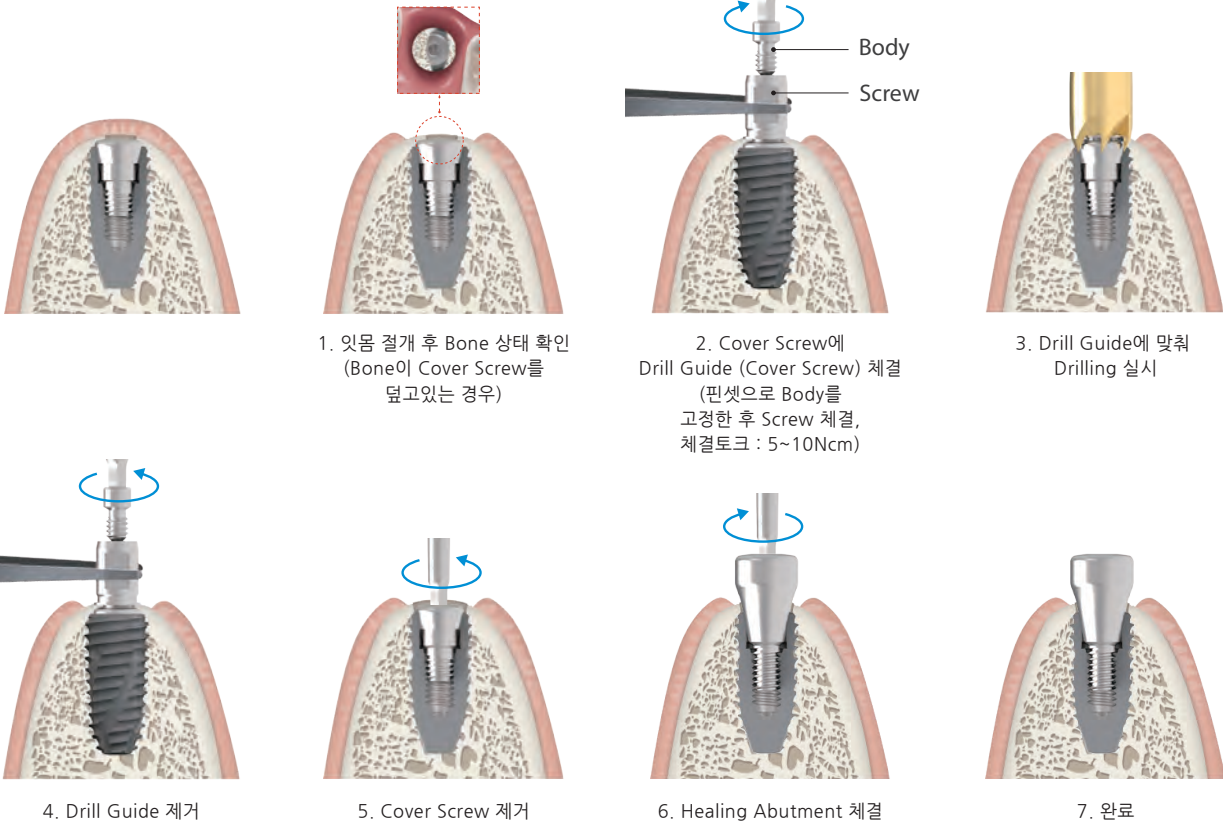

· Cover Screw 주위에 Bone이 덮고 있는 경우

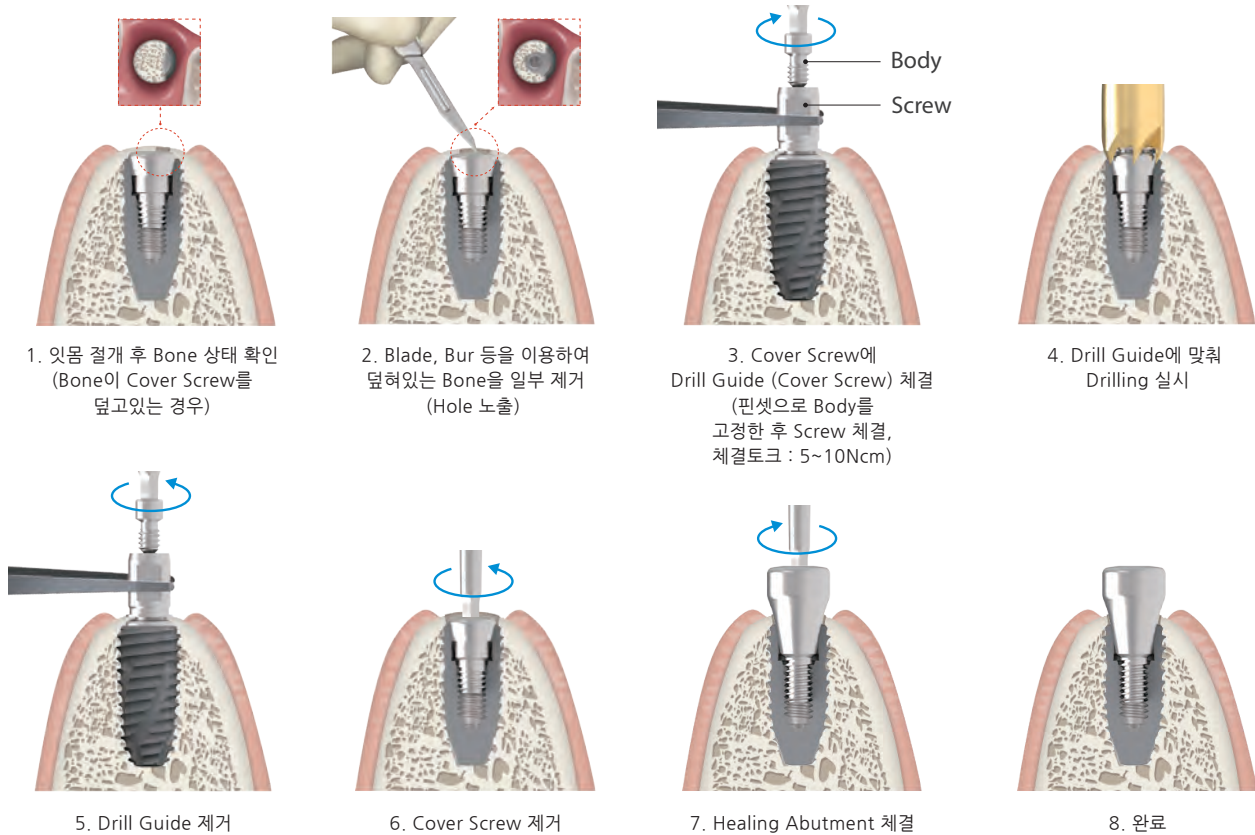

Clinical Case 1

Cover Screw



1. 치은 절개 후 Bone 상태 확인



2. Cover Screw에 Drill Guide (Cover Screw) 체결 (핀셋으로 Body를 고정 후 Screw 체결)



3. Drill Guide에 맞춰 Drilling 실시

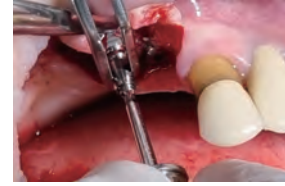

4. Drill Guide 제거



5. Cover Screw 제거



6. Healing Abutment 체결



7. 완료

Clinical Case 2

Cover Screw

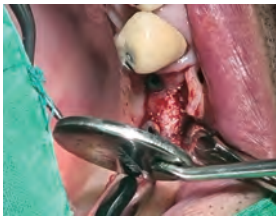

1. 치은 절개 후 Bone 상태 확인



2. Cover Screw에 Drill Guide (Cover Screw) 체결 (핀셋으로 Body를 고정 후 Screw 체결)



3. Drill Guide에 맞춰 Drilling 실시



4. Drill Guide 제거



5. Cover Screw 제거

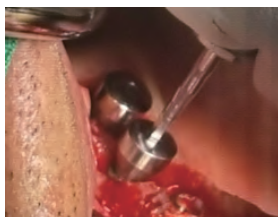

6. Healing Abutment 체결

Clinical Case 3

Cover Screw



1. 치은 절개 후
Bone 상태 확인

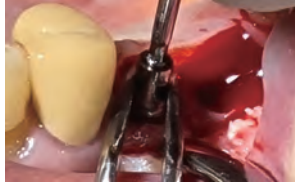

2. Cover Screw에
Drill Guide (Cover Screw) 체결
(핀셋으로 Body를
고정한 후 Screw 체결)



3. Drill Guide에 맞춰
Drilling 실시

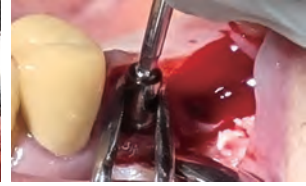

4. Drill Guide 제거



5. Cover Screw 제거

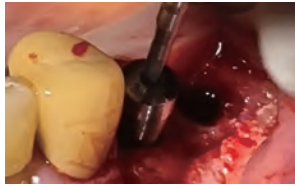

6. Healing Abutment 체결

InnoGenic Autobone Harvester [KIAH001]

> 임플란트 부위에서 Bone Chip을 손쉽게 채취하여 즉시 골이식재로 적용



Harvesting Drill

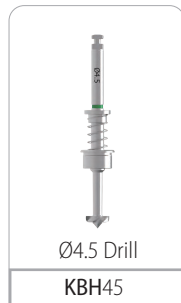
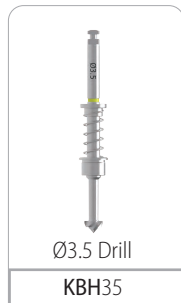

Drill Stopper



Silicon Shield



* 1EA는 Drill Stopper (KBHD3540)에 조립.
5EA는 중판 밑에 위치.

1. InnoGenic Autobone Harvester의 장점

- > 짧은 시간에 편리하게, 확실한 효과 기대
- > 복잡하고 어렵게 채취되던 Bone Chip을 짧은 시간에 편리하게 채취하여 사용
- > 골이식재 구입 비용을 절감

2. 제품소개

- > Drill 특징

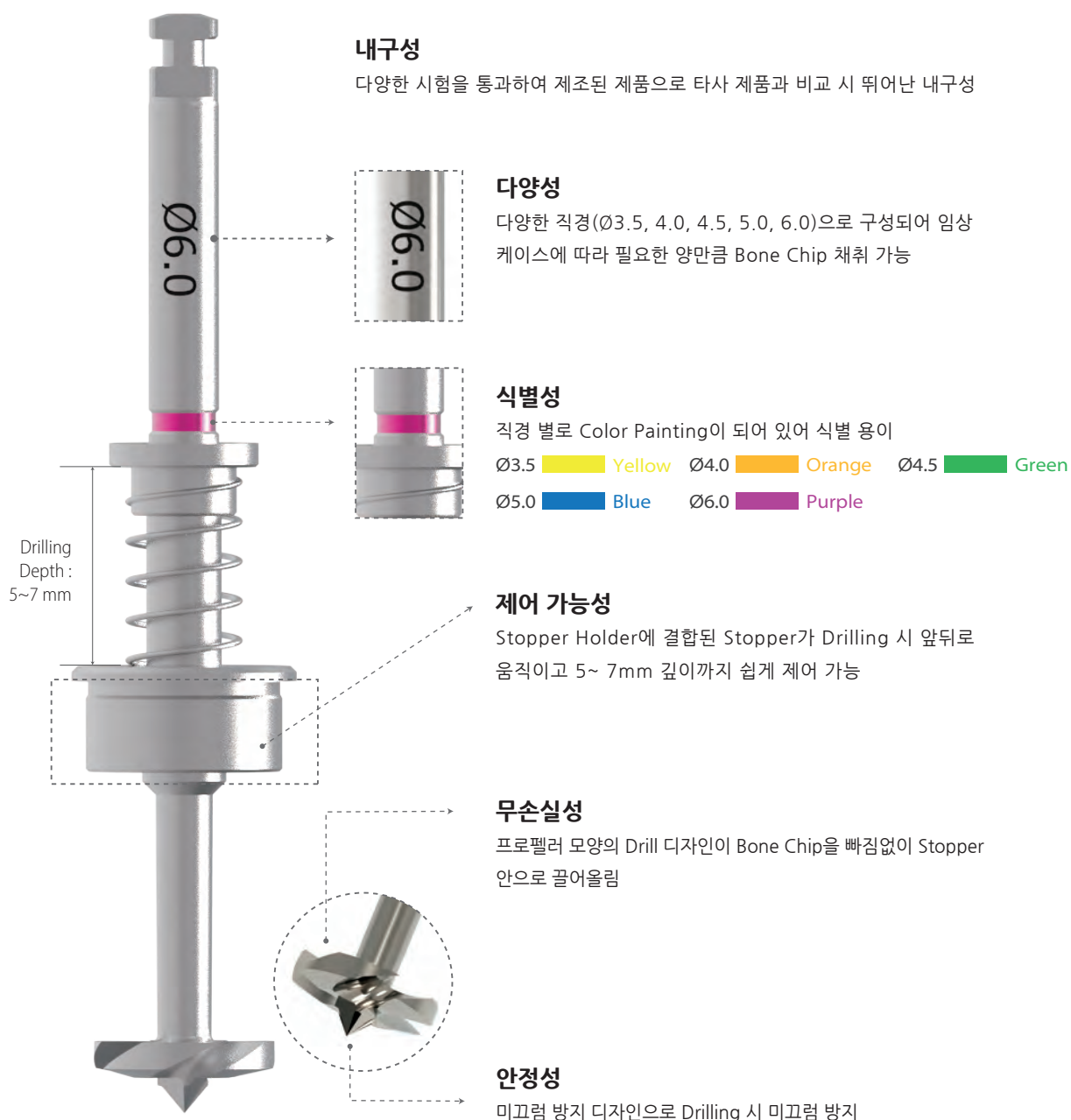

Stopper와 Silicon Shield 특징

For Ø3.5 & 4.0 Drill



Stopper

Ø3.5, 4.0 Drill과 결합.

+



Silicon Shield (*Exclusive for Ø3.5 & 4.0)

- Ø3.5 및 4.0 Stopper에 결합
- Bone Chip 이탈 방지
- Implant 식립 부위의 Bone Chip 채취 가능
- 재사용이 가능한 투명 실리콘 재질로 Drill 위치 확인 및 Bone Chip 채취 가능



Shield

곡면의 Shield는 골에 최대한 밀착 가능하게 하여 Drilling 시 Bone Chip 이탈 방지

For Ø4.5 & 5.0 Drill



Stopper

Ø4.5, 5.0 Drill과 결합

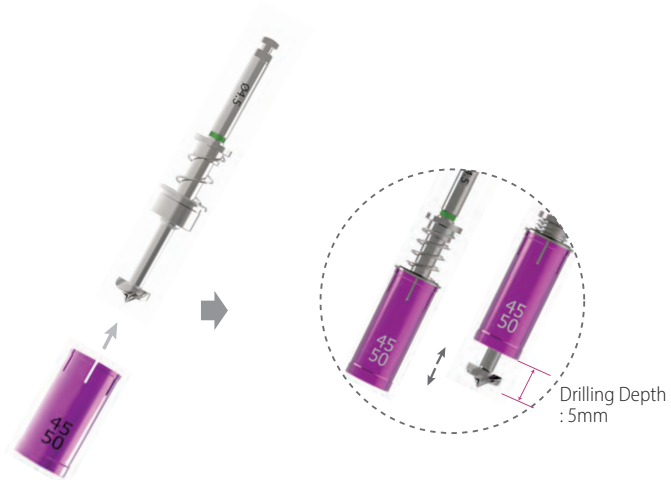

For 6.0 Drill



Stopper

Ø6.0 Drill과 결합

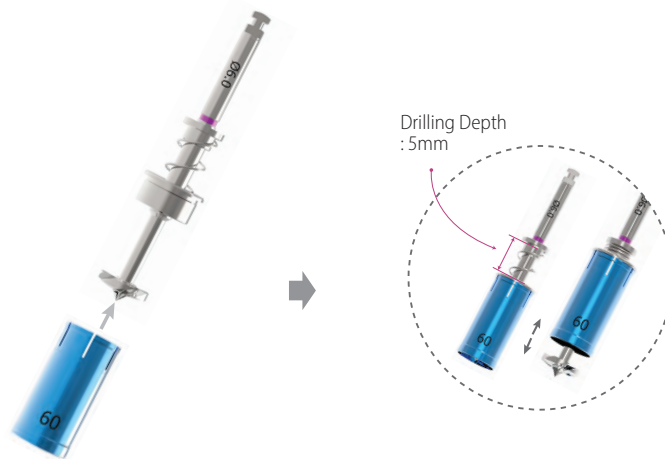

Harvesting sequence:

Implant Site using Ø3.5/4.0

Harvesting Drill with the Silicon Shield



· Point Drill을 이용하여 Bone Chip 채취 및 implant 식립 부위 표시



· Ø3.5 / 4.0 Drill 선택 후 Stopper 체결 (Shield는 Stopper와 미리 결합)



· 주수하면서 300~500rpm으로 Drilling하여 Bone Chip 채취 (상악과 같은 Soft Bone의 경우 100rpm 권장)



· Shield와 Stopper를 분리하여 골 이식에 필요한 Bone Chip 수집



· 제조사의 Drilling 프로토콜 따라 Final Drill 사용



· Implant 식립



· 채취된 Bone Chip을 결손 부위에 이식

Harvesting sequence: Buccal Bone Harvesting using Ø3.5/4.0/4.5/5.0/6.0 Harvesting Drill

직경 및 Clinical indication에 따라 Drill 선택

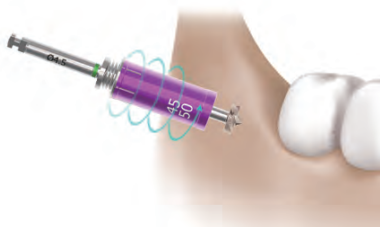
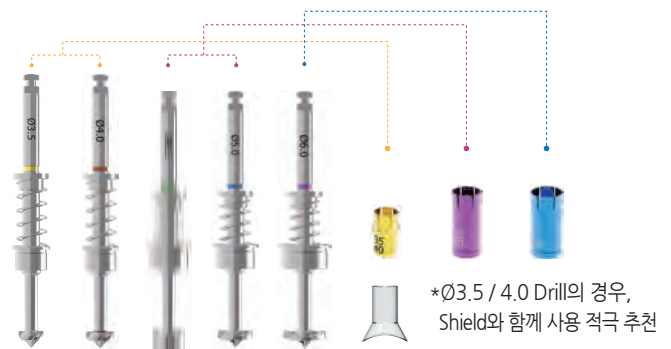

• 주수하면서 300~500rpm으로 Drilling하여 Bone Chip 채취



• Implant 식립 부위 주변으로 채취 된 Bone Chip 이식

Ø3.5/4.0 Harvesting Drill을 사용한 임상례

by Dr. Soohong Kim, DDS, Ph.D



Implant 및 채취 부위 확인 후 주수하면서 300rpm으로 Drilling



Shield를 다양한 골 높이에 따라 밀착하여 Bone Chip 손실 방지



투명한 Shield를 통해 골 채취량을 쉽게 확인



Drill에서 Shield와 Stopper를 분리한 뒤 채취 된 Bone Chip을 Bone Dish에 옮김



Implant 식립 후, Healing Abutment 결합하고 결손 부위에 GBR 이행

* 4mm Drill로 Drilling 후 Stopper 및 Shield에 Bone Chip이 가득 찰 시, 채취한 Bone Chip을 그릇에 옮긴 뒤 7mm Drill로 변경

COWELL BMP Trepine Kit [KBT001]

> 자가골 이식 시 블록형 Bone 채취 및 Failed Fixture 제거, Sinus Lift 및 임플란트 식립 전 Bone Chip 채취용 Drill로 구성된 편리한 Kit

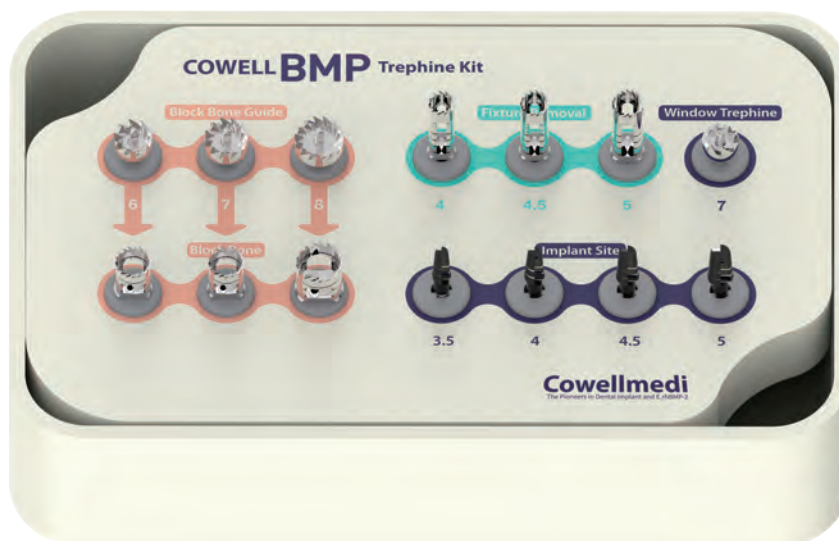

Trepine Drill I: Block Bone Extraction

Guide & Block Bone Trepine Drill

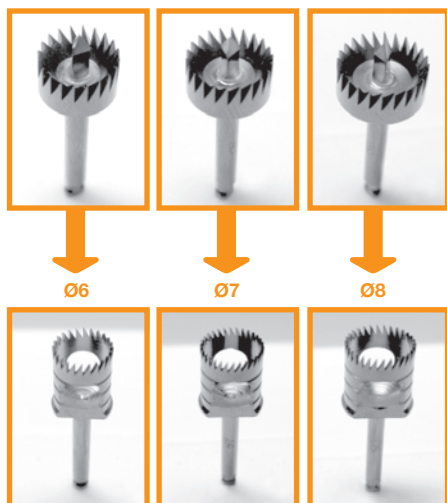

Trepine Drill II:

식립 실패 Fixture 제거

Fixture Removal

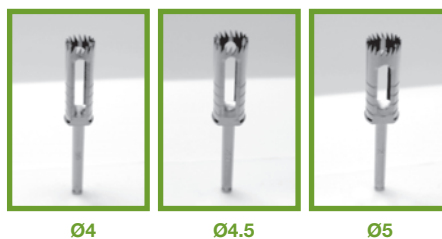

Trepine Drill III:

측방접근법 시 측방 개방

Window Trepine



Implant Site Drill: Sinus Lift 및 임플란트 식립 전 Bone Chip 채취용

Implant Site

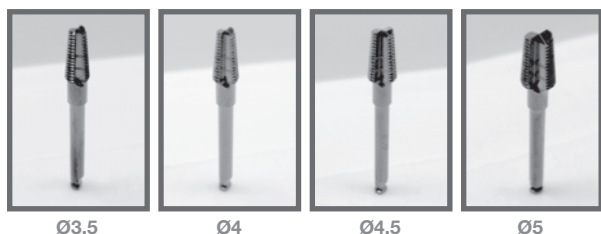

Product	Diameter	Code
Block Bone Guide Drill	Ø 6.0 (Inner)	KBGT60
	Ø 7.0 (Inner)	KBGT70
	Ø 8.0 (Inner)	KBGT80
Block Bone Trepine Drill	Ø 6.0 (Inner)	KBT60
	Ø 7.0 (Inner)	KBT70
	Ø 8.0 (Inner)	KBT80
Fixture Removal Trepine Drill	Ø 4.2 (Inner)	KFRT40
	Ø 4.7 (Inner)	KFRT45
	Ø 5.2 (Inner)	KFRT50
Window Trepine Drill	Ø 7.0 (Outer)	KWTT60
Implant Site Drill	Ø 3.5 (Fixture)	KTIS35
	Ø 4.0 (Fixture)	KTIS40
	Ø 4.5 (Fixture)	KTIS45
	Ø 5.0 (Fixture)	KTIS50

Trephine Drill I Block Bone 채취

광범위한 골결손부와 심하게 흡수된 골조직의 재생시 필요한 크기의 블록형 자가골을 채취할 수 있도록 함

Block Bone Guide

- > 채취하고자 하는 Block Bone의 정확한 위치 선정과 Trephine Drill이 안정적으로 Bone에 Engage되도록 함
- > 권장 드릴 속도 : 800~1,000 rpm

Diameter	Ø 6.0 (Inner)	Ø 7.0 (Inner)	Ø 8.0 (Inner)
	KBGT60	KBGT70	KBGT80

Block Bone Trephine Drill

- > Block Bone Guide에 의한 골홈에 Engage하여 원하는 크기의 Block Bone 채취
- > 권장 드릴 속도 : 800~1,000 rpm

Diameter	Ø 6.0 (Inner)	Ø 7.0 (Inner)	Ø 8.0 (Inner)
	KBT60	KBT70	KBT80

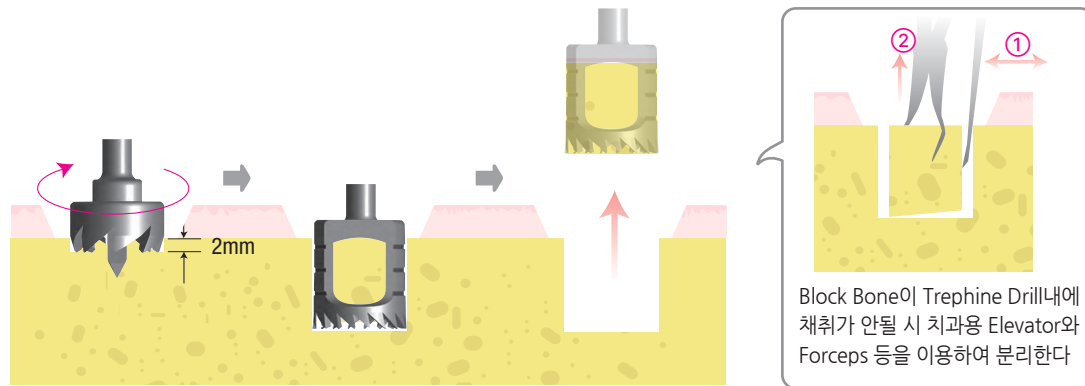

Trephine Drill II Failed Fixture 제거

- > KFRT40 : Ø4.0 Fixture 제거용 / KFRT45 : Ø4.5 Fixture 제거용 / KFRT50 : Ø5.0 Fixture 제거용
- > 권장 드릴 속도 : 800~1,000 rpm

Diameter	Ø 4.2 (Inner)	Ø 4.7 (Inner)	Ø 5.2 (Inner)
	KFRT40	KFRT45	KFRT50

Trephine Drill III 측방 접근법

Diameter	Ø 7.0 (Outer)
KWTT60	

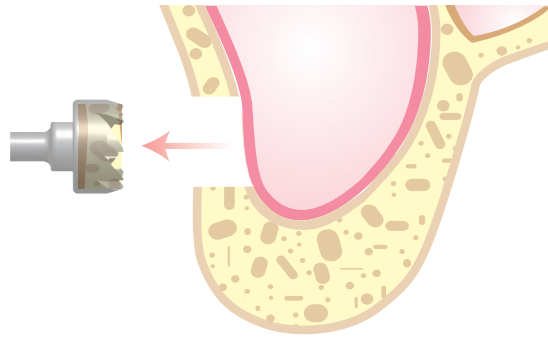
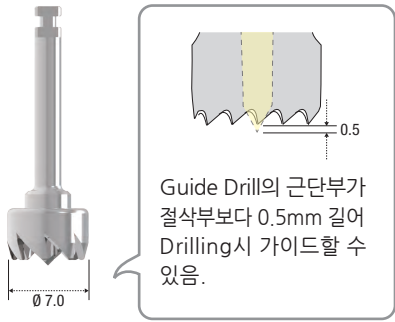

Implant Site Drill 상악동 거상 & implant 식립 전 Bone Chip 채취용

Diameter	Ø 3.5	Ø 4.0	Ø 4.5	Ø 5.0
	KTIS35	KTIS40	KTIS45	KTIS50



- > Final Drill을 사용하기 위한 이전 드릴 (Drill Sequence 간편화)
- > 자가골 확보에 유리
- > 낮은 rpm으로 Drilling 하여 Bone Heating 적음
- > 상악동 거상 Tool로도 사용할 수 있음
- > 권장 드릴 속도 : 20~30 rpm

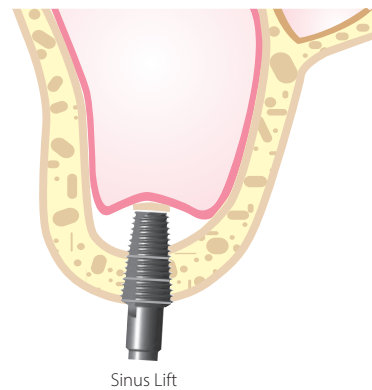
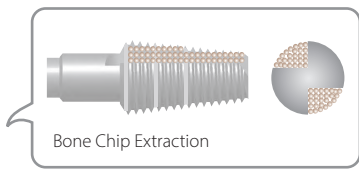

Atraumatic Extraction Kit [KAE001]

> 치아의 Root를 간단한 시술법으로 빠르고 편리하게 발치

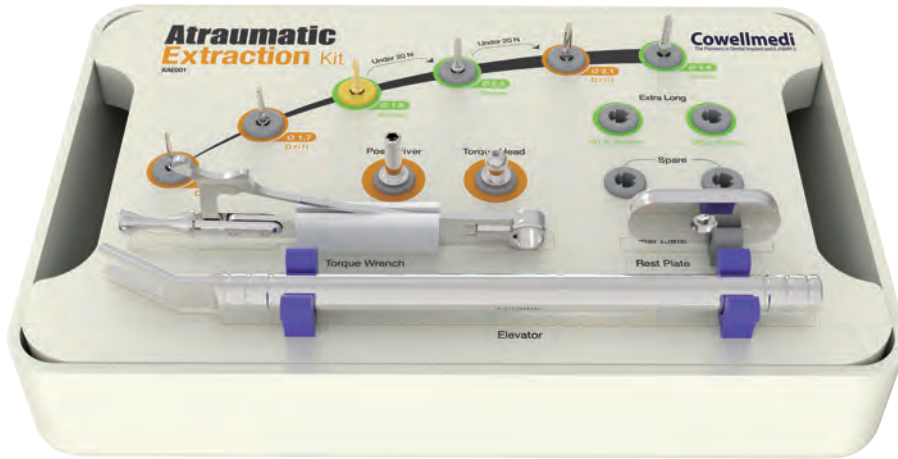

(1) 다양성

치근의 잔존량이 많거나 적은 경우에도 발치 가능

(2) 안전성

Rest Plate, Elevator 등을 사용하여 직접적으로 치아에 손상을 입히지 않고 발치

(3) 편리성

매우 간단하면서도 편리하게 발치

(4) 시술 시간 감소

간단한 시술방법으로 시술시간 감소

Composition

<p>Extraction Drill & Screw</p> <p>Ø 1.3 Drill Ø 1.7 Drill Ø 1.8 Screw Ø 2.2 Screw Ø 2.1 Drill Ø 2.6 Screw</p>	<p>Rest Plate</p>		
	<p>Torque Wrench</p>		
<p>Elevator</p>	<table border="1"> <tbody> <tr> <td data-bbox="954 1832 1187 1976"> <p>Post Driver</p> </td> <td data-bbox="1187 1832 1419 1976"> <p>Torque Head</p> </td> </tr> </tbody> </table>	<p>Post Driver</p>	<p>Torque Head</p>
<p>Post Driver</p>	<p>Torque Head</p>		

1. Extraction Drill

> Ø1.3 / Ø1.7 / Ø2.1 3가지로 구성되며 case에 따라 선택적으로 사용

Ø1.3 Drill

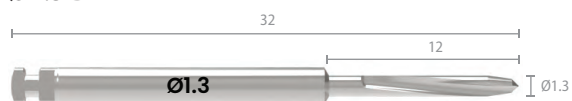

Code	KAAD13
------	--------

Ø1.7 Drill

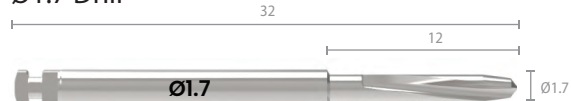

Code	KARD17
------	--------

Ø2.1 Drill



Code	KAMD21
------	--------

2. Extraction Screw

> Extraction Drill로 형성된 Hole에 나사방식으로 체결되며 잔존치아에 안정적으로 고정

> Ø1.8 / Ø2.2 / Ø2.6 3가지로 구성되며 Extraction Drill에 맞추어 선택 사용

> 근관치료가 되지 않은 Vital 치근은 Ø1.7 Drill 사용 후 Ø1.8 Screw 사용

Ø1.8 Screw



Code	KAAS16	* KAAS16X
------	--------	-----------

Length	10	15
--------	----	----

* Extra product



Ø2.2 Screw

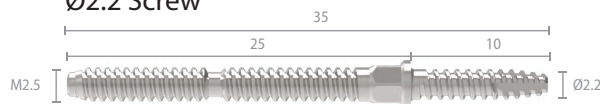

Code	KARS20	* KARS20X
------	--------	-----------

Length	10	15
--------	----	----

* Extra product

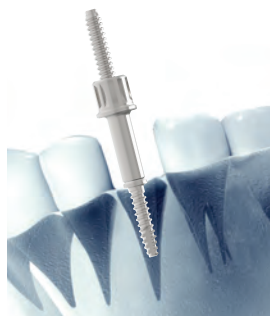

Ø2.6 Screw

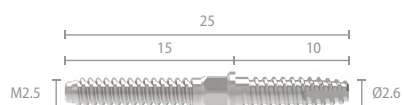

Code	KAMS25
------	--------



3. Post Driver

> Extraction Screw에 Post Driver 연결 후 Extraction Drill로 형성된 Hole에 Torque Wrench를 사용하여 시계방향으로 회전하여 고정
(권장 토크 : 최소 20Ncm~최대 35Ncm)

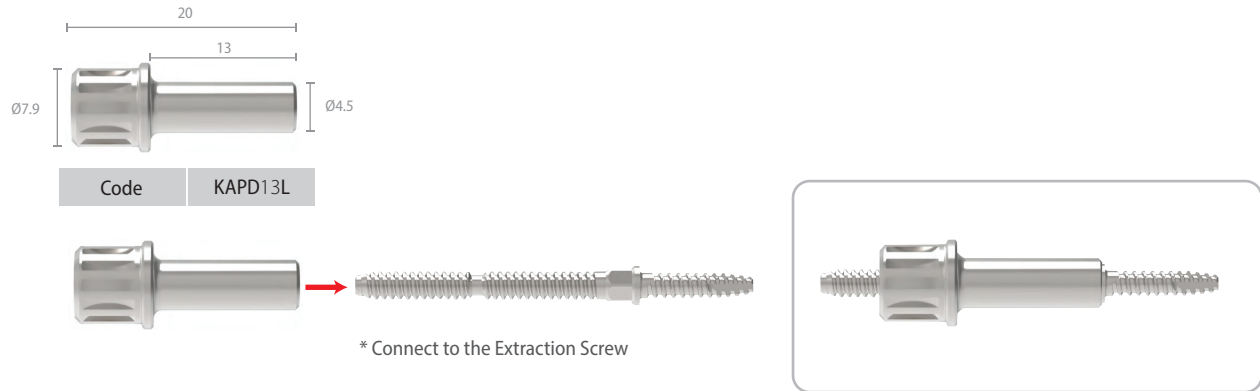

4. Rest Plate

> Extraction Screw와 Torque Head 사이에 연결되며 인접치아와 직접적으로 접촉되는 부분을 Silicon으로 보호함으로써 치아의 손상을 방지하며 Elevator 및 Torque Wrench가 사용될 수 있도록 지지대 역할
> 인접치아의 위치 및 거리에 따라 Extraction Screw의 위치를 조정할 수 있도록 5mm 간격으로 Hole 생성

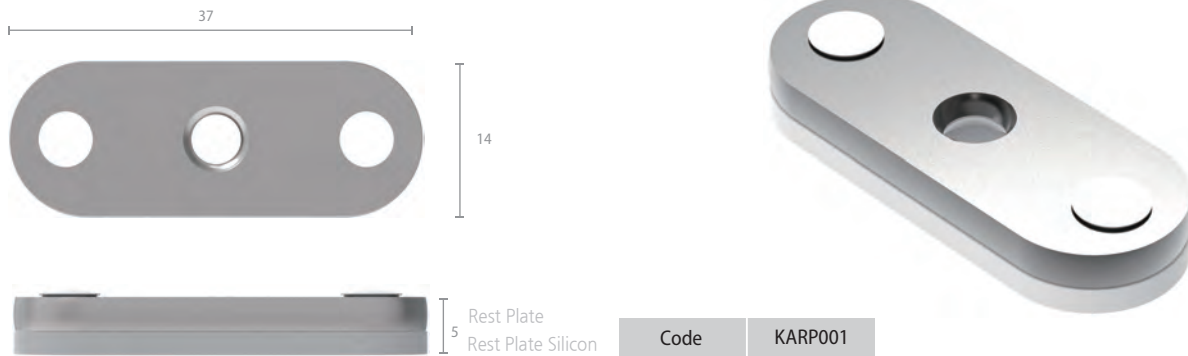

5. Torque Head

> 발치될 치아에 고정된 Extraction Screw와 체결되어 Rest Plate 사이를 고정시키며 Elevator와 함께 사용
> 발치될 치아의 인접치가 원심, 근심 모두 있을 경우 Torque Wrench를 사용하여 발치 (권장 토크 : 100Ncm 이하)



6. Elevator

> Torque Head와 연결하여 사용되며 원심 또는 근심 방향으로 힘을 가하여 발치

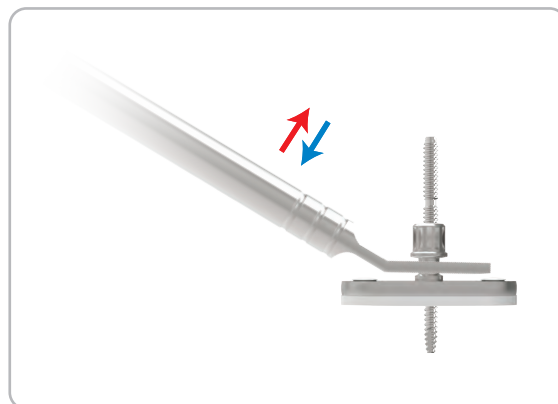
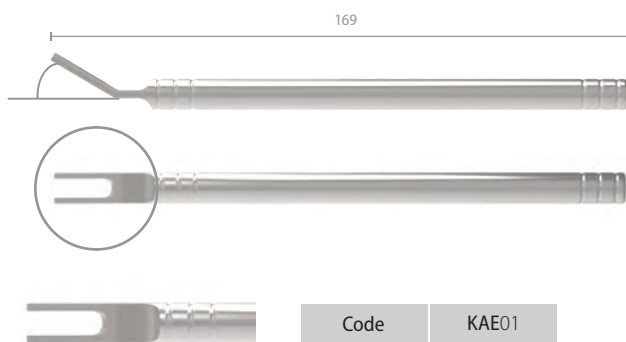

사용방법

1. Extraction Drill

발치할 치아에 Extraction Drill을 사용 하여 Hole 생성



Caution A

- Extraction Drill은 신경근관을 따라 Drilling
- Drill과 Screw가 치근을 관통해도 발치는 가능하므로 최소 10mm까지 충분히 Drilling

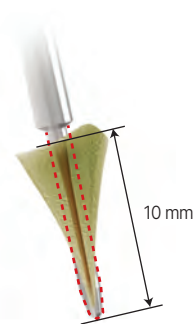

2. Extraction Screw

Post Driver에 Extraction Screw를 체결 후 생성된 Hole에 시계방향으로 회전하여 고정
(권장 체결 토크 : 최소 20Ncm~최대 35Ncm)



Caution B

- 10~12mm 깊이로 Drilling하여 10mm 깊이로 Extraction Screw 체결
- 20~25Ncm로 screw 고정

Post Driver에 Extraction Screw에 체결

* Drilling Sequence

근관 확장

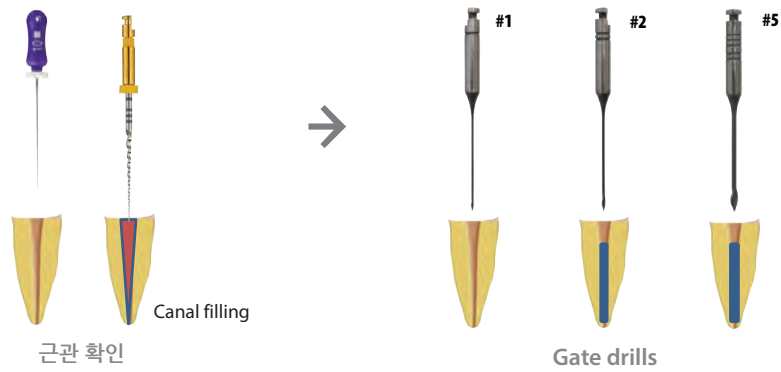

Atraumatic Extraction kit

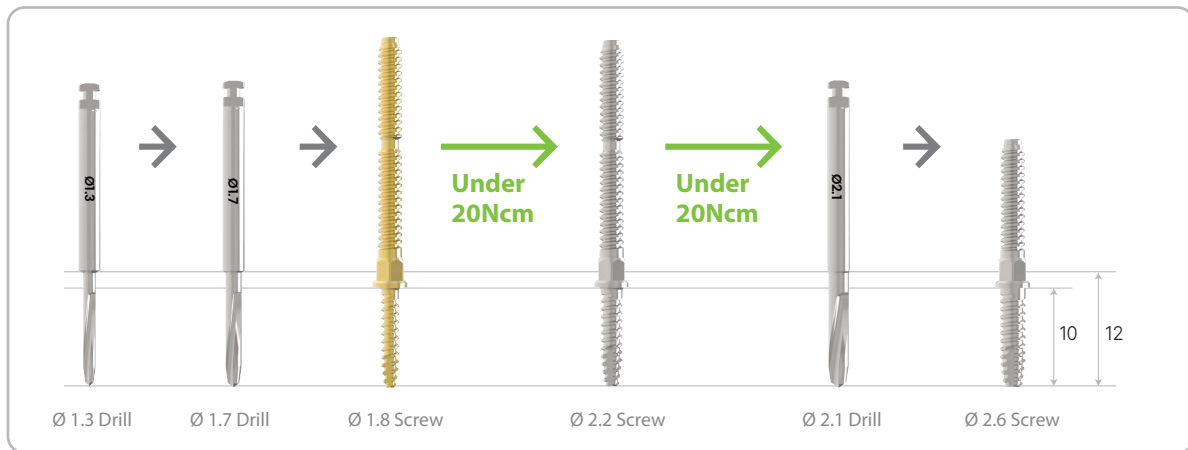

Caution C

- 20~25Ncm 토크력으로 Screw 고정 (부족한 경우에는 더 굵은 Screw 적용)
- 낮은 Torque는 발치 동안 Screw 탈락의 원인이 되고 과한 Torque는 치근 파절의 원인

3. Rest Plate

Post Driver을 제거 후, 인접 치아를 고려하여 Rest Plate를 Extraction Screw와 체결

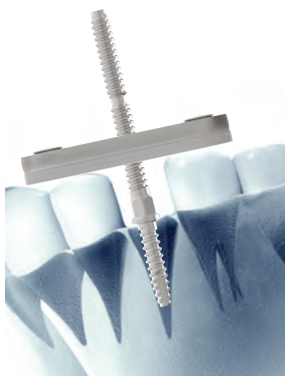

Rest Plate

4. Torque Head

Torque Head를 Rest Plate 위에 돌출된 Extraction Screw에 시계 방향으로 체결

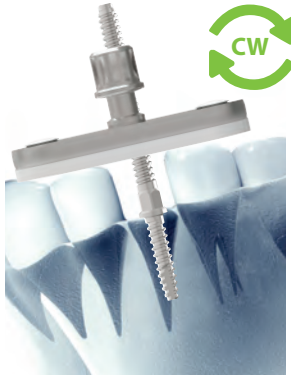

Torque Head를 Screw에 체결

5. Torque Wrench

Torque Wrench를 이용하여 Torque Head를 시계 방향으로 돌려 발치

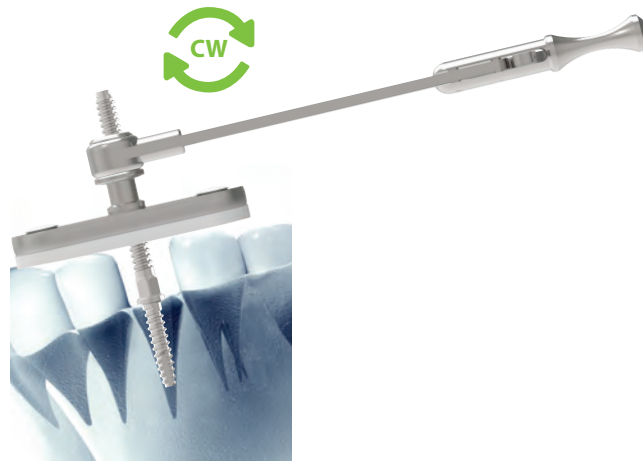

치근 발치

Caution D

- Torque Wrench를 이용한 발치는 근원심 치근이 존재하는 치아인 경우 사용

Caution E

- 동요도 2 이상의 인접 치아가 있는 경우, 발치 중에 힘을 받지 않도록 Elevator 이용
상방 견인이나 하방 가압으로 인접한 다른 치아에 힘이 작용

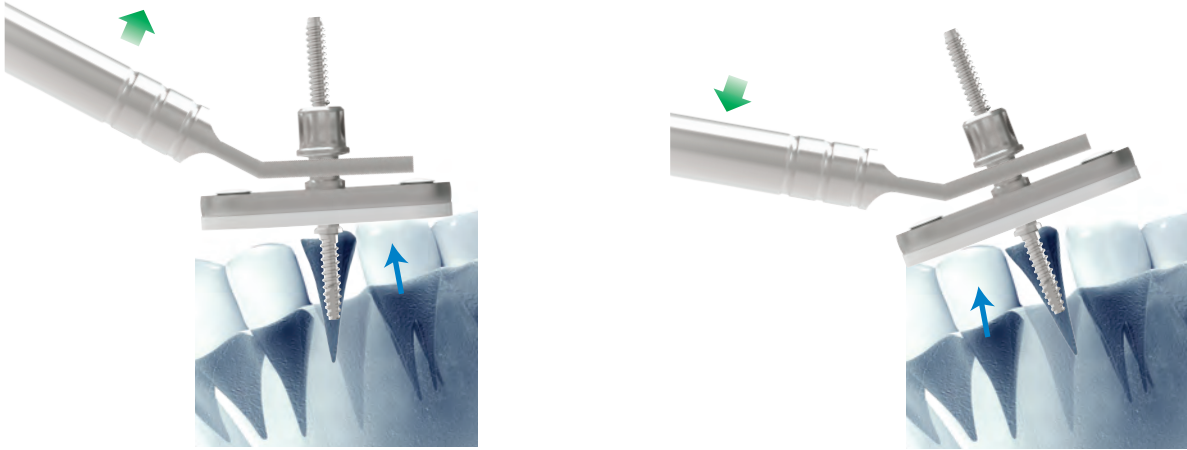

Caution F

- 인접한 치아가 근원심으로 하나가 빠져있는 경우는 Elevator 이용 발치

Expert Instruments

AO4 Surgical Stent [KDSS001]

> 임플란트 및 드릴의 위치 가이드

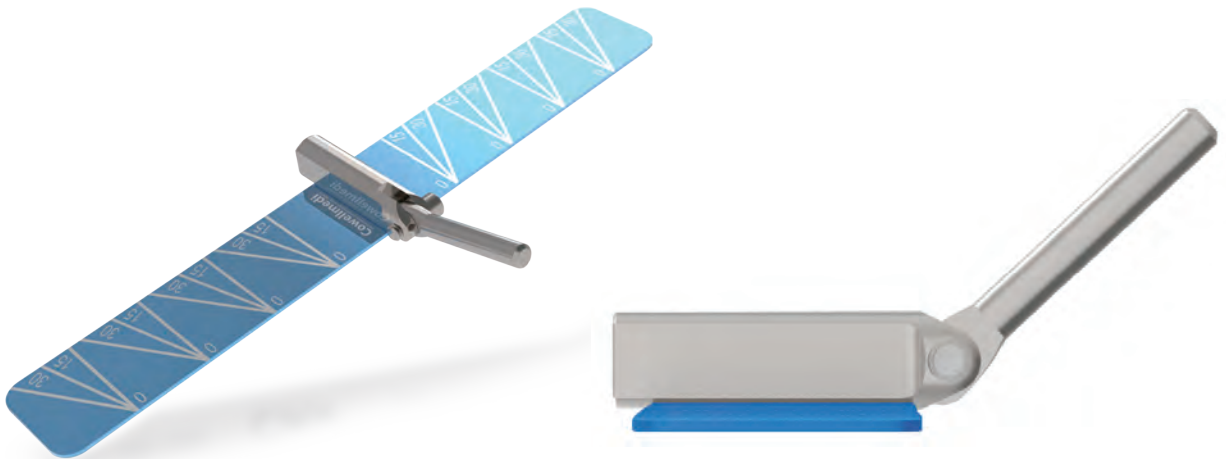
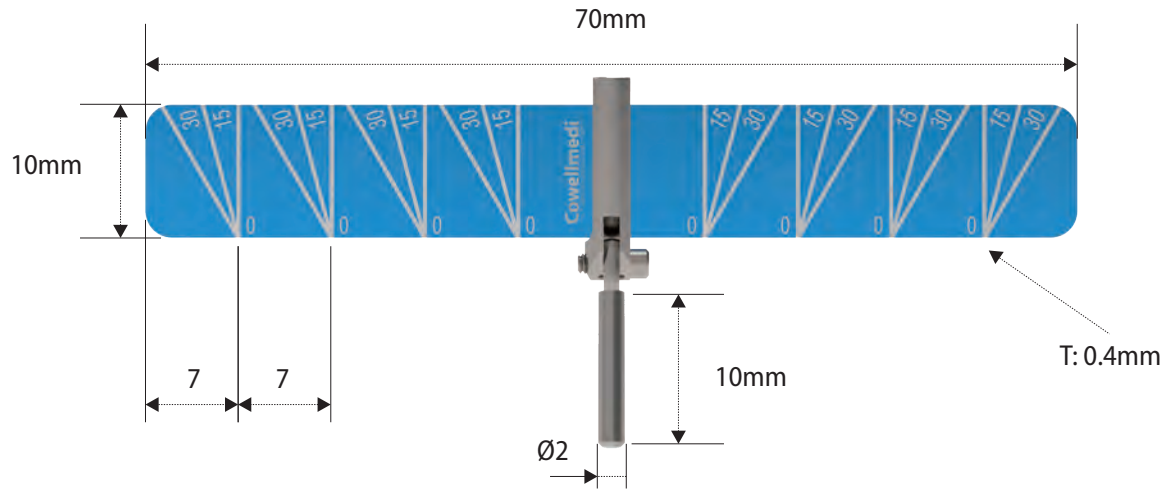

제품특징

- > 임플란트 식립 중 임플란트 및 드릴의 위치를 가이드
- > 시술의 안정성 및 정확성 향상 및 시간 단축
- > 건강한 치주의 손실을 최대한 방지하고, 치은의 회복 필요 없이 사전 제작된 보철 즉시 수복
- > 각도가 표시된 선으로 인해 좀 더 정확하고 예측 가능한 시술 가능

대상자

- > 무치악 환자
- > 시술 기간이 짧기를 희망하는 환자
- > 고혈압, 당뇨 등 성인병을 앓고 있는 환자
- > 정밀한 임플란트 시술이 필요한 환자

사용법

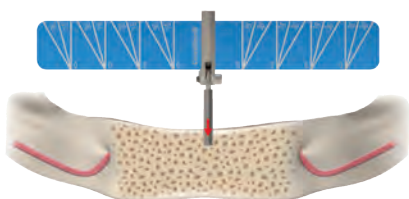

AO4 Surgical Stent 식립

- Flap 거상을 위한 절개
- AO4 Surgical Stent를 식립하기 위해 Ø2mm Twist Drill 사용
- * 이공의 위치 파악 필수

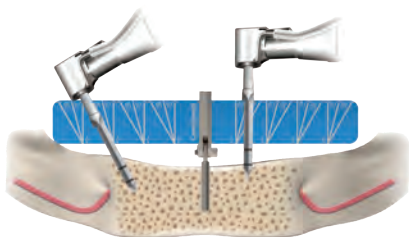

INNO Fixture 식립

- 각도가 표시된 선을 기준으로 Drilling해 INNO Fixture 식립

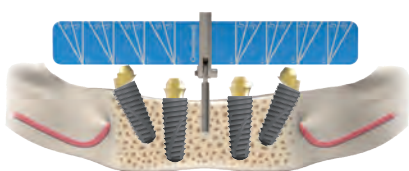

Multi S&A Abutment 체결

- INNO Fixture 식립 후, 위치에 따라 Multi S&A Abutment 체결
- * 구치부 : Multi A Abutment (30°) 식립
- * 전치부 : Multi A Abutment (15°) 식립 (보철 나사의 돌출 허용)

Volume-up Guide System

> 치은조직과 치조골을 자연 치아와 잇몸 형태로 형성하는 Implant 술식으로 Implant 시술을 한 부위에 식편압입 예방 또는 최소화

1. Volume-up Guide System의 장점

- > 치은조직과 치조골을 자연 치아와 잇몸 형태로 형성하는 Implant 술식으로 Implant 시술을 한 부위에 식편압입 예방 또는 최소화
- > COWELL BMP와 함께 사용 시 효과 극대화

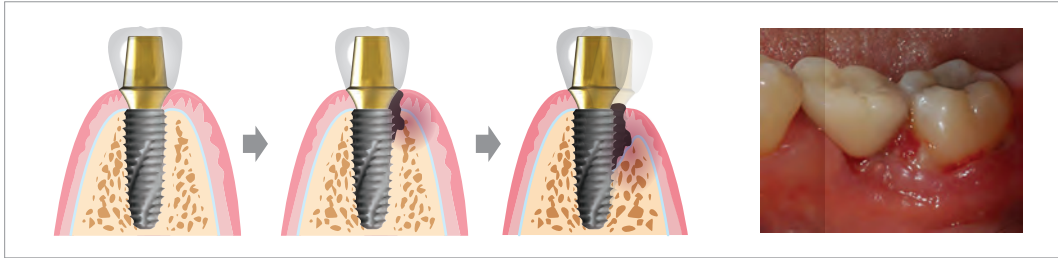

임플란트 주위염과 같은 합병증 없이 임플란트의 장기적인 성공을 위해서 이상적인 위치에 Fixture를 식립하여야 합니다. Fixture의 위치는 협측 치은 재생을 위하여 협측골로부터 최소 2mm 유지하며 치조골 재생을 위하여 3mm 아래 유지하여 치은 높이를 보존하는 것이 가장 효과적입니다.

협측 치은 보존을 위하여 협측골로부터 최소 2mm의 간격 유지
(Int J Periodontics Restorative Dent 2005)

치조골 재생을 위하여 최소 3mm 아래 유지하여 치은 높이 보존
(Clin Oral Implants Res 2000;11:1-11.)

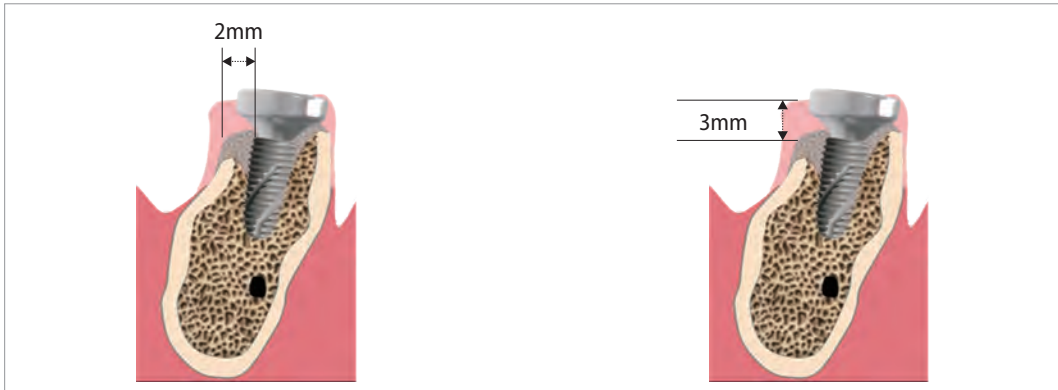

Volume-up Guide System은 앞서 언급한 2가지 임상적 요인에 따라 fixture를 정확한 위치에 식립할 수 있도록 도와주며, 정확한 Healing Abutment 직경을 사용한다면 치은 형성에 도움이 됩니다.

2. 제품 소개

Volume-up Gauge

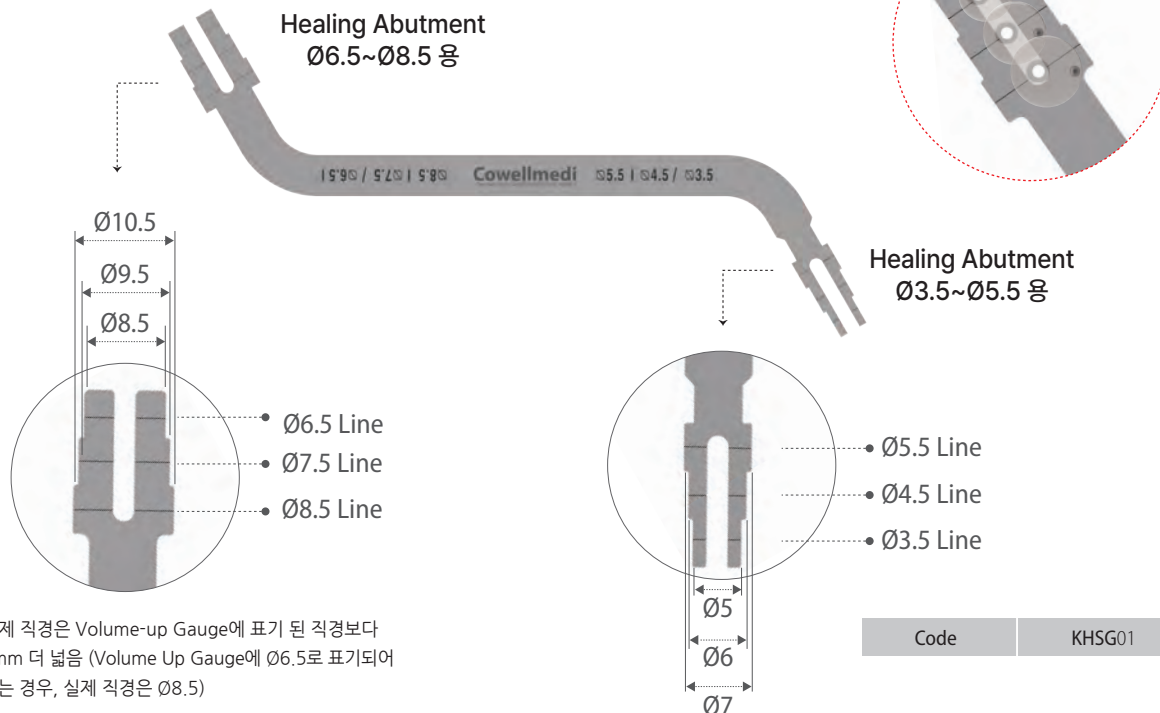

* 실제 직경은 Volume-up Gauge에 표기 된 직경보다 2mm 더 넓은 (Volume Up Gauge에 Ø6.5로 표기되어 있는 경우, 실제 직경은 Ø8.5)

- > 임플란트 보철의 치경부를 자연 치아의 폭경으로 유지하도록 임플란트 식립 위치 및 Healing Abutment 직경 선택할 수 있도록 안내
- > 연속된 발치부에서는 Volume Up Parallel Pin과 함께 사용
- > Point Drill과 함께 사용 (Ø2.1 mm 이하)
- > 구강 내 어느 방향에서도 레이저 마킹 확인 가능

Volume-up Parallel Pin

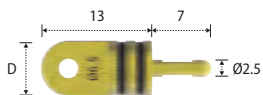

- > 연속된 발치부에서 Volume Up Gauge와 함께 사용
- > Ø3.5, Ø4.5 및 Ø5.5의 경우, Volume Up Parallel Pin 대신, Fixture 식립 후 Healing Abutment 체결



- 이탈 방지 구멍
Silk를 연결하여 구강 내 이탈 방지
- 직경 구분
직경별로 다른 전해 착색
- 잇몸 높이 표기
1~4mm cuff 표기
- 핀
Point Drill 후 생성 된 구멍에 꽂아 사용

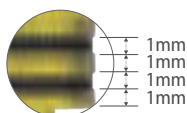

3. 사용방법

1. 1개만 식립하는 경우



Volume-up™ Gauge 를 Implant 식립부위에 위치하여 Healing Abutment 직경 확인



Volume-up™ Gauge 의 홈에 맞춰 Point Drill의 위치 파악

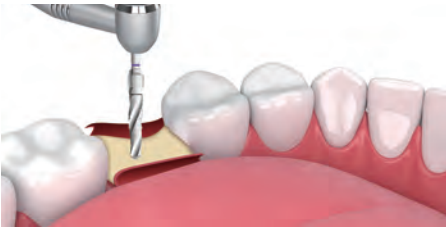

제조사 식립 순서에 맞춰 Drilling 후 Fixture 식립

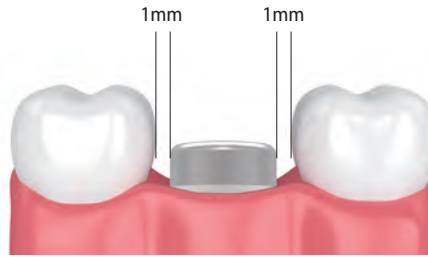

Torque 값이 20~30Ncm 이상일 경우, Healing Abutment 체결하며, 이하일 경우 Cover Screw 체결 후 일차 봉합

2. 연속된 발치부에 2개 이상 식립하는 경우



Volume-up™ Gauge 를 위치시킨 뒤 Point Drill 위치 파악



Point Drill 후 생긴 구멍에 Volume-up™ Parallel Pin을 끼움



이전 단계와 동일하게 진행

4. 임상 증례

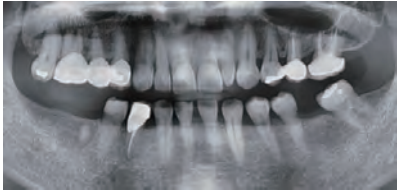

술전파노라마



술 전



Volume Up Gauge로 직경 확인 (Ø8.5)



Volume Up Gauge홈에 맞춰 Point Drill위치



Point Drill후 생성된 구멍에 Ø8.5 Volume UP Parallel Pin을 끼움



이 후, 앞의 임플란트 위치에 맞춰 위치 시켜 직경 확인(Ø7.5)



Volume Up Gauge홈에 맞춰 Point Drill위치



Point Drill후 생성된 구멍에 Ø7.5 Volume UP Parallel Pin을 끼움



제조사사의 식립 순서에 맞춰 Drilling 후 Fixture 식립



Fixture에 Volume Up Healing Abutment 체결



Easy Seal등과 같은 수복재로 screw hole을 충전



술 후 파노라마

COWELL REGENERATIVE SOLUTION

Inspire confidence through a comprehensive approach



COWELL BMP

세계 최초로 상품화 된 E.rhBMP-2 성장인자 기반 골이식재로 Soft 및 Hard Tissue 재생에 탁월한 역할을 하며 10년 이상의 임상으로 효능과 안전성이 검증된 프리미엄 골이식재

INNO-CaP

인산칼슘으로 구성된 골전도력을 지닌 완전 흡수성 재료로 Vital Bone 전환력이 우수



COWELL BMP / INNO-CaP / InnoGraft B

**COWELL
REGENERATIVE
SOLUTION**

InnoGraft B

골 용화를 촉진하고 빠른 혈액 침투 및 흡수로 높은 인체친화성을 보이는 인체의 골과 가장 유사한 골이식재 (100% 소 해면골)



InnoGenic PTFE-Mesh

기공이 없는 비흡수성 차폐막으로 세균 침투 방어에 탁월하며 Open Membrane Technique에 최적화



InnoGenic Wifi-Mesh

티타늄 프레임이 보강된 비흡수성 차폐막으로 세균 독소 침투를 방지하고 외부압력에도 뛰어난 형상 유지력을 가지고 여러 종류의 임상증례에 적용할 수 있도록 다양한 형태 제공



BTP1424AA



BTP1424AB



BTP1525BB



BTP1725CA
BTP1725CA12



BTP2030AB
BTP2030AB12



BTP2530AB
BTP2530AB15



BTP3040AB
BTP3040AB15

InnoGenic Wifi-Mesh & PTFE-Mesh

10년의 성과, 미래의 변화

코웰BMP

골유도성 골이식재 rhBMP-2 + BCP



세계 최초로 개발된 E.rhBMP-2 (E.Coli derived Recombinant Human Bone Morphogenetic Protein type 2)는 성장인자로서 뼈와 연골 형성을 유도하며, 골아 세포 분화에 중요한 역할을 하는 레티노이드 매개체입니다.

구성

- COWELL BMP는 세계 최초로 개발된 E.rhBMP-2 골이식재입니다.
- 10년의 기간 동안 다양한 임상례를 기반으로 40개 이상의 연구가 진행되었습니다.
- BCP는 Carrier로서 공간을 유지관리 합니다.

특징

- 골재생을 위한 연조직의 Primary closure 불필요
- 부착치는 재생
- 어려운 골이식술과 연조직 재생술을 쉽게 시술
- 출기세포에 직접 작용
- Extraction socket에 감염 없이 골재생 유도
- BMP 1g 당 입자 1mg 포함 (자가골은 1g 당 2ng 포함)

10년의 성과, 미래의 변화

개발 배경

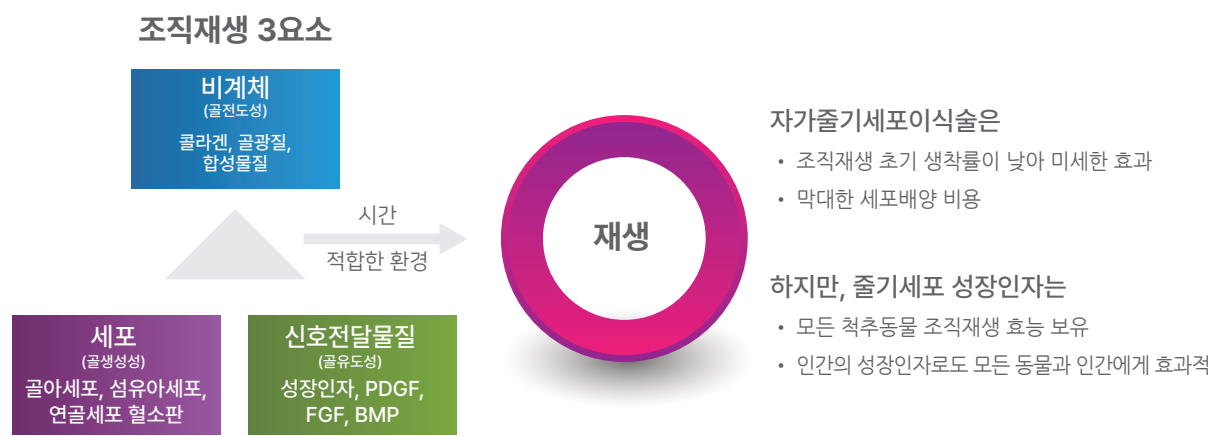

줄기세포 이식술 VS rhBMP-2



10년의 성과, 미래의 변화

GBR 주요 인자

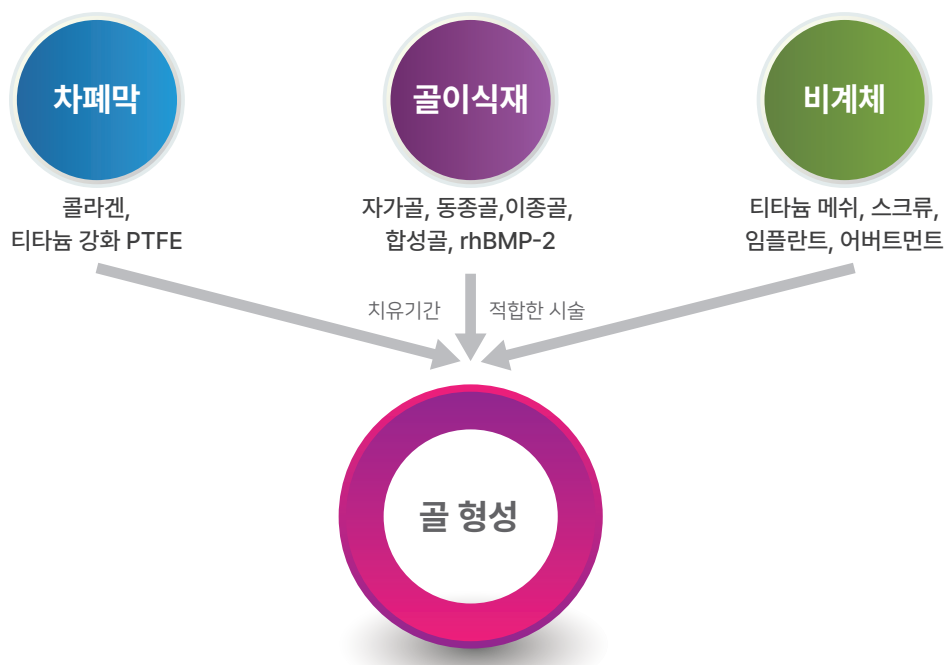

rhBMP-2 줄기세포 작용기전

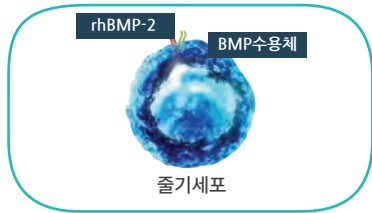

1. rhBMP-2가 줄기세포의 BMP-2 수용체와 결합하여 핵의 DNA 활동 개시

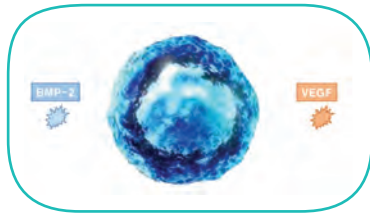

2. 줄기세포의 BMP-2와 VEGF가 작용하여 단백질 합성 및 분비
* VEGF : 관내피성장유전자

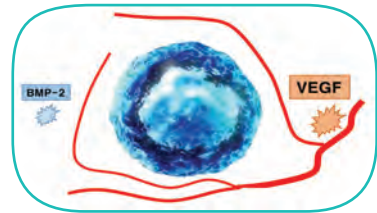

3. VEGF는 줄기세포에 필요한 영양을 공급 할 신생 혈관을 만들어 세포 성장

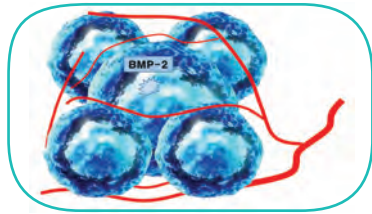

4. BMP-2는 주변 줄기세포가 세포 분열하여 빠르게 증식하도록 촉진

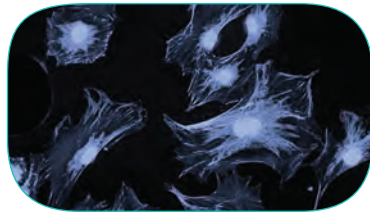

5. 증식된 줄기세포는 주변 조직에 맞춰 다양한 세포로 분화

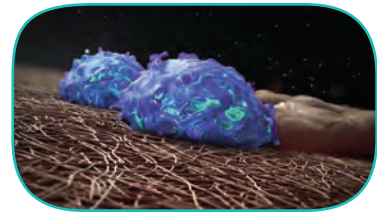

6. 분화 된 세포가 신생 조직을 형성하고 주변 환경에 따라 신생 조직 재형성진

코웰BMP 사용법



1. 코웰BMP 용기 내 골이식재를 본디쉬에 담음

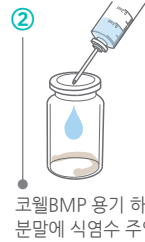

2. 코웰BMP 용기 하단 rhBMP-2 분말에 식염수 주입 *



3. rhBMP-2 분말 10초 용해

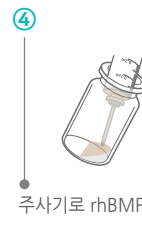

4. 주사기로 rhBMP-2 용액 흡입

* 혼합 배율	
코웰BMP	식염수
0.1mg	0.1ml
0.25mg	0.2ml
0.5mg	0.4ml

1. 골이식재와 혼합

골이식 직전 이식재에 적셔서 이식하여 rhBMP-2 단백질이 골이식재 칼슘 성분에 흡착되는 시간을 최소화

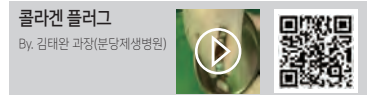
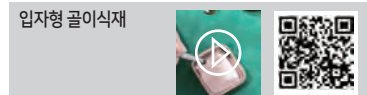

2. 골이식부 주입

주입 후 용액이 치은 밖으로 흘러 나오더라도 이식부 줄기세포에는 최소 유효약 효용량에 도달되므로 효과는 동일

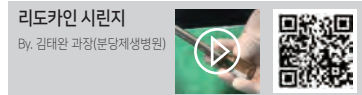
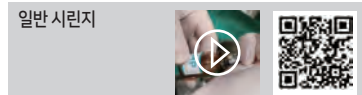

3. 코웰BMP 코팅 임플란트

임플란트에 용액을 직접 코팅한 후 식립하여 골수의 줄기세포를 직접 활성화 시킴

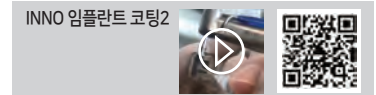

* 위 QR 코드를 스캔하시면 코웰BMP 사용 영상을 확인하실 수 있습니다.

0.1g	
Product code	Particle size
BB1010	0.41~1.0mm

0.25g	
Product code	Particle size
BB1025	0.41~1.0mm

0.5g	
Product code	Particle size
BB1050	0.41~10mm

코웰BMP의 안전성

Q : rhBMP-2 사용으로 골 과성장 우려?

A : 골형성 기간이 완료되면 줄기세포에서 Twist-2가 합성되어 세포분화가 정지하도록 하는 기전을 가지기 때문에 안전합니다.

Q : rhBMP-2 사용량과 원발성 발암의 연관성?

A : 일반적으로 rhBMP-2가 발암의 원인이 되는 경우는 40mg 이상 사용 시 입니다.
수 많은 연구를 통해 검증된 rhBMP-2의 안전한 용량의 기준은 4.2~8.4mg이며, 코웰BMP 0.25g에는 0.25mg의 rhBMP-2가 있어 안전 용량 기준보다 약 15~30배 낮아 안전합니다.

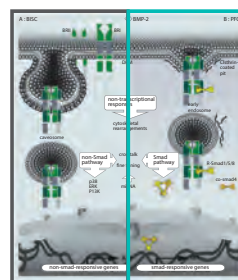
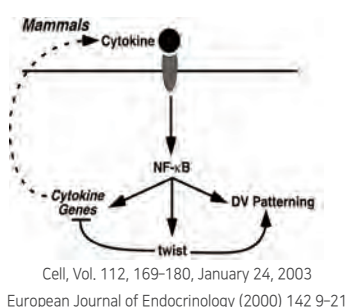

- 수용체에 결합
- 세포내 신호전달 체계
- 세포 핵 이동
- VEGF, BMP 합성 개시

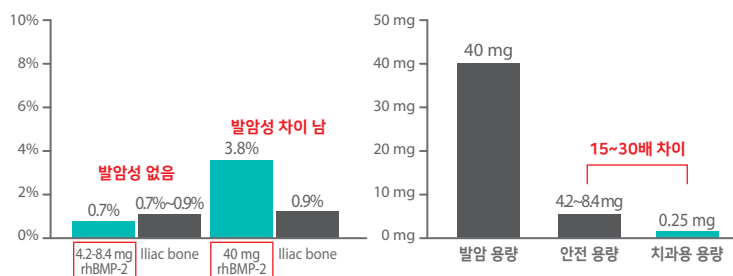

Q : rhBMP-2 사용으로 인한 부종 발생?

A : 이완 절개로 rhBMP-2가 근육 내 신생혈관을 증식시켜 부종이 생기는 경우가 있으나, 통증은 없습니다.
또한, 부종은 일시적으로 나타나는 현상이므로 안전합니다.

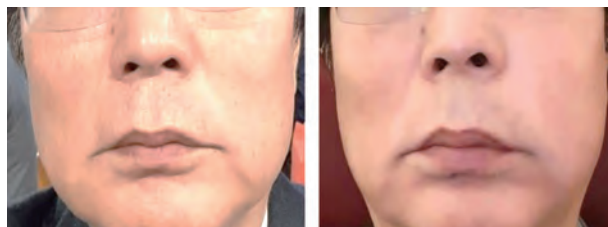

Q : rhBMP-2 사용으로 인한 점액종 발생?

A : 상악동 거상술 후 rhBMP-2에 의한 치유과정에서 과량 분비되는 삼출액은 밀폐된 상악동 골이식부에 저류되어 점액종으로 발전하지만 사라집니다.
다량의 rhBMP-2를 사용하기 보다 최대 0.25mg으로 사용량을 제한한다면 안전합니다.

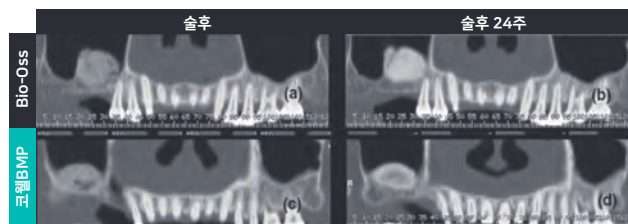

코웰BMP의 유효성

치명 결점 모형 골 이식재 종류

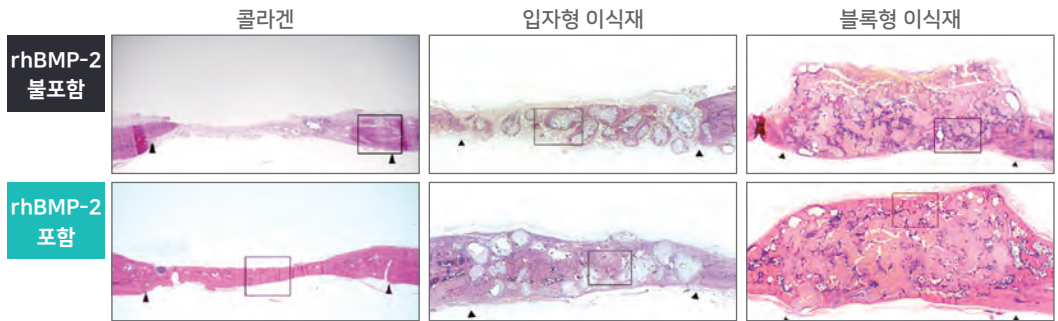

rhBMP-2로 코팅한 임플란트 수직 결손

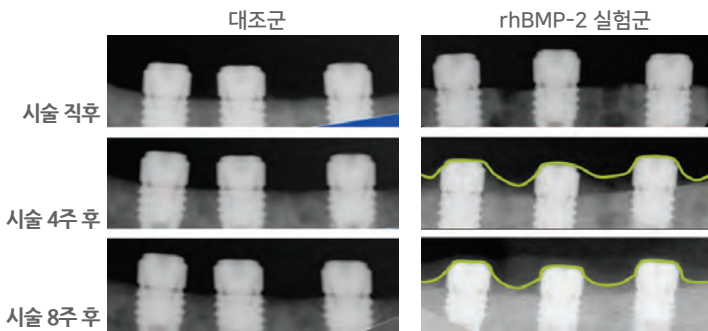

rhBMP-2로 코팅한 임플란트 열개 결손

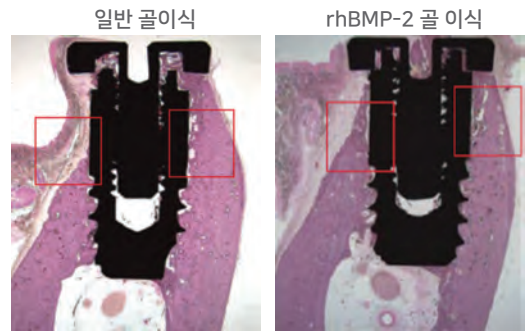

* rhBMP-2 골이식 후 차폐막을 사용하지 않아도 안전한 골재생이 이루어지는 반면, 일반 골이식재 사용 시 차폐막 사용 필수

이식재 종류 별 비

* 피로인산칼슘, CPP(Ca/P=1)가 BCP(Ca/P=1.55)보다 흡수율이 높은 양상

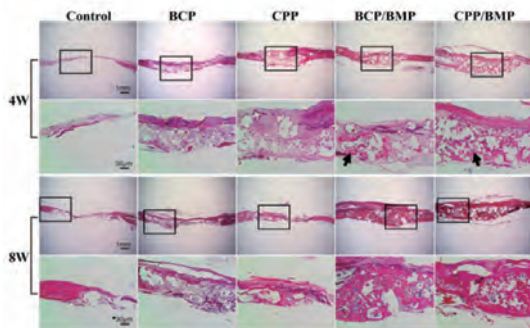

* 피로인산칼슘, CPP(Ca/P=1)가 BCP(Ca/P=1.55)보다 초기에 골 재생되는 효과 확인

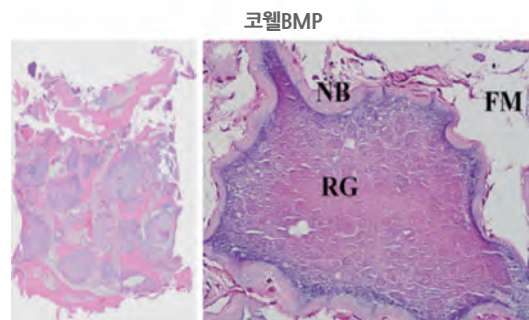
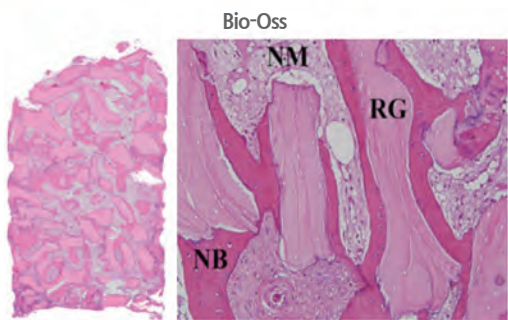
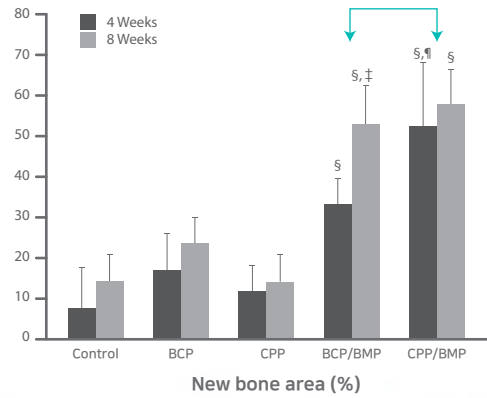

신생골 생성비율은 차이가 없고 Bio-Oss에는 입자 사이에 단단한 섬유조직으로 구성되지만 코웰BMP는 골수 조직이 채워집니다. 따라서 Bio-Oss는 골이식부에 드릴 중 저항이 높고 코웰BMP는 골수에 의한 골재형성이 우수합니다.

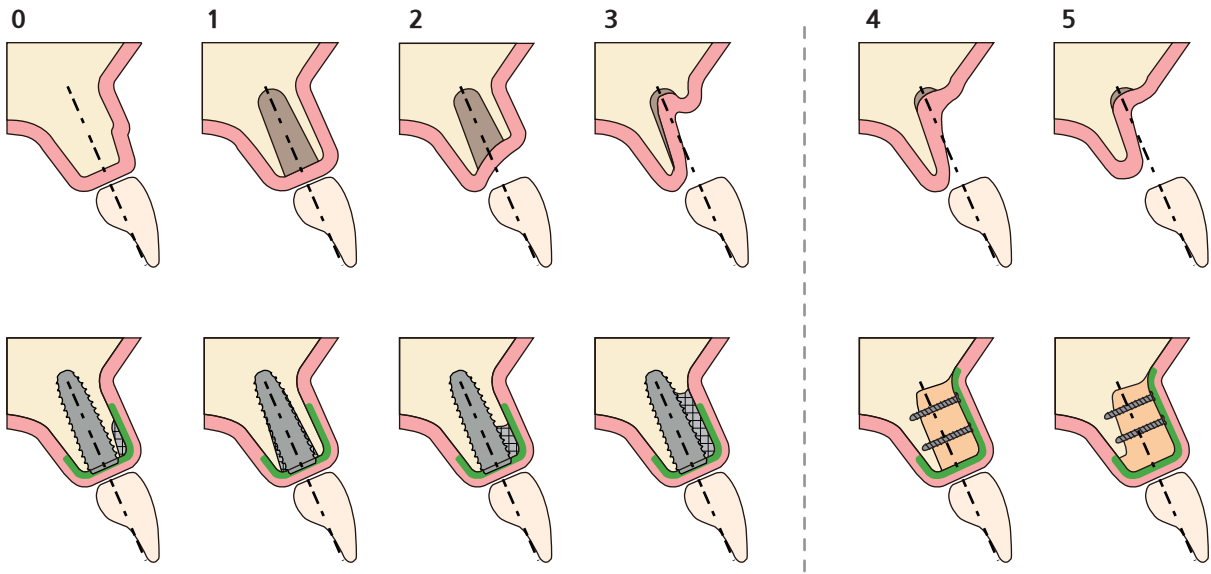

차폐막이 필요한 GBR 방식의 수평 골 증대술

Goran I Benic, Christoph Hans Franz Hämmerle

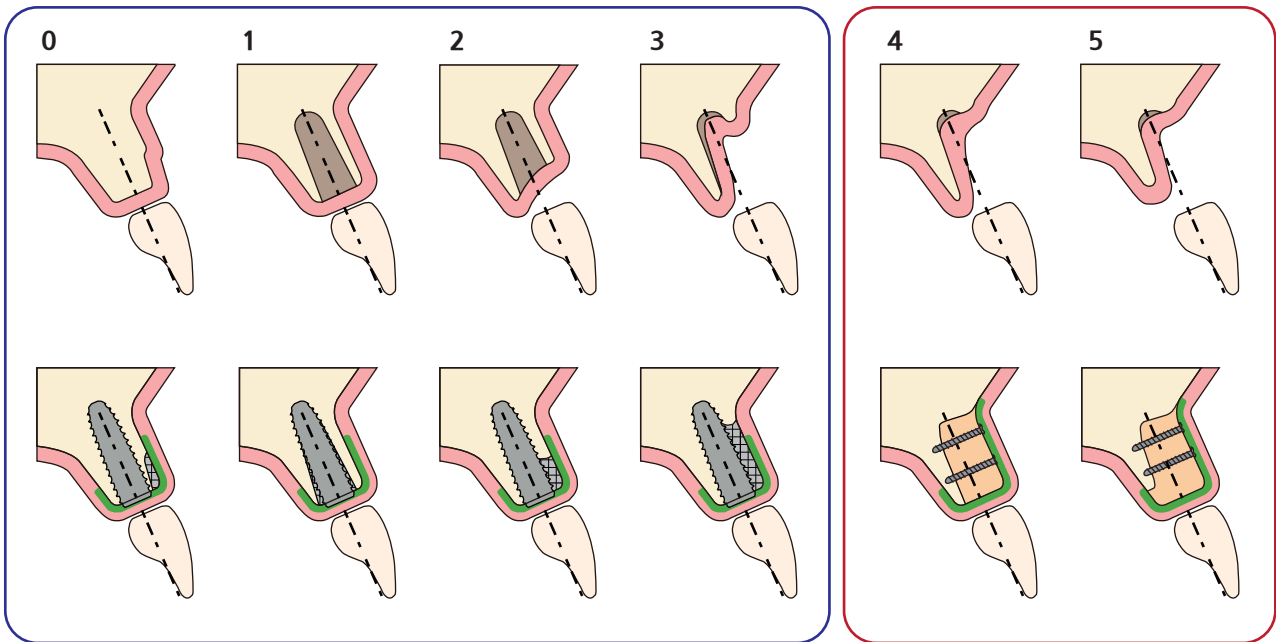

차폐막이 불필요한 코웰BMP 수평 골 증대술

입자형 골이식재와 Wifi-Mesh



코웰BMP를 활용한 수직 및 수평 골증대술



술전 측면

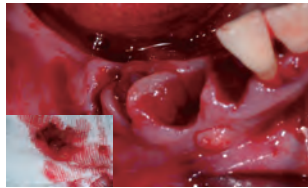

발치 및 염증 조직 제거

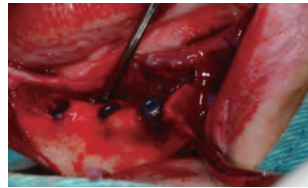

#45, 46, 47 임플란트 식립

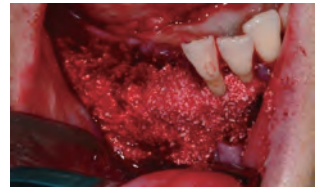

동종골 및 합성골이식으로
수평 및 수직 골증대



코웰BMP 주입

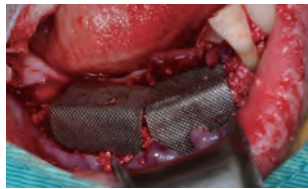

Ti-Mesh 이식

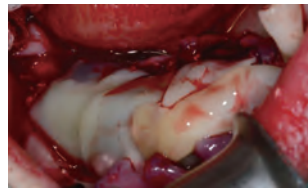

CGF로 차폐

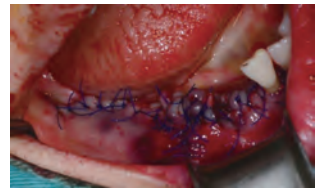

1차 봉합

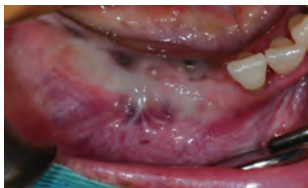

2차 술전



Ti-Mesh 제거

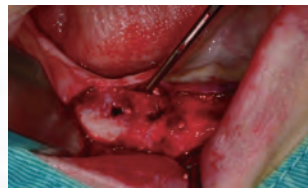

#45, 46, 47 2차 수술

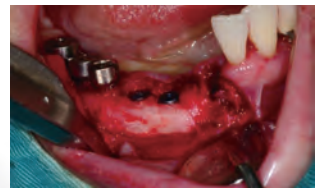

#41, 43, 44 임플란트 식립

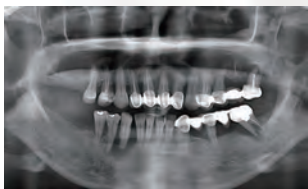

술전 파노라마



보철 후 파노라마



술후 8년 파노라마

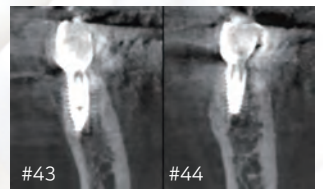

#43

#44

술후 8년 CT



코웰BMP를 활용한 골 및 치은 재생술



술전 측면

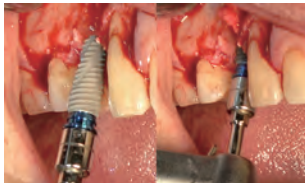

INNO 임플란트 식립

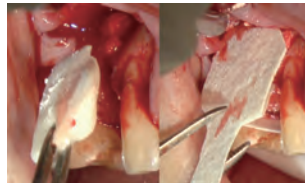

코웰BMP BCP 파우더를 문힌
2겹의 멤브레인 이식



코웰BMP 주입



술후 측면



술후 1개월 측면



술후 4개월 임시치아 제거



임시치아 제거 후 2주



최종 보철 후 5개월 측면



최종 보철 후 5개월 교합면



술전 (18. 08. 02)



술후 (18. 08. 02)

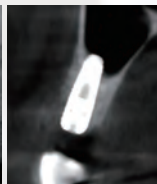

술후 4개월
(18. 12. 03)



술후 1년
(19. 08. 06)

코웰BMP 임상 논문

- 1 Analysis of hydrolyzable polyethylene glycol hydrogels and deproteinized bone mineral as delivery systems for glycosylated and non-glycosylated bone morphogenetic protein-2. *Acta Biomater.* 2012 Jan;8(1):116-23.
- 2 Effects of rhBMP-2 Coating Tricalcium Phosphate on Socket Preservation in Dog Extraction Socket. *Tissue Engineering and Regenerative Medicine*, Vol. 5, No. 4-6, pp 637-642 (2008)
- 3 Effects of Polycaprolactone-Tricalcium Phosphate, Recombinant Human Bone Morphogenetic Protein-2 and Dog Mesenchymal Stem Cells on Bone Formation: Pilot Study in Dogs. *Yonsei Med J* 50(6): 825-831, (2009).
- 4 The induction of bone formation in rat calvarial defects and subcutaneous tissues by recombinant human BMP-2, produced in *Escherichia coli*. *Biomaterials* 31 (2010) 3512-3519.
- 5 Alveolar ridge augmentation using anodized implants coated with *Escherichia coli*-derived recombinant human bone morphogenetic protein 2. *Oral Surg Oral Med Oral Pathol Oral Radiol Endod.* (2011) Jul;112(1):42-9.
- 6 Bone formation of *Escherichia coli* expressed rhBMP-2 on absorbable collagen block in rat calvarial defects. *Oral Surg Oral Med Oral Pathol Oral Radiol Endod* 2011;111:298-305.
- 7 Bone formation of block and particulated biphasic calcium phosphate lyophilized with *Escherichia coli*-derived recombinant human bone morphogenetic protein 2 in rat calvarial defects. *Oral Surg Oral Med Oral Pathol Oral Radiol Endod* 2011;112:298-306.
- 8 Induction of bone formation by *Escherichia coli*-expressed recombinant human bone morphogenetic protein-2 using block-type macroporous biphasic calcium phosphate in orthotopic and ectopic rat models. *J Periodontol Res.* (2011) Dec; 46(6):682-90.
- 9 Enhanced adipogenic differentiation and reduced collagen synthesis induced by human periodontal ligament stem cells might underlie the negative effect of recombinant human bone morphogenetic protein-2 on periodontal regeneration. *J Periodontol Res* (2011); 46: 193-203.
- 10 The Effects of rhBMP-2 Injection at Distraction Osteogenesis of Rats' Tibia. *Tissue Engineering and Regenerative Medicine*, Vol. 8, No. 2, pp 158-163 (2011).
- 11 Discontinuous Release of Bone Morphogenetic Protein-2 Loaded Within Interconnected Pores of Honeycomb-Like Polycaprolactone Scaffold Promotes Bone Healing in a Large Bone Defect of Rabbit Ulna. *Tissue Eng Part A.* 2011 Oct;17(19-20):2389-97.
- 12 The effect of immobilization of heparin and bone morphogenetic protein-2 to bovine bone substitute on osteoblast-like cell's function. *J Adv Prosthodont* 2011; 3:145-51.
- 13 Multicenter, randomized clinical trial on the efficacy and safety of *Escherichia coli*-derived rhBMP-2 with β -Tricalcium phosphate and hydroxyapatite in human extraction sockets. *J Adv Prosthodont* 2011; 4:178-182.
- 14 Effects of Anodized Implants Coated With *Escherichia coli*-Derived Recombinant Human Bone Morphogenetic Protein-2 on Osseointegration in Rabbits. *Tissue Engineering and Regenerative Medicine*, Vol. 8, No. 1, pp 62-68 (2011).
- 15 Novel analysis model for implant osseointegration using ectopic bone formation via the recombinant human bone morphogenetic protein-2/macroporous biphasic calcium phosphate block system in rats: a proof-of concept study. *J Periodontol Implant Sci* 2012; 42:136-143.
- 16 Effects of anodized implants coated with *Escherichia coli*-derived rhBMP-2 in beagle dogs. *Int. J. Oral Maxillofac. Surg.* 2012; 41: 1577-1584.
- 17 Bone formation of middle ear cavity using biphasic calcium phosphate lyophilized with *Escherichia coli*-derived recombinant human bone morphogenetic protein 2 using animal model. *International Journal of Pediatric Otorhinolaryngology* 77 (2013) 1430-1433.
- 18 Bone formation and remodeling of three different dental implant surfaces with *Escherichia coli*-derived recombinant human bone morphogenetic protein 2 in a rabbit model. *Int J Oral Maxillofac Implants.* 2013; 28(2):424-30.
- 19 Recombinant Human Bone Morphogenetic Protein-2 Stimulates the Osteogenic Potential of the Schneiderian Membrane: A Histometric Analysis in Rabbits. *Tissue Eng Part A.* 2013 Sep;19(17-18):1994-2004.
- 20 The effect of anodized implants coated with combined rhBMP-2 and recombinant human vascular endothelial growth factors on vertical bone regeneration in the marginal portion of the peri-implant. *Oral Surg Oral Med Oral Pathol Oral Radiol* 2013;115:e24-e31.
- 21 Sinus augmentation using BMP-2 in a bovine hydroxyapatite/collagen carrier in dogs. *J Clin Periodontol* 2014; 41: 86-93.
- 22 Low-Dose Recombinant Human Bone Morphogenetic Protein-2 to Enhance the Osteogenic Potential of the Schneiderian Membrane in the Early Healing Phase: In Vitro and In Vivo Studies. *J Oral Maxillofac Surg* 72:1480-1494, 2014.
- 23 Prospective randomized, controlled trial of sinus grafting using *Escherichia coli*-produced rhBMP-2 with a biphasic calcium phosphate carrier compared to deproteinized bovine bone. *Clin Oral Implants Res.* 2015 Dec;26(12):1361-8.
- 24 Controlled release of BMP-2 using a heparin-conjugated carrier system reduces in vivo adipose tissue formation. *J Biomed Mater Res A.* 2015 Feb;103(2):545-54.
- 25 The efficacy of BMP-2 preloaded on bone substitute or hydrogel for bone regeneration at peri-implant defects in dogs. *Clin Oral Implants Res.* 2015 Dec;26(12):1456-65.
- 26 Effect of rhBMP-2 Immobilized Anorganic Bovine Bone Matrix on Bone Regeneration. *Int. J. Mol. Sci.* 2015, 16, 16034-16052.
- 27 Effects of rhBMP-2 on Sandblasted and Acid Etched Titanium Implant Surfaces on Bone Regeneration and Osseointegration: Split-Mouth Designed Pilot Study. *Biomed Res Int.* 2015; 2015:459393.
- 28 Comparison of collagen membrane and bone substitute as a carrier for rhBMP-2 in lateral onlay graft. *Clin Oral Implants Res.* 2015;26(1):e13-9.
- 29 Effects of BMP-2 Delivery in Calcium Phosphate Bone Graft Materials with Different Compositions on Bone Regeneration. *Materials* 2016, 9, 954.
- 30 Source and Carrier Effect on the Bioactivity of BMP Bio-Implants. *Master of Science* 2013. Sylvie Di Lullo 2013, Faculty of Dentistry, University of Toronto.
- 31 Soft and hard tissue changes when socket preservation using rhBMP-2, PRP and Non-Resorbable dPTFE membrane. *Dental Implant Journal: Vol. 3, May, 2014.*
- 32 The effect of rhBMP-2 bonegraft on infrabony defects. *Dental Implant Journal: Vol. 3, May, 2014.*

COWELL BMP

Q & A

Q1. COWELL BMP 이식재를 사용할 경우 차폐막을 반드시 사용해야 하는가?

Answer : 차폐막을 사용하면 골이식재와 연조직 간의 경계면이 확연히 구별되는 장점을 가집니다. 하지만, BMP는 골조직의 골아세포 뿐만 아니라 연조직의 섬유아세포도 직접 성장시키므로 골이식 후, 1주일 이 지나면 골이식 부위에 신생 골막이 재생됩니다. 따라서, 차폐막이 없어도 골조직은 재생됩니다.

Q2. COWELL BMP를 타 이식재와 혼용하여 사용해도 되는가?

Answer : COWELL BMP는 Bio-oss와의 혼용에서 우수한 임상결과를 보이고 있습니다. COWELL BMP는 추가로 타 골이식재를 사용할 수도 있습니다. 추가 사용 용량은 이식부위를 봉합한 상태에서 비엠피 주사용수로 주입하는 경우에는 최대 5배까지 가능하였습니다. 그러나 이식재와 혼합한 상태에서는 두 배까지 효능이 있다고 보고되고 있습니다.

Q3. 자가골을 대신해서 사용할 수 있는가?

Answer : COWELL BMP의 성장인자가 줄기세포를 자극하여 골형성을 촉진하는데 탁월한 효과가 있습니다. 따라서 자가골 대체 효과가 있습니다. 하지만, COWELL BMP 이식재 자체에 줄기세포가 포함된 것이 아니기 때문에 광범위한 결손부나 블랙본 이식이 필요한 부분에는 자가골과 혼용하면 최상의 결과를 얻을 수 있습니다.

Q4. COWELL BMP를 과다 사용시에 부작용이 있는가?

Answer : 미국 정형외과에서는 BMP 50mg 이상을 투입하는 경우에서 술 후 부종과 통증이 보고되고 있습니다. 그러나 그 이하 사용량에서는 자가골 채취로 인한 통증보다는 훨씬 적다고 합니다. 치과영역에서는 최대 5mg을 사용하므로 안전하다고 할 수 있습니다.

미국 제품처럼 콜라겐 스펀지에 다량의 BMP를 함께 사용하는 경우에는 중심부에 단백질이 응축되면서 Seroma가 나타날 수 있습니다. COWELL BMP에서는 콜라겐 스펀지를 사용하지 않으므로 이러한 현상은 나타나지 않습니다.

Q5. COWELL BMP 시술법에서 Open Sheet Technique을 하는 이유는 무엇인가?

Answer : 일반 골이식술에서 골조직 재생의 조건으로 가장 중요한 것은 주변 치은조직으로 완전히 덮어서 수 개월간 유지해야 한다는 것입니다. COWELL BMP는 연조직을 재생하는 능력을 가지고 있으므로 연조직이 완전 폐쇄되지 않더라도 3주만에 신생 치은조직으로 덮혀집니다. 따라서 그 동안 골이식재가 빠져나가지 않도록 Sheet로 덮어주는 것을 권장합니다. 다만 급성 염증이 수반된 경우에는 감염의 우려가 있으므로 지연 골이식술을 권장합니다.

INNO-CaP

Calcium Phosphate , Synthetic Bone Graft

골전도성 흡수성 합성골 이식재 (Osteoconductive resorbable synthetic bone graft material)

- > 인산칼슘으로 구성된 골전도능력(Osteoconductivity)을 지닌 흡수성(Resorbable)재료
- > 골결손부에 채워 넣으면 신생골이 형성될 공간(Void Cavity)을 보존하여 뼈의 형태를 유지하며, 서서히 흡수되어 뼈로 대체

우수한 생체적합성과 골전도성

- > 인체골 성분인 인산칼슘으로 구성된 흡수성(Resorbable) 골이식재로서 생체적합성이 우수하며 골전도성이 뛰어나
- > 순수합성골로서 동종골, 이종골과는 달리 질병 전염의 위험성이 없음

Cell 배양 SEM 사진 (14일)

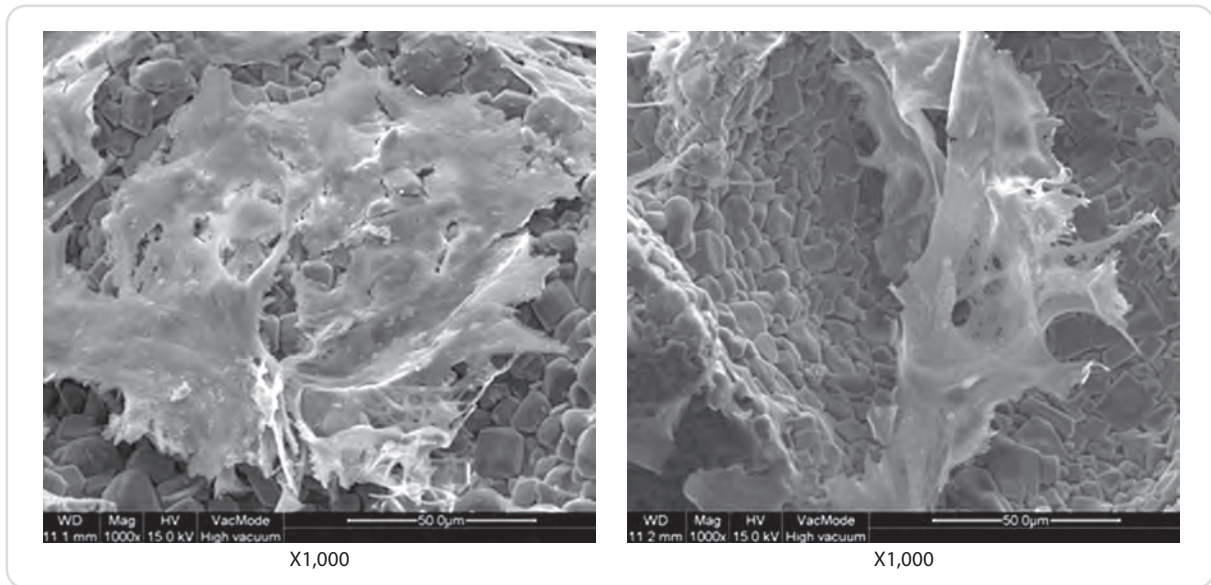

신생골 형성에 적합한 기공율

- > 인체골 상태와 유사한 70%의 다공성 구조
- > 조골세포(Osteoblasts)와 파골세포(Osteoclast) 및 각종 성장인자들의 유입이 용이하여 신생골 형성과정을 촉진

입자표면 SEM사진

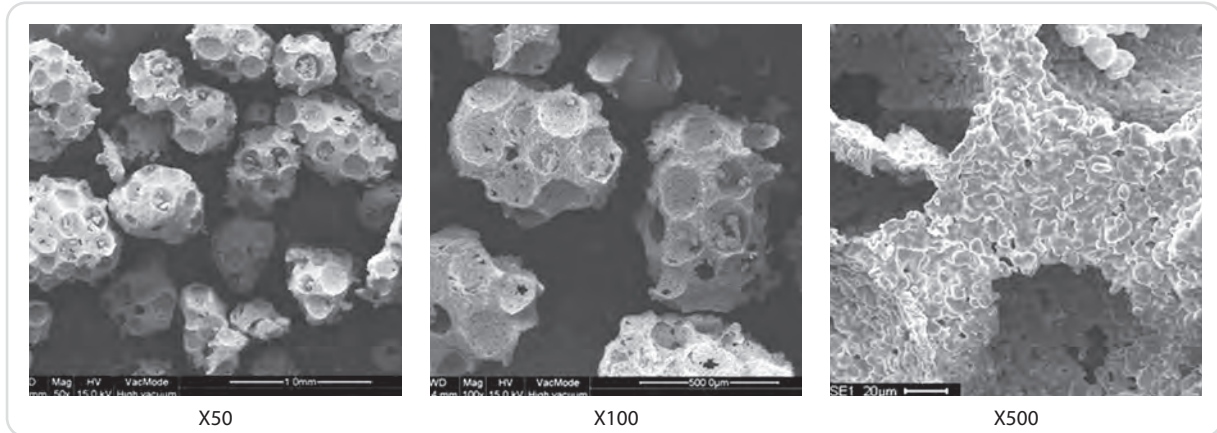

INNO-CaP 적용 범위

1. 상악동 이식술

- > 상악동 이식술 시 단독 또는 다른 이식재와 혼합하여 사용
- > 잔존골 높이(Residual Bone Height : RBH)에 따른 치유기간의 차등

잔존골 높이	1 mm 이하	2 ~ 4 mm	4 mm 이상
임플란트 식립시기	9~12 개월	약 6 months	동시 식립

2. GBR (Guided Bone Regeneration)

- > 자가골 혼합 사용 시 자가골 채취량 최소화
- > GBR 시 단독 또는 다른 골이식재와 혼합하여 사용

제품 용량 및 입자 크기

Product Code	Particle Size	Particle Dose
IG1025	0.4~1.0mm	0.25g
IG1050		0.5g
IG1001		1g
IG1002		2g

임상증례

Case 1

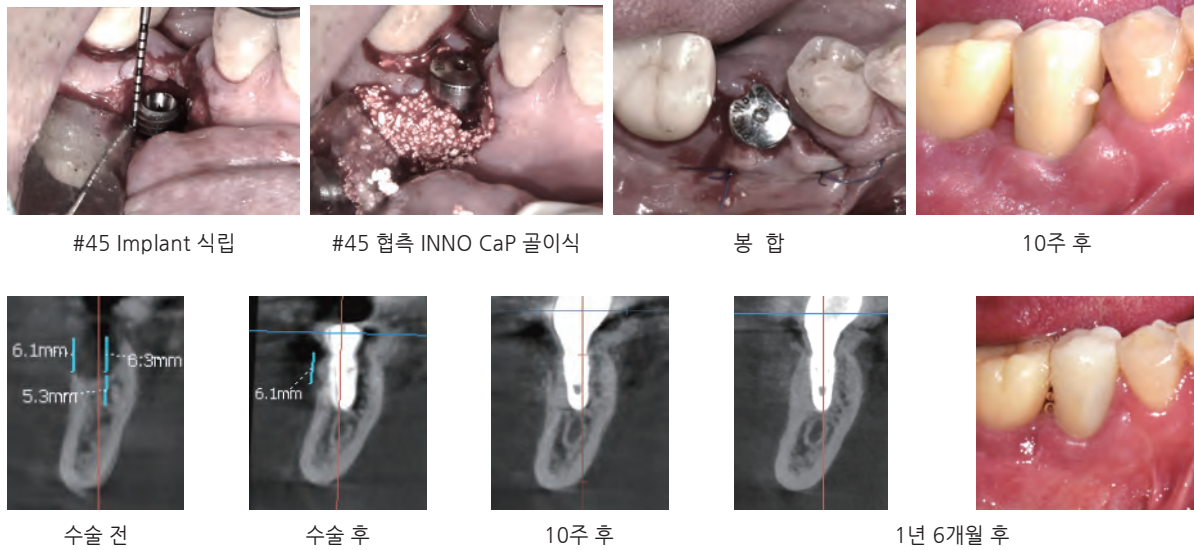

Case 2

INNO-CaP 247

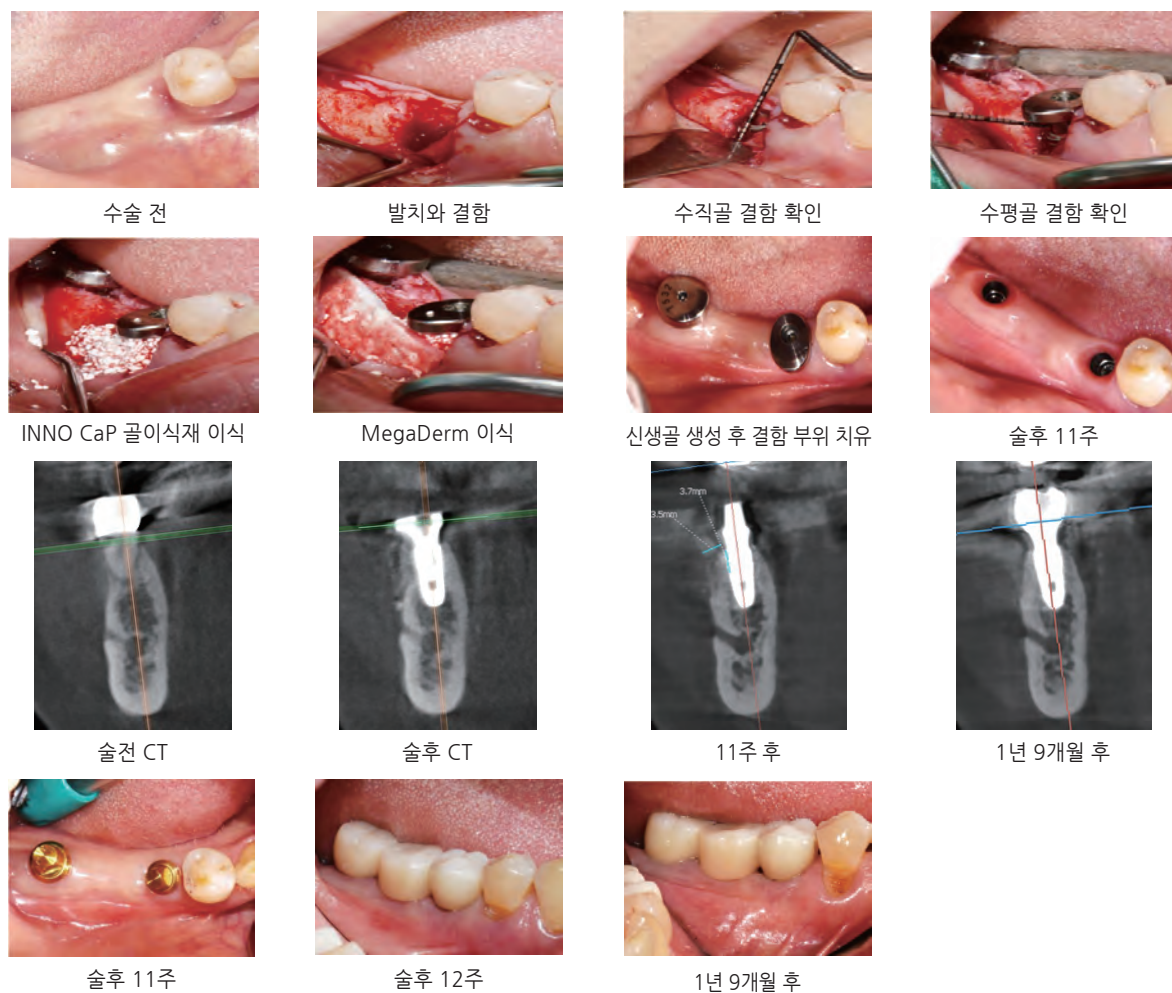

InnoGraft B Predictable GBR Bovine Cancellous Substitute

Bovine Cancellous Bone

01. 인체의 골과 가장 유사한 골이식재

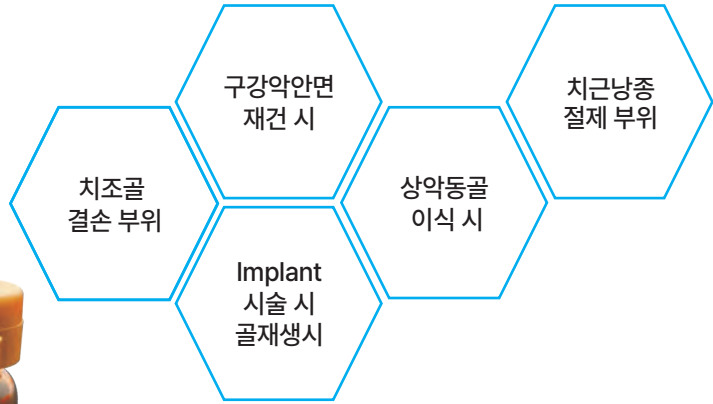

- ✓ 빠른 혈액 침투
- ✓ 초친수성
- ✓ 입체적인 3차원 기공 구조
- ✓ 손쉬운 사용
- ✓ 골 용화 촉진
- ✓ 상호 연결된 다공 구조
- ✓ 최적의 세포 부착 및 혈액 흡수
- ✓ 조골 세포 및 피골 세포의 활동 촉진

02. 인체의 골과 가장 유사한 구조

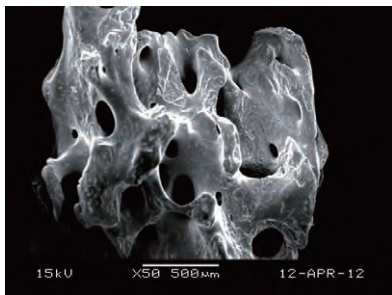

50배 확대

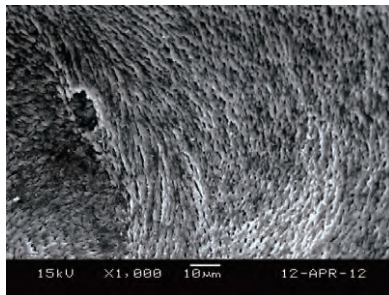

1000배 확대

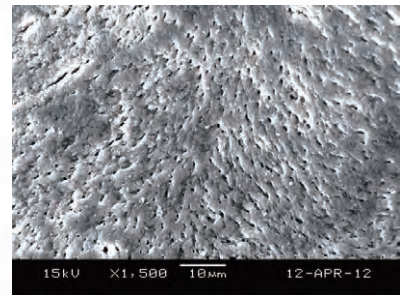

1500배 확대

상호 연결된 다공성 구조는 인간의 뼈와 매우 유사하고 선택적 세포 정착 및 혈액 흡수를 가능하게 할 뿐만 아니라 조골세포와 피골세포의 활동 촉진 가능

03. 초친수성으로 인한 빠르고 완전한 혈액 침투



입체 구조의 초친수성 골 입자들은 안전하고 예측 가능한 결과를 보장하며 골 용화를 촉진시키고 용이한 조작법으로 술자의 만족도 상승

04. 재료의 안전성과 신뢰성

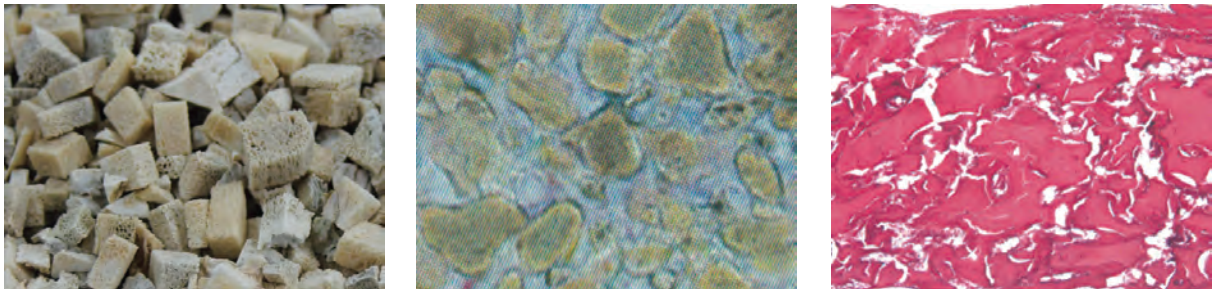

100% 소뼈 해면골 사용

완벽한 유기물 제거를 위한 30여 회 세척 공정

높은 밀도로 견고한 골 형성 (경북대학교 치과재료 시험평가센터)

HA 순도 100% 와 평균 99.73% 골결정화도 (경북대학교 치과재료 시험평가센터)

05. 최적화된 제조 시설과 장비

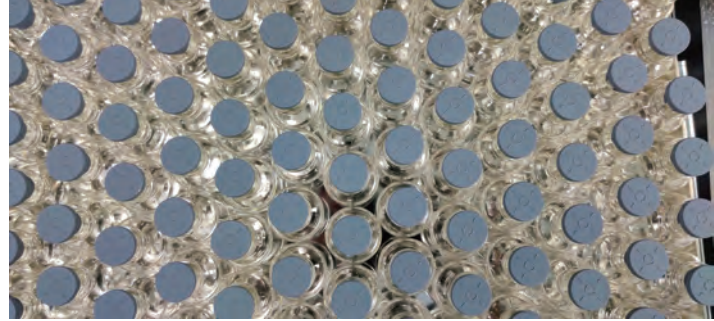
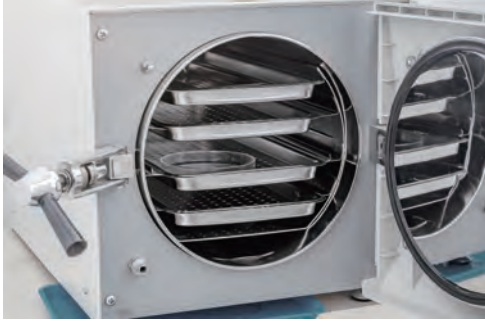

미세한 온도차도 허용하지 않는 초정밀 독일산 Heater (Nabertherm GmbH)
전도력의 필수 요소인 carbon 보존

바이러스 불활성화 공정 (건국대학교 동물생명과학대학)
1000 class 의 높은 수준 클린룸에서 제조

06. 제품 용량 및 입자 크기

M (Medium-sized granules)		
Product code	Granule size	Weight
IGB2015	0.25 - 1.00mm	0.15g
IGB2025	0.25 - 1.00mm	0.25g
IGB2050	0.25 - 1.00mm	0.50g
IGB2100	0.25 - 1.00mm	1.00g
IGB5200	1.00 - 2.00mm	2.00g

Clinical Case I

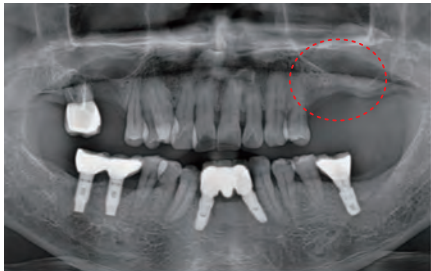

Fig 01. Preoperative radiograph.

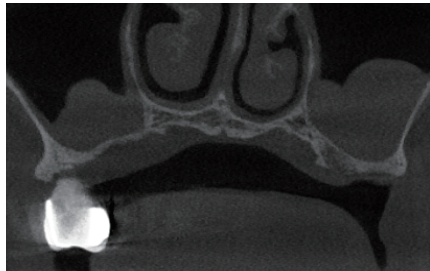

Fig 02. Preoperative CBCT image
Sinusitis in both sinus cavities.

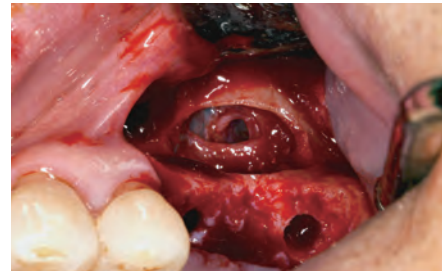

Fig 03. Incision and flap elevation.
Removal of granulation tissue.



Fig 04. Suction of pus from the sinus.

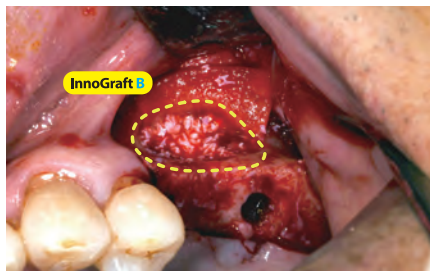

Fig 05. Bone grafting with InnoGraft B.
Resorbable membrane application.



Fig 06. Postoperative radiograph.



Fig 07. Postoperative CBCT image.

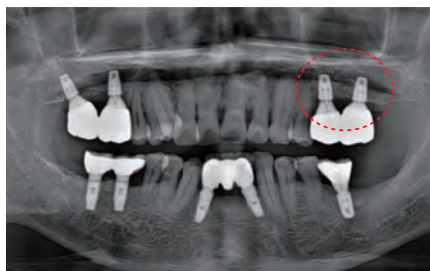

Fig 08. Postoperative radiograph at
6 weeks.
Final restoration delivery.

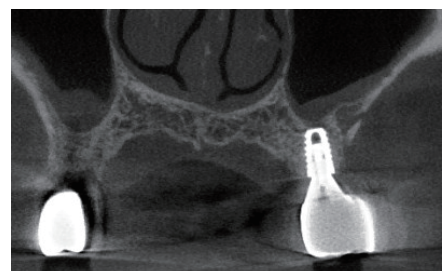

Fig 09. CBCT image of postoperative 10
months.

Clinical Case II

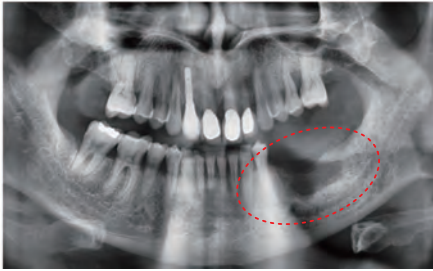

Fig 01. Preoperative radiograph. 3 months after extraction in lower left posterior.

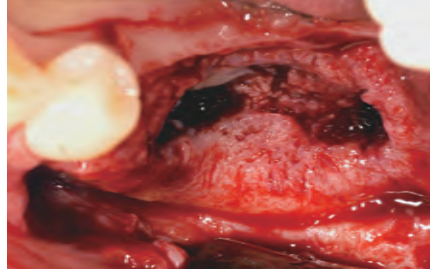

Fig 02. Incision and flap elevation.

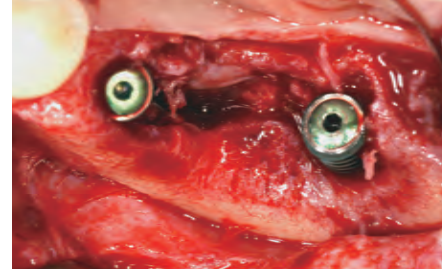

Fig 03. Implant placement on #35, 37.



Fig 04. Bone grafting with InnoGraft B and InnoOss Allo.

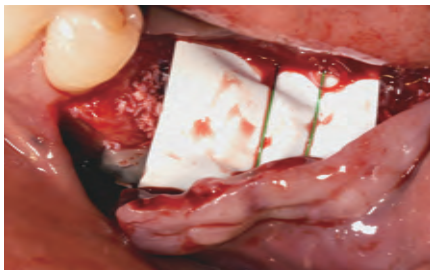

Fig 05. Non-resorbable membrane application.



Fig 06. Sture.

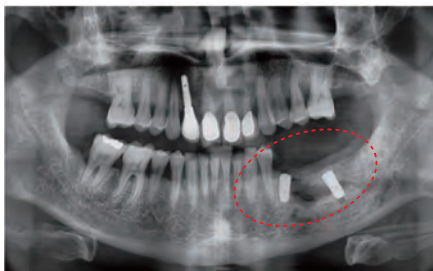

Fig 07. Postoperative radiograph.

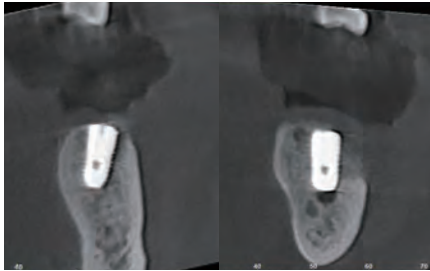

Fig 08. Postoperative CBCT image of #35 (Lt), #37 (Rt).



Fig 09. Clinical view of postoperative 2 weeks.



Fig 10. Clinical view of postoperative 4 months. Final restoration delivery.



Fig 11. Radiograph of postoperative 4 months.

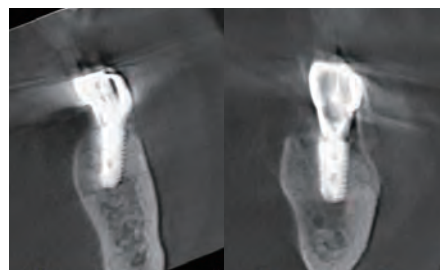

Fig 15. 4 months postoperative CBCT image of #35 (Lt), #37 (Rt).

Clinical Case III



Fig 01. Preoperative radiograph.



Fig 02. Preoperative clinical view.



Fig 03. Extraction and immediate implant placement on #14, #15.

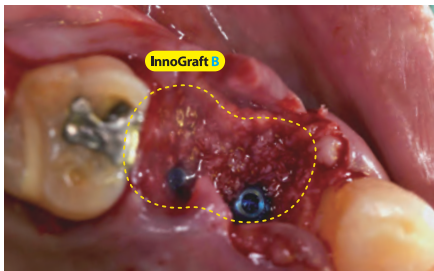

Fig 04. Bone grafting with InnoGraft B.



Fig 05. Suture.

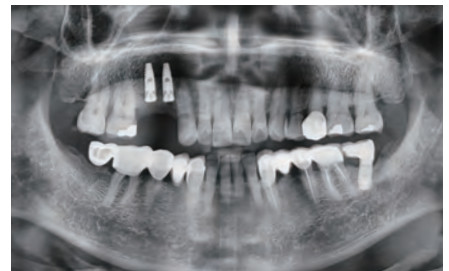

Fig 06. Postoperative radiograph.

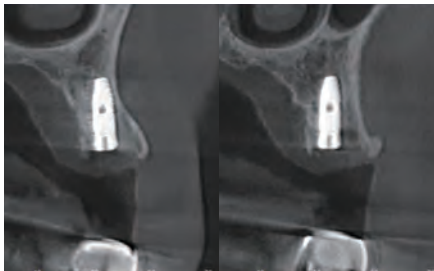

Fig 07. Postoperative CBCT image of #14 (Lt), #15 (Rt).



Fig 08. Clinical view of postoperative 3 months. Abutment connection.



Fig 09. Final restoration delivery.



Fig 10. Radiograph of postoperative 3 months.

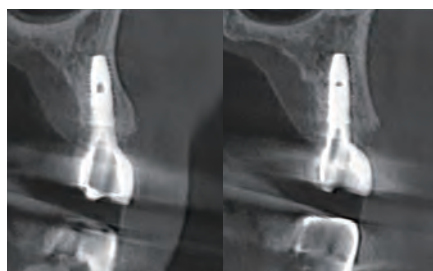

Fig 11. 3 months postoperative CBCT image of #14 (Lt), #15 (Rt).

Clinical Case IV



Fig 01. Preoperative radiograph. Horizontal fracture of #13.

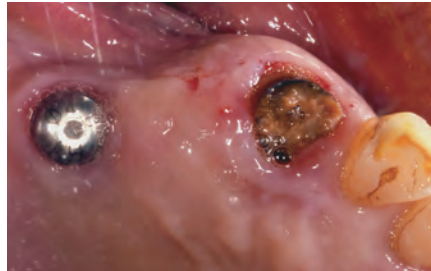

Fig 02. Preoperative clinical view. Old prosthesis removal.

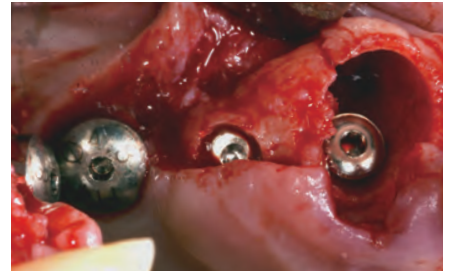

Fig 03. Extraction and immediate implant placement on #13, #14.

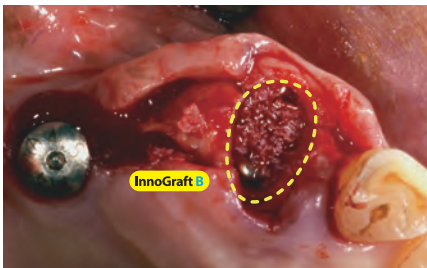

Fig 04. Bone grafting with InnoGraft B.



Fig 05. Postoperative radiograph.

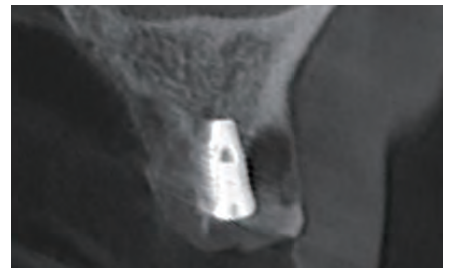

Fig 06. Postoperative CBCT image #13.



Fig 07. Clinical view of postoperative 4 months. Abutment connection.



Fig 08. Final restoration delivery.

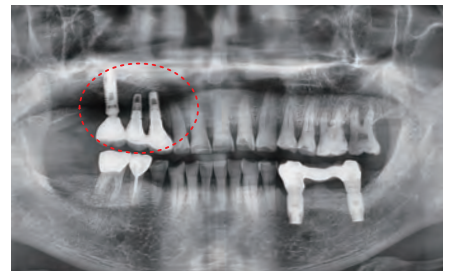

Fig 09. Radiograph of postoperative 4 months.



Fig 10. 4 months postoperative CBCT image of #13.

InnoGenic Wifi-Mesh

보험코드 L7415391

InnoGenic Wifi-Mesh는 흡수성 차폐막을 사용한 경우보다 결과의 예견성이 우수하며 기존 제품의 장점들을 극대화한 비흡수성 차폐막

1. InnoGenic Wifi-Mesh의 장점

- > 세균 독소 침투 차단
 - > 치유 기간 조정
- > 높은 결과의 예견성
 - > Center Hole로 탈부착 용이
- > 우수한 형상 유지 능력
 - > 다양한 사이즈

2. 제품소개

1. 제품구성

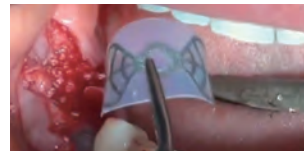

포장단위 : 1개



Product Code	Size	Thickness
BTP1424AA	14X24	0.25
BTP1424AB	14X24	0.25
BTP1525BB	15X25	0.25
BTP1725CA	17X25	0.25
BTP1725CA12	17X25	0.25
BTP2030AB	20X30	0.25
BTP2030AB12	20X30	0.25
BTP2530AB	25X30	0.25
BTP2530AB15	25X30	0.25
BTP3040AB	30X40	0.25
BTP3040AB15	30X40	0.25



BTP1424AA



BTP1424AB

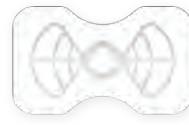

BTP1525BB



BTP1725CA / BTP1725CA12



BTP2030AB / BTP2030AB12

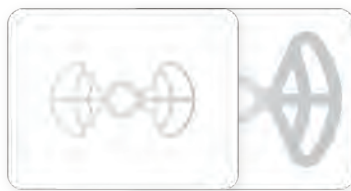



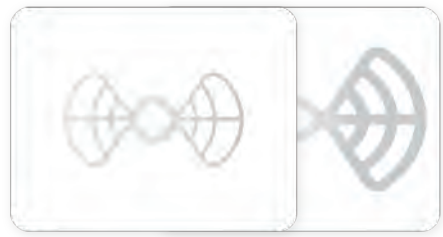







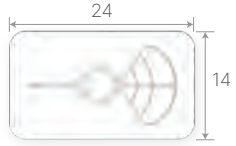

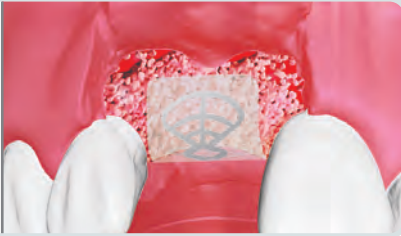
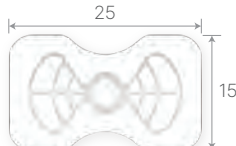
BTP2530AB / BTP2530AB15



BTP3040AB / BTP3040AB15

* 티타늄 재질은 동일

2. 사용방법

 <p>BTP1424AA</p>	<p>협측 또는 설측골 한 측에 결합이 있는 매우 좁은 부위에 적용</p>	
 <p>BTP1424AB</p>	<p>협측과 설측골 양 측에 결합이 있는 매우 좁은 부위에 적용</p>	
 <p>BTP1525BB</p>	<p>치아 간 협측과 설측골 양 측에 결합이 있는 매우 좁은 부위에 적용</p>	
 <p>BTP1725CA / BTP1725CA12</p>	<p>치아 간 협측과 설측골 한 측에 결합이 있는 좁은 부위에 적용</p> <p>* BTP1424AA 호환가능</p>	
 <p>BTP2030AB / BTP2030AB12</p>	<p>협측과 설측골 양 측에 결합이 있는 한 개 치아 이상의 좁은 범위에 적용</p> <p>*BTP1525BB 호환가능</p>	
 <p>BTP2530AB / BTP2530AB15</p>	<p>협측과 설측골 양 측에 결합이 있는 두 개 치아 이상의 넓은 범위에 적용</p>	
 <p>BTP3040AB / BTP3040AB15</p>	<p>협측과 설측골 양 측에 결합이 있는 세 개 치아 이상의 매우 넓은 범위에 적용</p>	

* 사용 및 적용군에 절대적인 디자인은 아니며 포괄적으로 최적화 되어 있음

Fix Connector + Cover Cap를 이용한 적용 방법

GBR Kit - Fix Connector + Cover Cap 사용

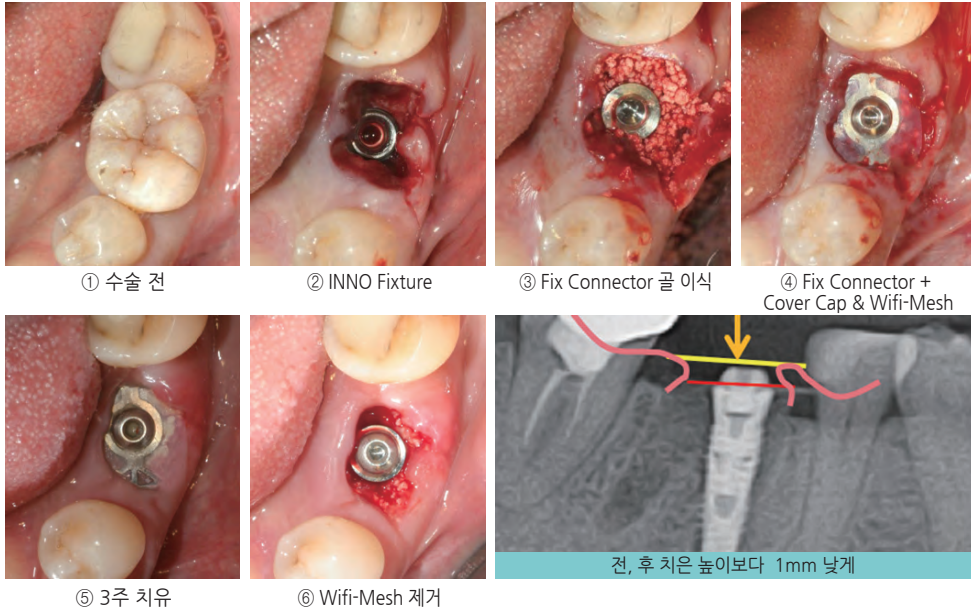





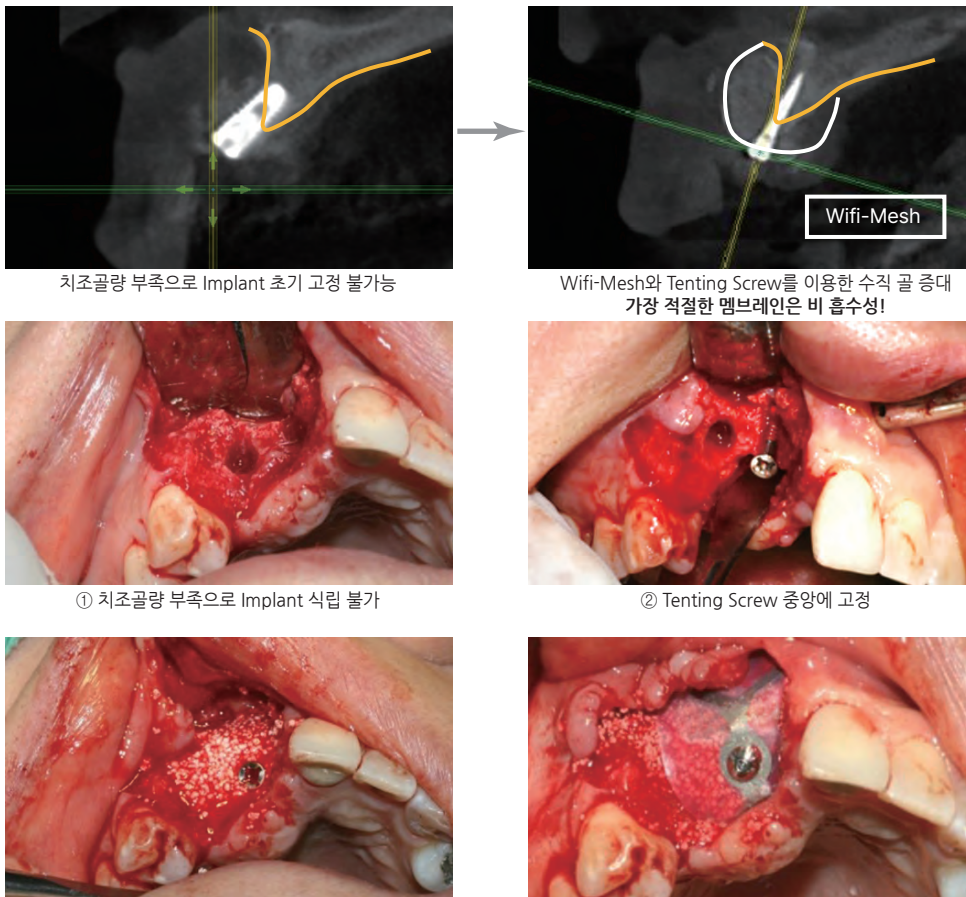





GBR Screw를 이용한 적용 방법

GBR Kit - Tenting Screw, Tenting Cap 사용





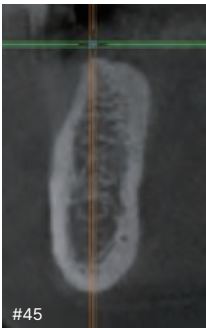

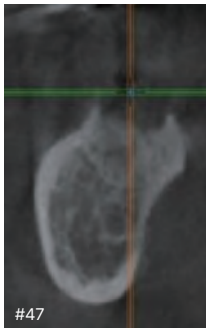
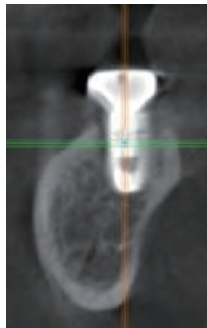



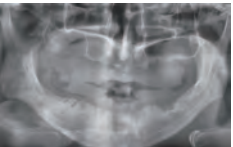

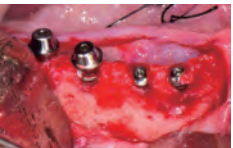

임상증례

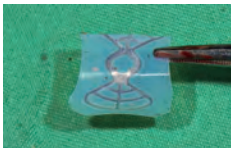
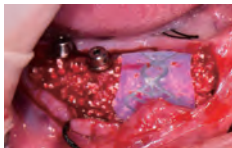
Case 1

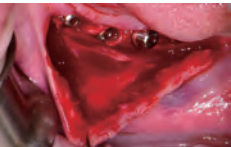
			
수술 전	#45 Implant 식립	#47 Implant 식립	#45 & #46 부위 골 결손
			
#45 협측 골이식	Wifi-Mesh 준비 및 다듬기	#45 & #46 골 결손 부위에 Wifi-Mesh 위치시킴	#46 발치와 부위에 시행한 Open membrane technique
			
#45		#47	

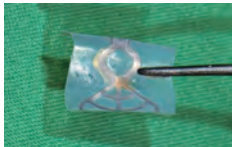
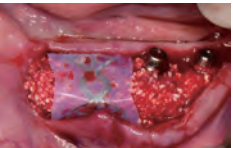
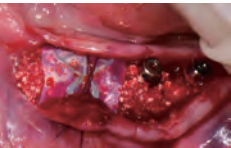
Case 2 Dr. 장호열

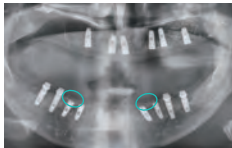
			
수술 전 파노라마	수술 전 구내 사진	판막 거상	식립 부위 천공
			
#43, 44, 45 & 46 Implant 식립	Wifi-Mesh 준비	Wifi-Mesh 형태 형성 *	Wifi-Mesh 장착
			
#33, 34, 35 & 36 Implant 식립	절개(Releasing incision)	골 이식	Wifi-Mesh 준비
			
Wifi-mesh 위치시킴	Membrane holding suture	봉합	수술 후 파노라마

* 확실히 구부러 형태를 형성하여야 하며, 불완전하게 구부릴 경우 치은 안에서 벌어질 수 있습니다.

InnoGenic PTFE-Mesh

보험코드 L7415091

100% 비흡수성 소재로 만들어져 사용자가 치유 기간을 조절할 수 있습니다.

제품 구성 및 사양

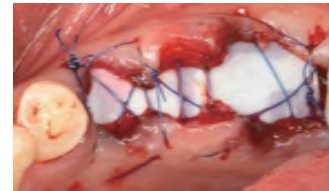
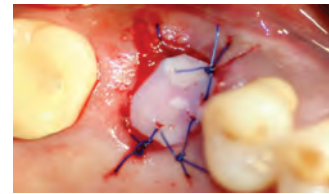
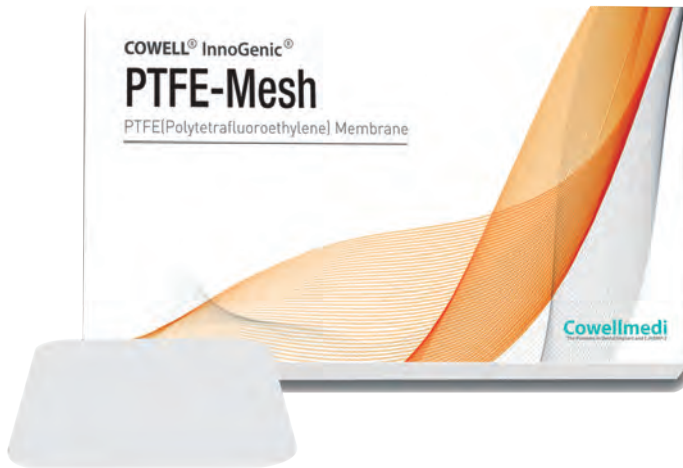

포장단위 : 5개

Product Code	Size	Thickness
TS24301	24 x 30	0.1

제품 특징

- 비흡수성 : 100% 비흡수성 재질로 제작되어 술자가 치유 기간 조절 가능
- 비다공성(0.0 μ m) + 오픈 멤브레인 술식 : 다공성으로 인한 세균의 침투가 불가능하여 감염 또는 결함을 예방하며 오픈 멤브레인 술식도 가능
- 높은 고정력 : 형태를 형성한 뒤 봉합을 하여도 가능 하지만 InnoGenic GBR Kit 구성품을 사용할 시 위치 고정 가능
- 투명한 표면 : 투명한 PTFE 표면을 통해 아래 조직의 치유 과정을 확인할 수 있어 예측 가능성이 높으며 제거 시기 파악 가능
- 형태 유지력 : 결손 부위의 크기와 모양에 맞춰 형성된 형태대로 유지 가능
- 조작 용이 : 비흡수성 재료로 핀셋 등 기본기구를 이용해 쉽게 제거 가능

MEMO

A series of horizontal dashed lines for writing.

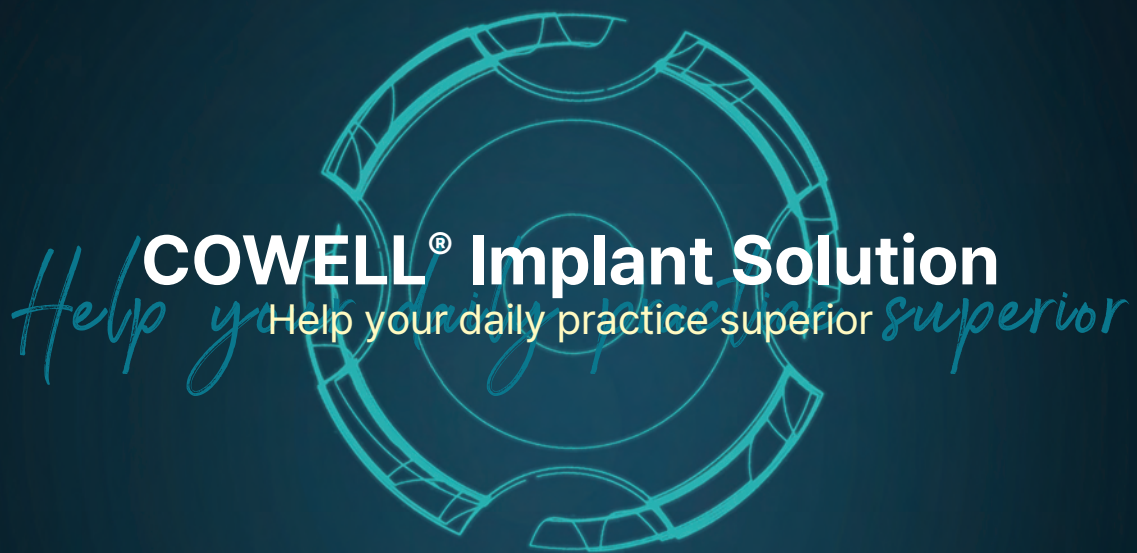

COWELL® Implant Solution

Help your daily practice superior

TOTAL-KOR-250101

Ver.32

www.cowellmedi.com

코웰메디 서울 Head Office

서울특별시 강남구 테헤란로 83길 18, 매직킹덤빌딩 3층

Tel. 02) 3453 - 5085 | Fax. 02) 3453 - 5086 | Email. info@cowellmedi.co.kr

코웰메디 부산 Head Quarter

부산광역시 사상구 학감대로 221번길 48

Tel. 051) 314 - 2028 | Fax. 051) 314 - 2026

Cowellmedi
The Pioneers in Dental Implant and E.rhBMP-2
코웰메디임플란트

